

thermohouse

the complete low energy building system



2024

Revision 11 - April 2024 (Rev.1)

Disclaimer & Guide Details

- All photographs featured in this technical manual showcase projects involving Thermohouse products.
- Section details and reference points provided in this manual are derived from projects conducted by Thermohouse directly or by our customers and installers utilising our products on their sites.
- This manual serves as a guide for using and installing Thermohouse components. While it covers typical scenarios using the “complete low energy building system”, adaptations may be necessary for bespoke elements to suit specific builds as per the design team and end installer's requirements.
- This document is for informational purposes and is a work in progress. Updated editions may be available online in the future.
- The information presented reflects Thermohouse Ltd.'s perspective on discussed issues as of the publication date (1st April 2024). These opinions do not signify a commitment on the part of Thermohouse Ltd. and cannot ensure the accuracy of information post-publication. Users bear the entire risk regarding the accuracy and use of this document.
- This manual complements, but does not replace the fundamental construction knowledge of construction professionals. Structures constructed using the Thermohouse Building System must adhere to all applicable building codes and guidelines provided by a licensed professional engineer. Building code regulations always supersede the instructions in this manual.
- The Thermohouse ICF wall system is a permanent “*SHUTTERING KIT*”, It should be treated as such and provided with adequate support, propping and alignment to maintain the concrete it is to be filled with.
- An accurate wall layout is critical to ensure a satisfactory outcome. Prior to laying the first course of blocks it is recommended that the Thermohouse layout is rechecked again for accuracy and that it is set out in measurements with increments of 150mm this will apply to the majority of the measures except in certain instances.
- The Thermohouse Forms are 1200mm long,350mm wide & 250mm course height. Double check the **Thermohouse set-out** for the project. This **IS** your building set-out guide.

Table of Contents

Introduction & General information	13
What is the Thermohouse Complete system?	13
Site Safety	14
Toxicity:.....	14
Waste Disposal:	14
Expanded Polystyrene (EPS)	15
Building Regs & Thermohouse.....	16
Air Tightness:.....	16
U-Values:	16
CO2 Emissions:.....	16
System Overview:.....	16
Required Tools, Materials & Accessories	17
Requesting a quote.....	18
Thermohouse Details Index	21
Delivery, Handling & Storage Guide	22
Before the Delivery.....	22
Site Restrictions	23
Delivery Day.....	23
Offloading & Handling.....	24
Storage.....	25
Charges	27
Damages	27
Contact form.....	27
Design Guidelines	30
Wall System	33
Wall Elements	36
Retaining Walls	36
External walls	36
Internal Walls.....	36
Wall Block Range	37 - 50
350mm Standard Retaining Wall Block	37
350mm Standard Retaining Wall Block Family.....	38
400mm Passive Retaining Wall Block.....	39
400mm Passive Retaining Wall Block Family	40
300mm External wall block	41
300mm External wall block family	42
350mm External wall block	43
350mm External block family.....	44

450mm External wall block	45
450mm External wall block family	46
250mm Internal load bearing wall block	47
300mm Party wall block.....	48
Independent wall components	49
Essential installation components	51
Basement Construction	52
Basement Construction Checklist	53
Typical Basement detail	54
Single Storey Basements.....	56
Multi-Story Basements.....	57
Basement Wall Construction Guidelines.....	59
Accurate Footings & Slabs.....	61
Standard Wall Construction Overview	64
Wall Layout.....	67
Party walls & Firestopping	78
Wall Alignment System / Propping System Guide.....	87
Reinforcement	96
Windows & Doors.....	100
Window & Window Cill Installation	102
Guideline and Procedure for Window Cill DPC	106
Extensions	108
Services Penetrations.....	110
Concrete Placement	111
Pre-pour Checklist	113
Post-pour Checklist.....	114
Wall Plate Connections.....	115
Electrical Installation.....	117
Plumbing Installations	118
Thermowall Finishes.....	119
Thermowall Internal Finishes	119
Thermowall External Finishes.....	123
Render Finish.....	124
Natural Stone & Brick Finish	125
Brick Slip / Stone Slip & Tile Finish	129
External Baton & Cladding Finish	131

Flooring Systems 134

Concrete flooring systems.....	135
Thermofloor.....	135
Thermofloor Elements.....	136
Thermofloor Ground Floor.....	139
Thermofloor Intermediate Floors	142
Thermofloor – Build Ups	147
Other solutions using Thermofloor	151
Thermofloor Acoustics	152
Pre-Cast Floors (Hollowcore)	152
Block & Beam.....	154
Composite Metal Deck Flooring.....	156
Suspended Timber Floor	158
Metal Ledger fixings	161
Thermofloor – As a flat roof	162
Services Under Intermediate Floor Slab	1644
Electrical Installation	165
MVHR Ducting / Plumbing & other services	165

ThermorooF Elements 169

ThermorooF Application.....	172
ThermorooF Design	172
Tools Materials & Accessory requirements	175
Delivery, Storage & Marking.....	176
Wall Plate.....	177
Panel Fixing Screw	180
Ridge, Hip & Valley Connections	181
Ridge Straps.....	181
Purlin Supports	184
ThermorooF Partywall.....	188
ThermorooF Air-tighness & Sealing	190
Roof Windows	192
Battens & Vapour Membrane	196
Underlay, Slating & Tiling	197
Chimney	199
Facia & Soffit / Eaves Detailing.....	201
Gable Ends.....	207
Collar Ladder Bracing	210
Roof Finishes	212
External Finishes	212

Lead Flashing.....	214
Internal Finishes.....	215
Zinc	218
Solar Panels	219
Openings & Services.....	220
General Provisions	221
ThermorooF as a Flatroof	222
Thermoboard – For Underfloor Heating Pipes	226
Thermoboard Elements	227
Thermoboard Installation Steps	230

Annex's

Annex 1	232
300mm Thermowall Psi Values	
Annex 2	233
350mm Thermowall Psi Values	
Annex 3	234
Thermowall 450mm Psi Values	
Annex 4	236
BRE Acoustic Testing – Airbourne.....	
Annex 5	237
BRE Acoustic Testing – Impact.....	
Annex 6	238
Air Permiability Testing – Sample report (completed Project)	
Annex 7	239
Energy Performance Certificate – Sample report (completed project)	
Annex 8	240
.....	
Annex 9	241
NSAI Agreement Thermohouse ICF System Certification	
Annex 10	242
NSAI Agreement Thermohouse Roofing System Certification.....	
Annex 11	243
BHRC Certification	
Annex 12	244
BRE Thermorooof Load Testing.....	
Annex 13	245
210mm Thermofloor element with Inserts thermal performance.....	
Annex 14	247
BRE Thermowall & Thermorooof – Thermal Testing	
Annex 15	248
BRE Suspended Thermofloor & Flat Roof – Thermal Testing.....	
Annex 16	249
BRE Thermofloor as a Flatroooof – Intersitual Condensation Report.....	

Annex 17	252
Seismic Test Certification.....	
Annex 18	253
Thermohouse UAE System Certification	
Annex 19	254
Reaction to Fire report	
Annex 20	255
Reaction to Fire report	
Annex 21	256
Council of Mortgage Lenders letter.....	
Annex 22	257
BBA Letter	
Annex 23	259
Roof CE Mark & DOP	
Annex 24	260
160 Floor CE Mark & DOP	
Annex 25	261
210 Floor CE Mark & DOP	
Annex 26	262
250 internal LB Walls CE Mark & DOP	
Annex 27	263
300 External Walls CE Mark & DOP	
Annex 28	264
300 Internal LB Walls CE Mark & DOP	
Annex 29	265
350 External Walls CE Mark & DOP	
Annex 30	266
Pre-pour Checklist.....	
Annex 31	267
Post-pour Checklist	
Annex 32	268
Invoice & Delivery Information	
Annex 33	269
Technical Details Register	Also page 9

Technical Manual Diagram Reference

Manual			TH Ref
Diagram Ref	Page	Description	Dwg.No.
G1	30	Design Guidelines	
F1	54	Re-inforcement + INT & Ext Tanking Detail	
F2	55	Basement Raft Foundation Detail	TH-002
F3	61	Strip Foundation Detail	TH-001
F4	62	Raft Foundation Detail	TH-002a
F5	62	Raft Foundation with Perimeter Insulation	
F6	60	Basement wall Corner Assembly	
W1	71	End Block Corner Assembly - Standard Corner	TH-023
W2	78	300mm Party Wall to External Wall Detail with Brick Skin	
W3	79	Firestopping on Party Wall Detail	TH-017
W4	78	300mm Party Wall to External Wall Detail (ICF)	
W5	68	Internal Load Bearing Wall Abutting to External Wall	TH-024
W6	69	Party Wall Abutting to External Wall	TH-026
W7	70	Internal Block Wall Abutting External ICF Wall	TH-025
W8	80	Typical Horizontal Fire Stop at Floor Level Detail	TH-017b
W9	108	Abutment to Existing Build	
W10	104	PPC Aluminium Window Cill	TH-011
W11	120	(Steel) Thermowall Fixing Plates	TH-017L
W12	97	Reinforcing Steel Design	TH-016
W13	55	Ext Wall Build up above 350mm Basement Block	THF-003b
W14	70	Internal Load Bearing Wall Abutting to External ICF Wall	TH-025b
W15	94	3.0m Wall Support & Scaffold Support	
W15b	95	3.0m Corner Wall Support	
W16	71	End Block Corner Assemble - Inverted Corner	
W17	103	Concrete Window Cill	TH-010
W18	105	Section Through Door Opening	TH-014
W19	74	Window Head	
W20	105	Window Head	TH-012 Fig 19
W21	102	(Plan View) Rebate Block at Window/Door Opening	TH-013 fig 3
W21	74	Window Reveal Detail	TH-013 fig 3
W22	102	Reveal Section - Flush Mounted Window	
W23	126	Thermowall Finished with Stone or Brick	TH-028c
W24	128	Thermowall Finished with Brick Slip	TH-028d
W25	130	Thermowall Finished with Cadding	TH-018e
W26	72	90 Deg Internal Corner Assembly	
W27	77	Connecting Traditional Block Walls to ICF Junctions	
W28	119	Wallboard fixed to Thermowall	TH-018a
W29	119	Wallboard fixed to Batten on Thermowall	TH-018
W30	79	Firestop Detail	
W31	116	Wall Plate for Thermorroof Detail	

TF1	138	Suspended G/F Thermofloor Detail (U-Value 0.16)	THF-002
TF2	139/142	Placement of TH21 External Leaf with Floor Panel	
TF3	139	Edge Support to TH21 at Floor Edge (Photo)	
TF4	141	Intermediate Thermofloor Build Up	
TF5	142	Intermediate Thermofloor	
TF6	143	Thermofloor Propping Support	
TF7	144	Thermofloor Propping Support (Photo)	
TF8	144	Acrow Placements - Step 1	THF-004
TF9	145	Acrow Placements - Step 2	THF-005
TF10	1465	Acrow Placements - Step 3	THF-006
TF11	146	Concrete Area Coverage	
TF12a	150	Cantilever Floor	
TF12b	150	In-situ Floor Beam	
TF13	151	Pre-Cast Floor on External Wall	TH-003
TF14	152	Pre-Cast Floor on Internal Wall	TH-005
TF15	153	Block & Beam on Thermowall	TH-001c
TF16	154	Block & Beam on Brick Wall	TH-001d
TF17	156	Metal Deck Floor	TH-006
TF18a	158	Timber Joist Fixing - Option 1	TH-007
TF18b	158	Timber Joist Fixing - Option 2	
TF18c	159	Timber Joist Fixing - Option 3	
TF18d	159	Timber Joist Fixing - Option 4	TH-007
TF19	161	Metal Ledger System Detail	TH-008
TF20a	162	Thermofloor 210mm Flat Roof (Open Edge)	THF-010
TF20b	162	Thermofloor 210mm Flat Roof (Parapet)	THF-010
TF20c	163	Thermofloor Flat Roof Section	THF-010
TF21	147	160mm Suspended Floor Build Up	
TF22	147	210mm Suspended Floor Build Up	
TR1	168	Thermoroof Element	THR-001
TR2	169	Thermoroof Element Dimensions	THR-002
TR3	174	Beval Cut Detail	THR-003
TR4	177	Thermoroof to Thermowall	
TR5	178	Thermoroof to Thermowall 350mm	THR-008a
TR6	179	Timber Cut or Truss Roof to Thermowall	
TR7	180	Thermoroof to Brick/Block Wall	THR-008c
TR8	181	Thermoroof Ridge on Steel Detail	THR-010a
TR9	182	Thermoroof Fixing Detail	THR-010a
TR10	182	Thermoroof on Timber Ridge Detail	THR-010b
TR11	183	Thermoroof Valley Detail	
TR12	185	Thermoroof Purlin (Timber on Steel Beam)	THR-004a
TR13	185	Thermoroof Purlin (Timber on Steel Beam) Through section	THR-004a
TR14	186	Thermoroof Timber Purlin	THR-0043b
TR15	186	Thermoroof Timber Purlin (through Section)	THR-0043b
TR16	187	Thermoroof Concealed Purlin	
TR17	188	Thermoroof & Thermowall Party Wall Firestop	THR-017
TR18	190	Thermoroof Airtightness Sealing	
TR19			

TR20	192	Thermorooft Rooflight Detail	THR-13a
TR21	195	Dormer Windows	THR-018
TR22	197	Roof Batten Fixing	THR-005
TR23	198	Roof Batten & Underlay Fixing	THR-007
TR24	200	Chimney Stack Cross Section	THR-011
TR25	201	Angled End Thermorooft Detail	THR-008
TR26	202	Straight End Thermorooft Detail	
TR27	204	Wallplate Shoe Overhang Section	THR-008b1
TR28	205	Flush Facia	THR-008c
TR29a	207	Gable End / Timber Ladder (Option A)	Photo
TR29b	208	Gable End / Timber Ladder (Option B)	THR-015a
TR29c	209	Gable End / Timber Ladder (Option C)	THR-015b
TR31	211	Fabrication of Collar Ladder	
TR32	214	Lead Flashing	THR-012
TR33	215	Plasterboard Fixing on Batten to Thermorooft	THR-009a
TR34	217	Rendered Finish to Thermorooft	THR-009b
TR35	218	Zinc Type Roof Finish	THR-022
TR36	222	Thermorooft Flat Roof with Overhang	THR-016
TR37	223	Thermorooft Flat Roof with Parapet Wall	THR-016a
TR38	224	Thermorooft Lean-to Roof	THR-014
TB1	229	30mm Free Flow Thermoscreed	
TB2	229	75mm Concrete Screed	



Introduction & General information

What is the Thermohouse Complete system?

The Thermohouse modular building system comprises the following essential components:

- Insulating Concrete Formwork (ICF) Walls
- Energy-efficient intermediate flooring system
- Energy-efficient roof system
- Energy-efficient ground floor insulation

Manufactured to the most rigorous standards, Conforms to EN in the market, the Thermohouse complete low-energy building system is certified for construction up to six stories in height. Since 2008, this system has been consistently delivering high-quality homes across Europe. Accredited by the Irish Agreement Board (IAB), the Thermohouse system is synonymous with reliability.

Crafted in a state-of-the-art facility situated in Killarney, Co Kerry, Ireland, the Thermohouse “complete low-energy building system” ensures swift delivery, exceptional service, and comprehensive customer support throughout Europe. Our proficient technical team is always on standby to address any inquiries and provide practical guidance for the efficient installation of the system.

Installation can be performed either by Thermohouse directly or by certified installers. Detailed technical information is available in the following certifications:

- Irish Agreement Board – 08/0310
- Irish Agreement Board – 10/0349
- BRE - ThermoRoof & Wall Thermal Testing
- BRE - ThermoFloor Thermal Testing
- BRE - Flat Roof & Suspended Floor Thermal Testing
- BRE - Flat Roof Interstitial Condensation Risk Analysis
- BRE - Acoustic Testing – Airborne & Impact

Please note:

The advice presented in this publication is based on the most authoritative information available. Users are responsible for ensuring its relevance to their specific circumstances. When in doubt, seek professional guidance. All certifications mentioned in this document were current at the time of printing. All rights reserved. Reproduction, storage in a retrieval system, or transmission of any part of this publication is prohibited without prior consent from the publishers.

For clarifications or additional technical support, please contact us at +353 (0)64 663 1307.

Site Safety

Within the framework of the Safety, Health and Welfare at Work Regulations, the responsibility falls upon the site manager to ensure strict adherence to pertinent health and safety regulations throughout the construction process. These encompass, though are not confined to, the following measures:

When working with concrete, protective clothing and eye protection are imperative to safeguard against potential cement burns and dust inhalation. Engaging with power tools mandates the use of personal protective equipment like hard hats, gloves, ear defenders, and eye protection. Situations involving work at elevated levels, particularly on scaffolding in conjunction with Thermohouse system alignment/propping frames, necessitate meticulous consideration of the applicable regulations. Handling of materials manually—such as blocks, flooring, and roofing panels—requires careful attention to prevent injury.

Fire safety is paramount; Thermohouse components are constructed from flame-retardant polystyrene, yet exposure to flames or solvents can result in melting. Roof and flooring panels contain galvanized steel "C" sections within their structures and wearing suitable personal protective equipment (PPE) is mandatory to avert harm.

Toxicity:

Under normal circumstances, the system poses no toxicity risk. In the event of a fire, the polystyrene will gradually soften, contract, and ultimately melt above temperatures of 100°C. Ignition occurs between 350°C and 450°C. The quantity of material present is minimal; hence the released heat is limited. In combustion, expanded polystyrene (EPS) behaves similarly to other hydrocarbons like wood and paper. The byproducts of combustion mainly include carbon monoxide and styrene. During a fire, styrene might undergo further decomposition, releasing carbon oxides, water, and a certain amount of smoke. The polystyrene utilized in ALL Thermohouse products is flame-retardant.

Waste Disposal:

The wall forms, roofing, and flooring panels are constructed from high-density EPS. It is imperative to adhere fully to local authority regulations when disposing of any waste material.

An HSDS data sheet can be obtained upon request.

These notes serve as a guideline to highlight certain aspects concerning site safety. They are by no means exhaustive. For additional information, please reach out to the relevant Health and Safety Authority.

Expanded Polystyrene (EPS)

Expanded Polystyrene (EPS) consists of 98% air and 2% polystyrene, offering a minimum lifespan of 60 years. Remarkably, EPS requires less than 0.1% of the global oil supply as a raw material, leading to potential thermal energy savings equivalent to 200 times its own resource. This energy efficiency is exemplified in the EPS thermal insulation's energy payback. When applied in the thermal renovation of a house, the primary energy utilized in EPS production is recuperated within an impressive 2 to 4 months.

For applications in commercial construction, EPS achieves the highest attainable A-plus summary rating in the BRE Global Green Guide to specification. Furthermore, EPS earns 'A' ratings across the majority of critical environmental performance metrics, encompassing:

Water Extraction: A+
Mineral Resource: A+
Stratospheric Ozone Depletion: A+
Human Toxicity: A+
Ecotoxicity: A+
Nuclear Waste: A+
Waste Disposal: A+
Fossil Fuel Depletion: A
Eutrophication: A+
Acidification: A

EPS exhibits both lightweight and low-impact qualities, coupled with its impressive insulation properties that yield substantial energy savings. Notably, approximately 85% of a building's environmental impact pertains to energy consumption during its occupation phase, primarily driven by heating and cooling requirements. Therefore, the key environmental aspect of any insulation material lies in its sustained thermal performance throughout the building's lifespan, alongside design considerations aimed at preserving this thermal efficiency.

It's crucial that insulation materials possess enduring properties, such as:

Consistent Thermal Insulation Value
Low Moisture Absorption
Mechanical Strength (to counteract wear and tear over the building's lifespan)
Resistance to Rot, Mould, and Decay
Resistance to Rodent Infestation

Keep in mind that precautions should be taken to prevent UV damage to EPS products.

Building Regs & Thermohouse

Building regulation requirements may differ between the Republic of Ireland and the UK. However, this system exhibits the flexibility to meet and often surpass the demands of both countries. It is adept at achieving compliance with Building Regulations, Nzeb standards (nearly zero energy buildings), Passivhaus standards, and the Future Homes Standard.

Air Tightness:

The system boasts one of the highest levels of airtightness achievable. It can attain an air tightness rating of less than $1\text{ m}^3/(\text{hr.m}^2)$ or better @ 50 Pa when utilized as a complete system. Additionally, all window and door frames are fixed to rebated wall forms, effectively minimizing heat loss due to draughts.

U-Values:

The system surpasses the requirements of minimum standard U-Values and is capable of achieving suggested U-Values with enhancements. It not only outperforms traditional methods but does so with remarkable ease.

CO2 Emissions:

The production of this low energy building significantly enhances end-user CO2 emissions over the life of the structure. The Insulating Concrete Form (ICF) used is an environmentally friendly building product. The design's exceptional airtightness renders it exceptionally suitable for integrating renewable energy systems. Reduced construction time results in lower CO2 emissions during the building process. Moreover, the decrease in supplementary or traditional products further reduces CO2 emissions during construction.

System Overview:

This system is classified as a Modern Method of Construction (MMC). It effectively eliminates the risk of cold bridging. It empowers the realisation of a designed and built structure without compromising on performance. The risk of sub-par workmanship, shortcuts, and compromises in performance is eliminated. Notably, there's no allowance for substitution of products during the construction phase that could compromise performance.

Required Tools, Materials & Accessories

- Wall alignment / bracing system
- Scaffold planks
- Safety Rails
- Gloves
- Hand saw
- Tin Shears (Aviator)
- Tape measure
- Cordless drill
- Hammer drill
- Impact drill
- Hammer
- Spirit Level
- Plumb bob
- String line
- Foam gun
- Concrete vibrator poker (37mm)
- Hot knife / Router

The site manager and installer must adhere to the manufacturer's instructions for proper handling, usage, and storage of any items mentioned in the list above.

Requesting a quote

Before requesting a quote, it's essential to follow these steps and review the process flow chart to grasp the journey from initial stages to site delivery. This sample outlines a typical journey, but any site-specific aspects will be communicated accordingly.

A detailed quote will only be prepared upon obtaining full planning permission. If planning permission is not granted, we may consider offering lump sum costing after reviewing the provided information.

To ensure a prompt and comprehensive quote, please include the following detailed information when submitting an inquiry:

- Your Full Name
- Final Invoice Recipient Name
- Contact Phone Number
- Email Address
- Project Delivery Address
- Offloading Address (if different from the site)
- Is planning approval obtained?
- Is an Architect appointed?
- Is a Structural Engineer appointed?
- Approximate on-site start date
- Which key components of the Thermohouse system are you seeking?
- Do you have a builder ready for system installation?

The Thermohouse Journey

The process flow chart illustrates the general path from the initial stages to site delivery. While this sample provides a typical journey, it's crucial to highlight that we tailor our approach to each project's unique requirements.

Our expertise and adaptability enable us to handle projects ranging from single-unit houses to multiple housing schemes, allowing us to adjust the journey to align with the specific needs of each site. This flexibility allows us to coordinate materials, payments, and deliveries to suit any scheme.

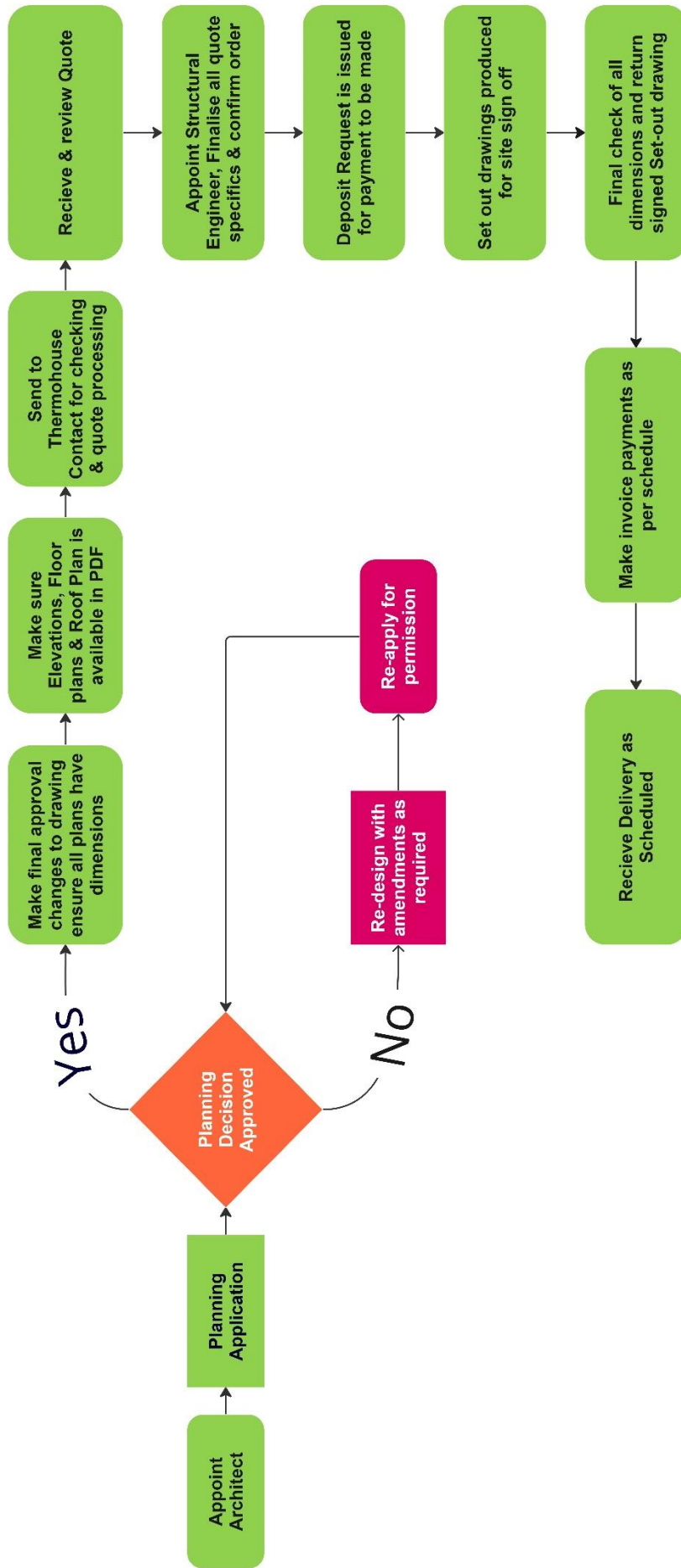



Thermohouse Details Index

The manual displays essential section details, but it's not restricted to these alone. Additional section details, outlining alternative options for custom projects, are also included.

If your design involves unique elements needing our support, don't hesitate to consult our technical team for further assistance.

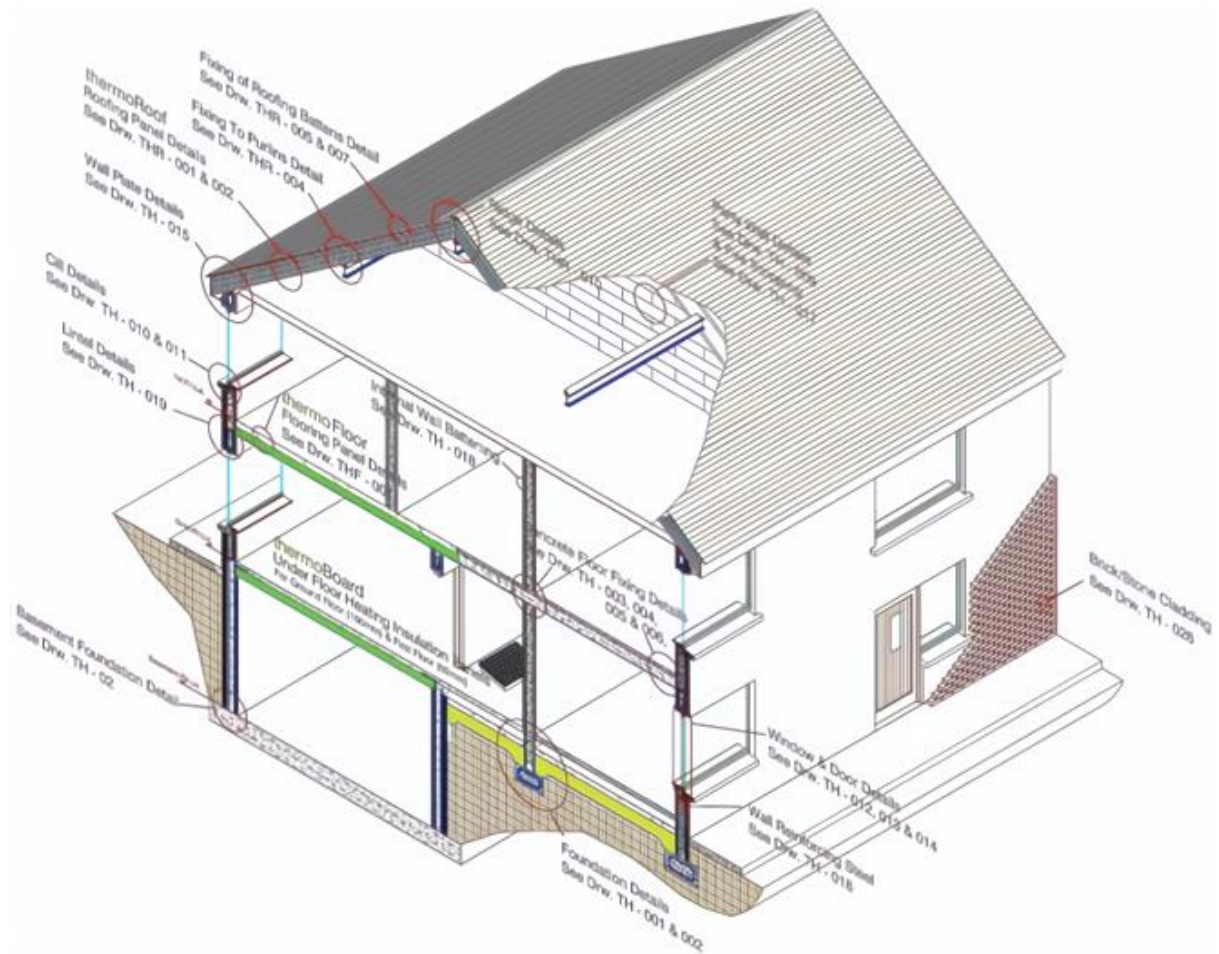

Delivery, Handling & Storage Guide

Before the Delivery

Thermohouse supplies products across the republic of Ireland & UK. All deliveries are carried out by our own transport within the republic of Ireland, or by selected haulers across the UK.

Upon confirming to place the order with Thermohouse for your materials we will require the Site Information Form to be completed with all the information for the delivery to take place without any delay or misunderstandings. We will send you this form prior to deposit payment.

Thermohouse or one of our delivery partners will contact the client based on the information provided on the Site Information form.

Deliveries of all materials will take place directly from our manufacturing facility in Ireland. This will be from: -

Thermohouse Ire. Ltd
Coolcaslagh
Killarney
Co.Kerry
V93 XK82

All deliveries are sent out on Articulated "High Cube" Curtain sided units approx. 51ft long X 7ft wide X 15.5ft high.

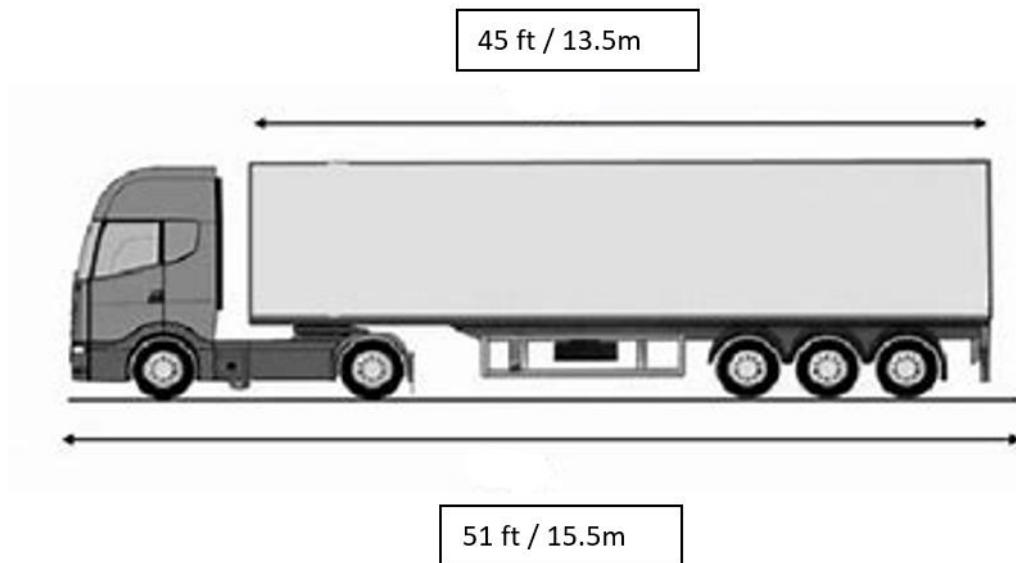

Pre Order checklist:

- Has the site information form been completed and sent.
- Can the access road accept this type of articulated unit.
- Is there space on or off the site to unload the trailer.
- Is there space for the articulated unit to turn.
- Will there be enough space for a mechanical loader to offload.
- Is the storage area easy to reach from trailer.

Up to 48 hours before the delivery day, Thermohouse or our Transport Carrier making the delivery will contact the person named on the Site Information Form to confirm date and time with you.

Site Restrictions

If your site cannot take the articulated unit, or there are access restrictions on route, you must let us know before placing the order, so we can either look at alternative options which may include smaller units, alternative delivery address, collection from the factory etc. All of these will have an impact on the final price, so we need to know early.

Delivery Day

On the date of the delivery the driver will arrive as arranged. Site must be prepared to offload the material and store it in a suitable location. Offloading materials should be with mechanical methods only.

The trailers will be loaded with the materials required for your specific project. The material on the trailer will be dependent on the specification, and usually packed in full as below image.



The Thermowall blocks are packed in bales of 18 & 15 (ext, wall) or 24 & 20 (Int. wall) to utilise the full height on the trailer. The depth of the bails will depend on the block type. A typical trailer will carry between 48-52 of mixed bales.

The floor panels will be loaded individually and will not be banded. This is to avoid damage to the floor panel edges which are easily damaged if not handled correctly. These are generally offloaded by hand onto a forklift, please ensure that the panels are lifted by the service holes on either end **not by the edges.**



Roof panels will be delivered banded in large bails of 10 – 12 panels and must be offloaded by forklift.



Offloading & Handling

The safest method to offload is using mechanical methods like a telehandler or forklift.



All floor and roof panels must be offloaded using forklifts only, this will avoid damage and reduce any safety risks onsite whilst unloading as the products are very bulky and not so easy to man handle off the trailer.

This will also avoid the risk of any panels being dropped off the trailer. It is for the site manager to supervise and assess any risks from the offloading of materials from the trailers.

The blocks can be offloaded by inserting the forks into the space between the steel bridges as marked below, or by tilting the packs slightly and sliding the forks under the blocks as shown. Making sure not to cause damage whilst doing this.



Option A

Tilt and slide pack onto forks as shown in this image.

Option B

Carefully insert the forks into the open space between the steel bridges in the stacked block packs. (Highlighted in red on photo)

Once materials have been offloaded and securely stored on site, you may need to move some products manually. This is possible as long as you follow the below guidance to avoid damage and reduce safety risks.

Thermowall blocks -

- Use appropriate hand protection to avoid getting cut on the metal bridges.
- Carry 1-3 block max at any one time.
- Do not try and carry a full pack manually.

Thermorroof -

- Carry one panel at a time with a person at each end.
- Do not carry panels on your own.
- If lifting over scaffold or onto roof, use more people to help manoeuvre without damaging the panels.

Thermofloor -

- Carry one panel at a time with a person at each end.
- Do not carry panels on your own.
- Do not carry panel by the edges.
- Only lift / carry using the service holes on either end (see photo below).
- If lifting across long floors or over scaffold, use more people to help manoeuvre without damaging the panels.

Storage

The storage of Thermohouse ICF products on site should be assessed dependent on the site conditions adapt the below guidance to suit.

Thermowall Blocks -

- The blocks should be stored internally or under protective cover where possible.
- Where internal storage is not possible, store it in a safe flat surface area within the site.

- The block bales can be stacked on top of each other, taking into consideration the wind as the higher the blocks are the more likely they could topple over by heavy winds causing injury and damage to the blocks.
- Use Timber Bearers as required to improve the stability of the bales.
- Do not stack more than 2 bales high in external site conditions, and you can stack up to 4 bales high in internal storage conditions.
- Store all packed bales in the wrapping until needed, once opened bring all loose blocks to ground level.
- Long term exposure to UV will adversely affect the profile of the blockwork.

Floors & Roof -

- The Floor Panels should be stored internally or under protective cover where possible.
- Where internal storage is not possible, store it in a safe flat surface area within the site.
- As the floor panels are not banded to avoid damage or injury from wind, ensure a heavy weight (Pallet) is stored above the pack as below image.
- The roof panels will be delivered banded.
- Store all panels on timber bearers at spacing of no more than 3mtrs apart.
- Long term exposure to UV will adversely affect the surface of the panels.

Below images show best practice.



Thermofloor



Thermoroof



Thermowall

Charges

All delivery charges are shown on every quote, these are based on the materials specified on that quote and how many loads we think it will take to complete the order. If the materials are taken as quoted no additional charges are to be expected.

If delivery loads are split further than we had allowed, delivery location is changed, smaller lorries are required or any other change which would result in a cost increase, these will be passed on to you.

The site offload time is also allocated to 2 hours maximum, if this is exceeded the haulier will implement a waiting time charge which will be passed on to you.

Once the articulated unit has left for delivery, if the haulier is unable to make the drop on site and is redirected, they will implement a redirection and in some cases storage charge which will be passed on to you.

A failed delivery may include some or all of the above charges being incurred as there are many costs involved in sending the products back to an alternative storage facility.

Damages

Any product which has been damaged in transit must be reported back to us within 24hrs of the delivery taking place.

Photographic evidence is required before/during the unloading of damaged materials.

The Delivery Confirmation Docket must be signed and noted with damage details if applicable.

Contact form

Please ensure the completion and signing of the form provided below, which pertains to all delivery information.

To prevent any delays and ensure accurate information on dispatch, delivery, and the final invoice, it's crucial to provide accurate invoicing details.

Site contacts will serve as the primary point of contact for communication with the office, factory, and the delivery driver.

The individual responsible for completing the form is accountable for verifying that access, unloading, and safe exit from the site are feasible. If these aspects pose challenges, it's advised to discuss alternative delivery methods and associated costs well in advance.



Full Brick Finish to Apartment block

INVOICE & DELIVERY INFORMATION FORM

Invoice Name:	
Full Invoice Address:	
Contact Phone Number:	
Contact email address for invoicing:	
Full site Address:	
Postcode / Eircode for Site:	
Site Contact for deliveries:	
Site Contact Phone Number:	
Confirmation that the delivery can be made by a 45ft Articulated truck with a height of 15.5ft: PLEASE NOTE THAT ANY LOW HANGING CABLES HAVE THE POTENTIAL TO HALT DELIVERY AND TRUCK MAY HAVE TO BE UNLOADED AT THIS POINT. ANY DELIVERIES THAT REQUIRE A SMALLER TRUCK WILL OCCUR ADDITIONAL COSTS BASED ON LOCATION.	
Any additional information relevant to delivery:	
I confirm that I have read and understood the delivery, handling and storage guide supplied	

THERMOHOUSE RESERVES THE RIGHT TO REFUSE DELIVERY IF THE TRUCK CANNOT MAKE SAFE ACCESS TO THE DELIVERY SITE

Design Guidelines – 350mm Blocks

This guideline has been crafted to aid you in accurately determining the required dimensions for your building project using Thermohouse blocks. Adjusting block sizes can help minimize material wastage and streamline the installation process. While we've employed the 350mm block as an example due to its common usage, the same principles apply to the 300mm and 450mm blocks.

Here are some crucial points to consider:

- Most external horizontal measures are based on increments of 150mm, Most wall lengths, external window widths and pillars between ope's are incremental measures (150mm).
- Except when measuring from an external corner to an internal corner, use 150mm increments, but subtract 50mm from the final measurement. This correction compensates for the 350mm block's extra 50mm compared to the 150mm increment. This adjustment ensures that the metal inserts stay aligned vertically.
- In scenarios involving a recess, subtract 100mm (50mm either side).
- If your project features a single internal corner, follow incremental measurements, allocating the additional 50mm closer to the internal corner where insert alignment isn't necessary.
- In instances where wall dimensions are modified, all openings should also be adjusted accordingly based on 150mm increments.

By adhering to these guidelines, you can attain precise measurements and facilitate a seamless progression of your building project. Please consult the diagram below for visual reference.

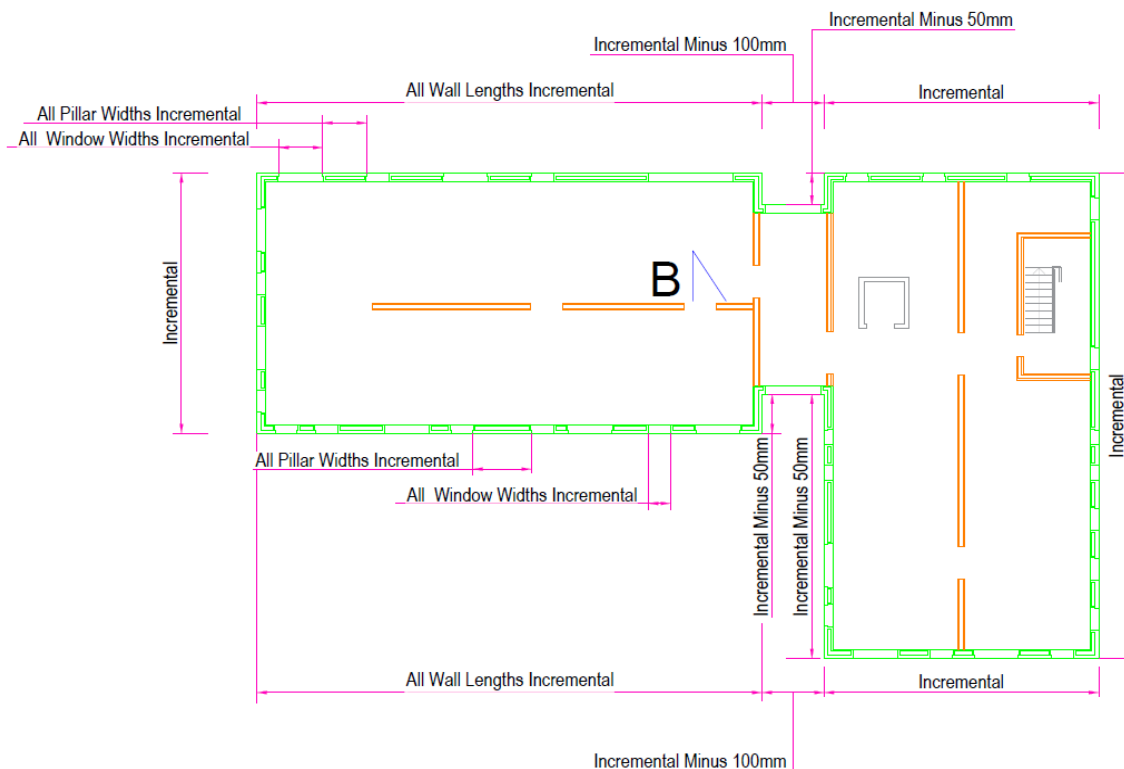

G1 - Design Guidelines



Brick Slip Finish to Apartment Block and Town Houses



the complete low energy building system

Thermowall

Wall System

Thermohouse offers a comprehensive range of external wall systems designed to fulfil diverse requirements, featuring U-values that range from 0.2 to 0.1 W/m²K.

Furthermore, Thermohouse provides specialized external retaining wall systems suitable for basement construction, internal load-bearing walls, and party walls. The versatility of the system extends to applications in swimming pool wall construction as well.

Walls engineered using the Thermohouse ICF system are adept at sustaining and transmitting loads to the ground, ensuring resilience against disproportionate collapse.

The blocks themselves are crafted with an outer leaf, an integrated metal bridging system, and an internal leaf. Notably, the outer leaf of all our blocks is a minimum of one-third larger than the inner leaf, which effectively combats issues related to interstitial condensation.

With a bridging distance of 150mm, the system incorporates a 40mm fixing plate to accommodate a fixing option for the attachment of light weight fixings and plasterboards to the internal face of the blockwork. The 350mm block diagram below provides insight into the block composition. Once all blocks are aligned according to the design guidelines, the steel bridging plates feature vertical rebar holes for easy and accurate positioning of the anti-crack reinforcement @ 1.050m centres.



Phase 3 - Thermohouse Development Co. Kerry

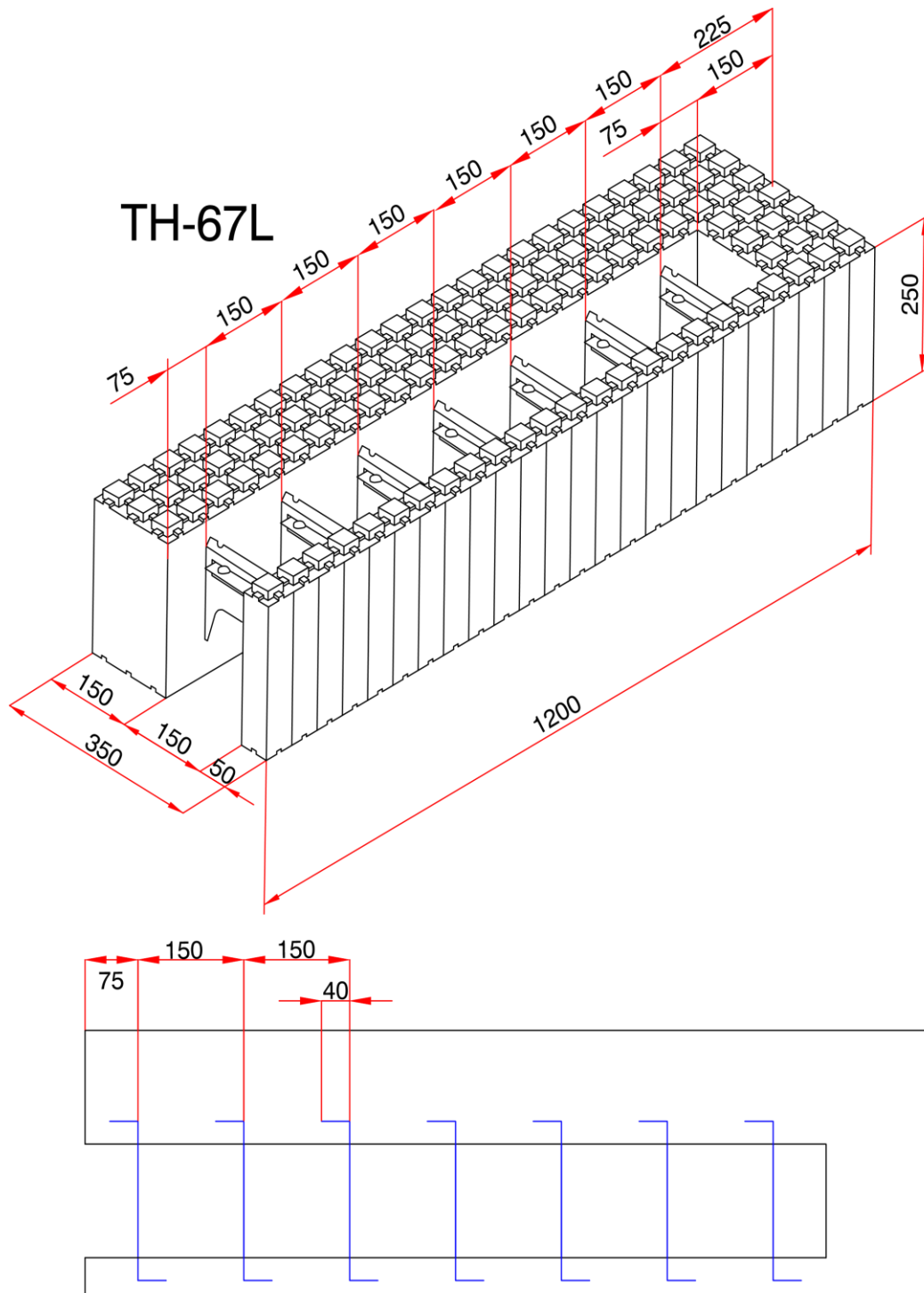

External Wall Element

Thermohouse - 350 Standard Element 34

Thermowall



The Thermowall elements, made of expanded polystyrene (EPS), are applied as the formwork for plain or reinforced concrete walls cast in-situ. The Thermowall elements comprise of two leaves of EPS, the inside leaf is always 50mm the outer leaf varies in thickness depending on required U value. The leaves are connected by steel inserts to resist the pressure of the concrete during filling and vibrating. The upper and lower surfaces of the shuttering leaves are designed to interlock during construction.

Size, Weight & Technical

Thermal Conductivity (EPS)	0.030W/mK		
Density	24kg/m ³		
Block Description	Size in mm (W x H x L)	U- Value	Weight
Internal Load Bearing Block	250 x 250 x 1200	-	1.85 Kg
Internal Party Wall Block	300 x 250 x 1200	-	2.10 Kg
External Standard Block	300 x 250 x 1200	0.20W/m ² K	2.21 Kg
External Passive Standard Block	350 x 250 x 1200	0.15W/m ² K	2.75 Kg
External Passive Gold Block (special order only)	400 x 250 x 750	0.12W/m ² K	2.04 Kg
External Passive Platinum Block (special order only)	450 x 250 x 750	0.10W/m ² K	2.25 Kg
Basement Block Standard	350 x 250 x 1200	0.20W/m ² K	2.37 Kg
Basement Block Passive	400 x 250 x 1200	0.15W/m ² K	2.90 Kg

Fire Rating	
External Fire Spread	Class 0

Materials
EPS with Pressed steel bridging

Commercial	
Typical Use	Load bearing walls for use in Domestic & Commercial buildings. Can achieve air tightness of <2m ³ /(hr.m ²)

Wall Elements

The general block sizes manufactured as stock are shown below. All build ups shown are external leaf/core/internal leaf along with the U-Value each size block achieves. A 400mm block made up 200/150/50 achieving a U-Value of 0.12 can only be made as a special-order product, usually at longer lead times than the regular stock range. This range has not been included in this manual, but it would be in the same format as the 450mm block only being 400mm x 250 x 750

Retaining Walls

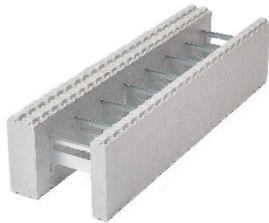

External Standard Retaining Wall Block 350mm

(100/200/50)
U Value = 0.195 W/m²K

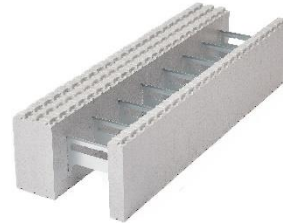

External Passive Retaining Wall Block 400mm

(Special Order Only)

(150/200/50)
U Value = 0.195 W/m²K

External walls

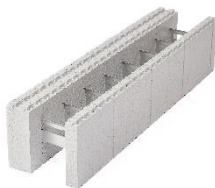

External Standard Wall Block 300mm

(100/150/50)
U Value = 0.195

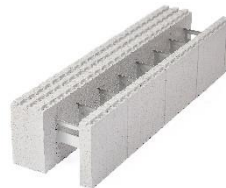

External Passive Standard Wall Block 350mm

(150/150/50)
U Value = 0.15



External Passive Platinum Wall Block 450mm

(250/150/50)
U Value = 0.10

Internal Wall



Internal Load Bearing Wall Block 250mm

(50/150/50)



Internal Party Wall Block 300mm

(50/200/50)

Thermohouse Wall Block Range

350mm Standard Retaining Wall Block
U-Value of 0.20
(100/200/50)

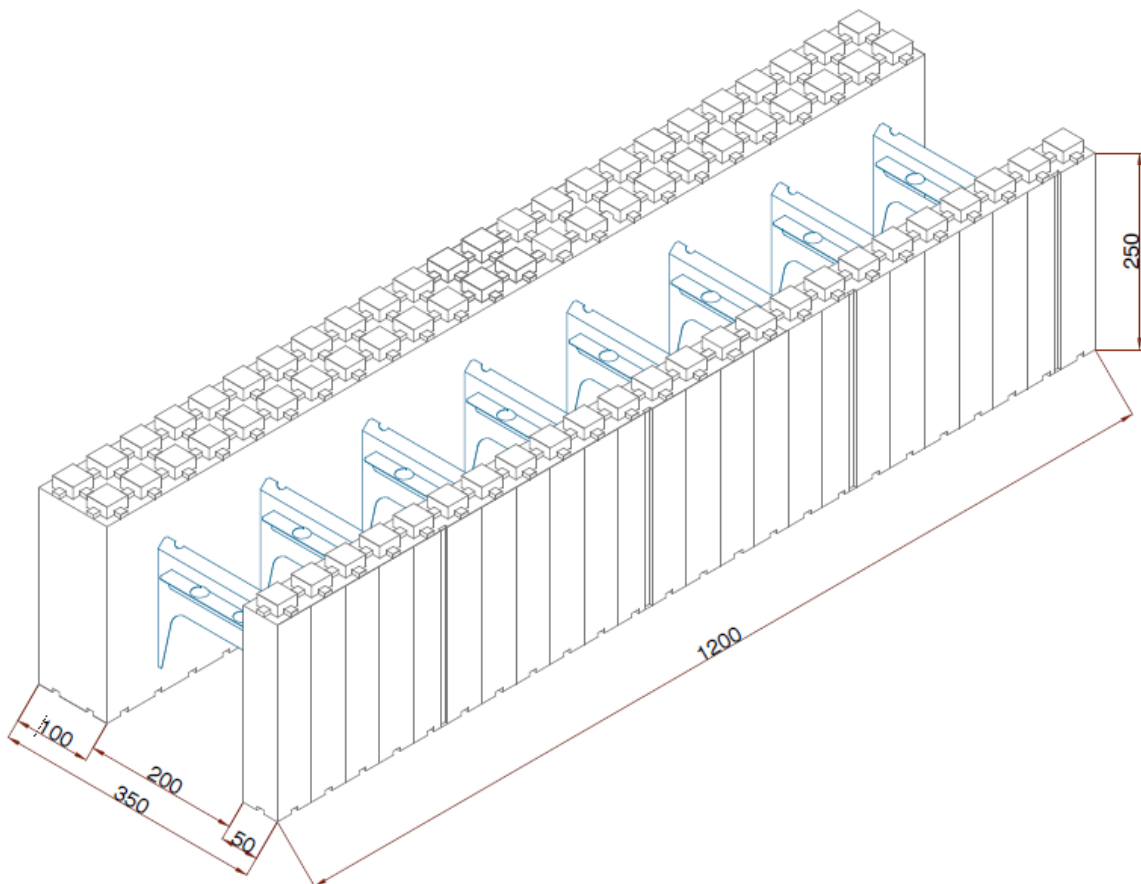

350mm Standard Retaining Wall Block Family

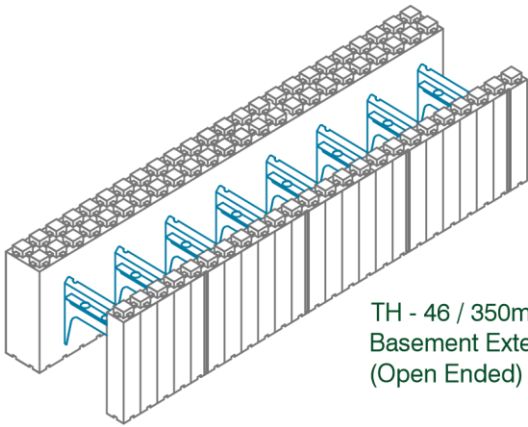

TH - 46 / 350mm
Basement External Wall
(Open Ended)

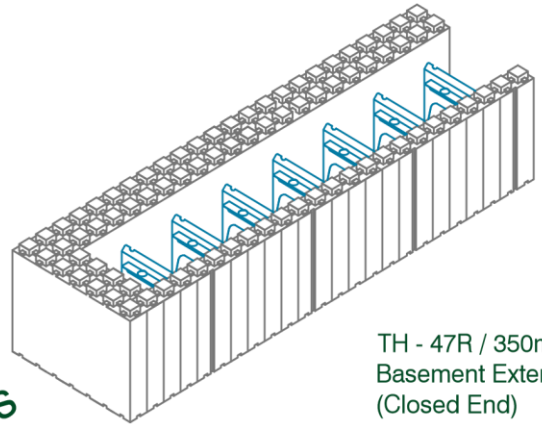

TH - 47R / 350mm
Basement External Wall
(Closed End)

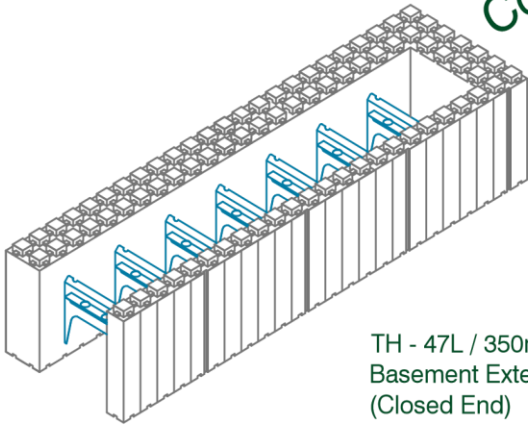

TH - 47L / 350mm
Basement External Wall
(Closed End)

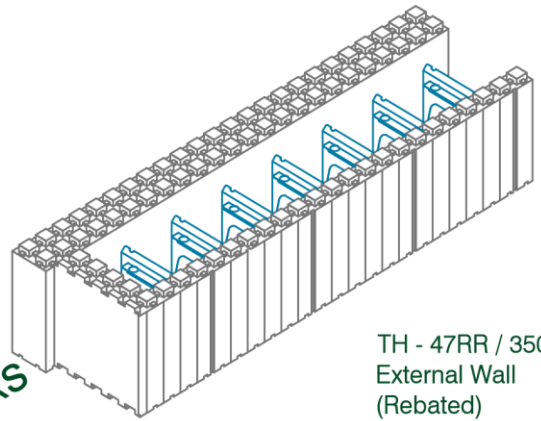

TH - 47RR / 350mm
External Wall
(Rebated)

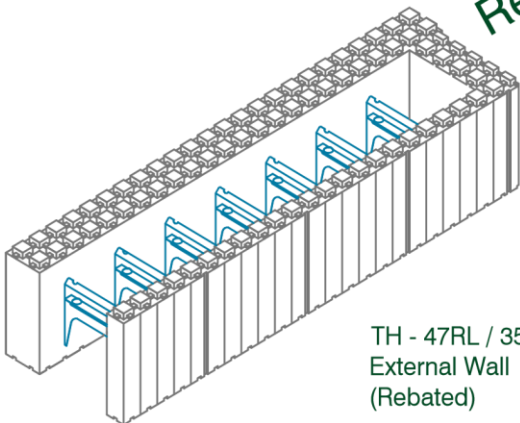

TH - 47RL / 350mm
External Wall
(Rebated)

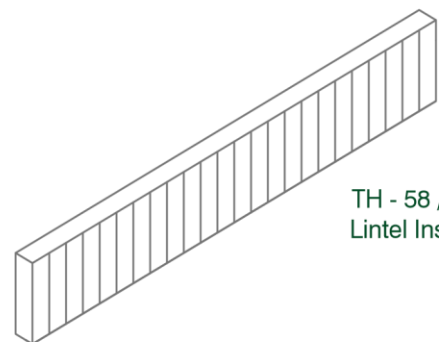

TH - 58 / 200mm
Lintel Insert

Corner Blocks

Reveal Blocks

400mm Passive Retaining Wall Block

U-Value of 0.15
(150/200/50)

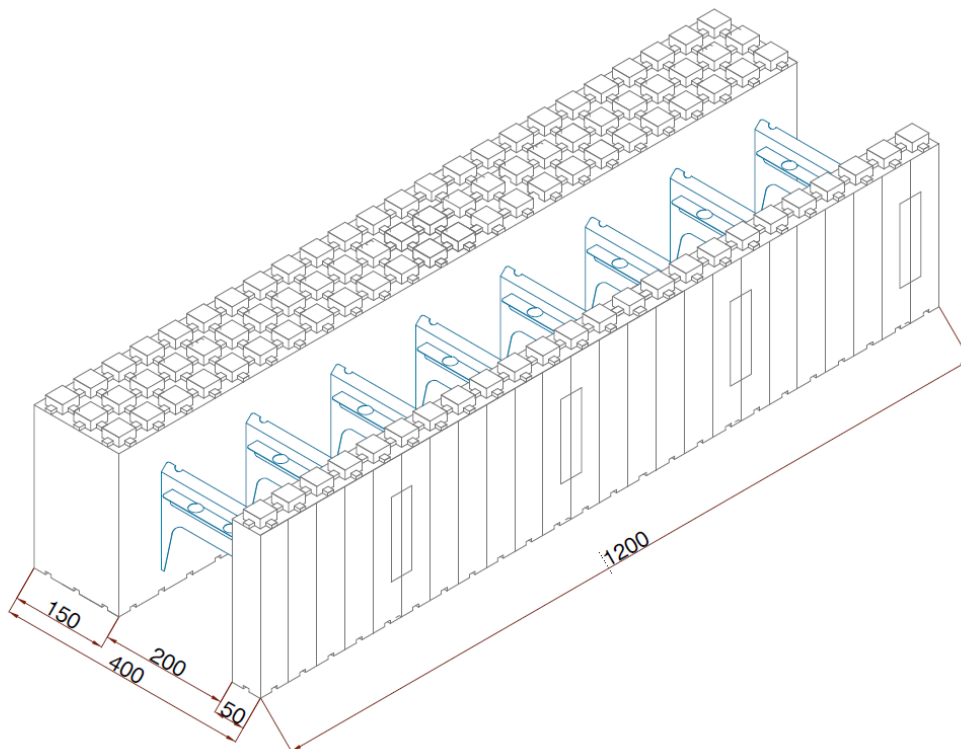

400mm Passive Retaining Wall Block Family

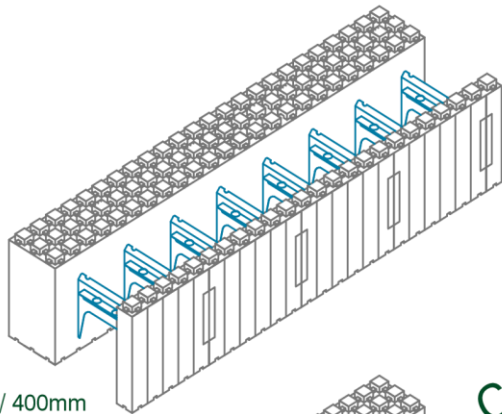

TH - 76 / 400mm
Basement External Wall
(Open Ended)

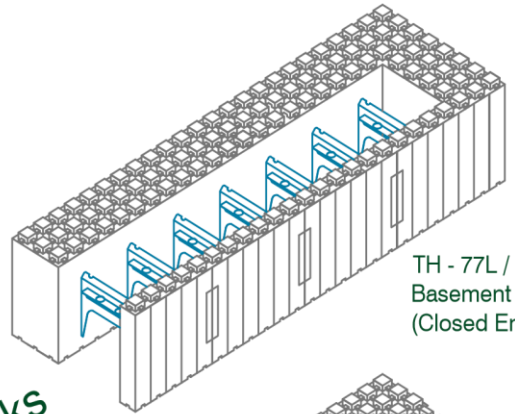

TH - 77L / 400mm
Basement External Wall
(Closed End)

Corner Blocks

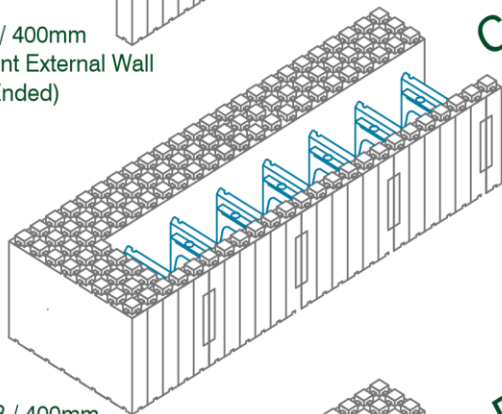

TH - 77R / 400mm
Basement External Wall
(Closed End)

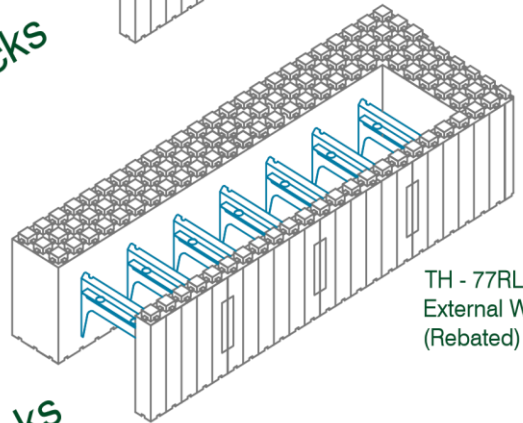

TH - 77RL / 400mm
External Wall
(Rebated)

Reveal Blocks

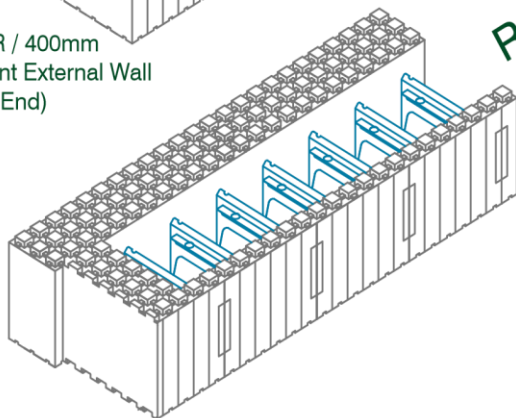

TH - 77RR / 400mm
External Wall
(Rebated)

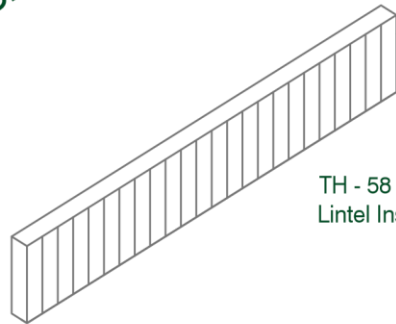

TH - 58 / 200mm
Lintel Insert

300mm External wall block

U-Value of 0.195
(100/150/50)

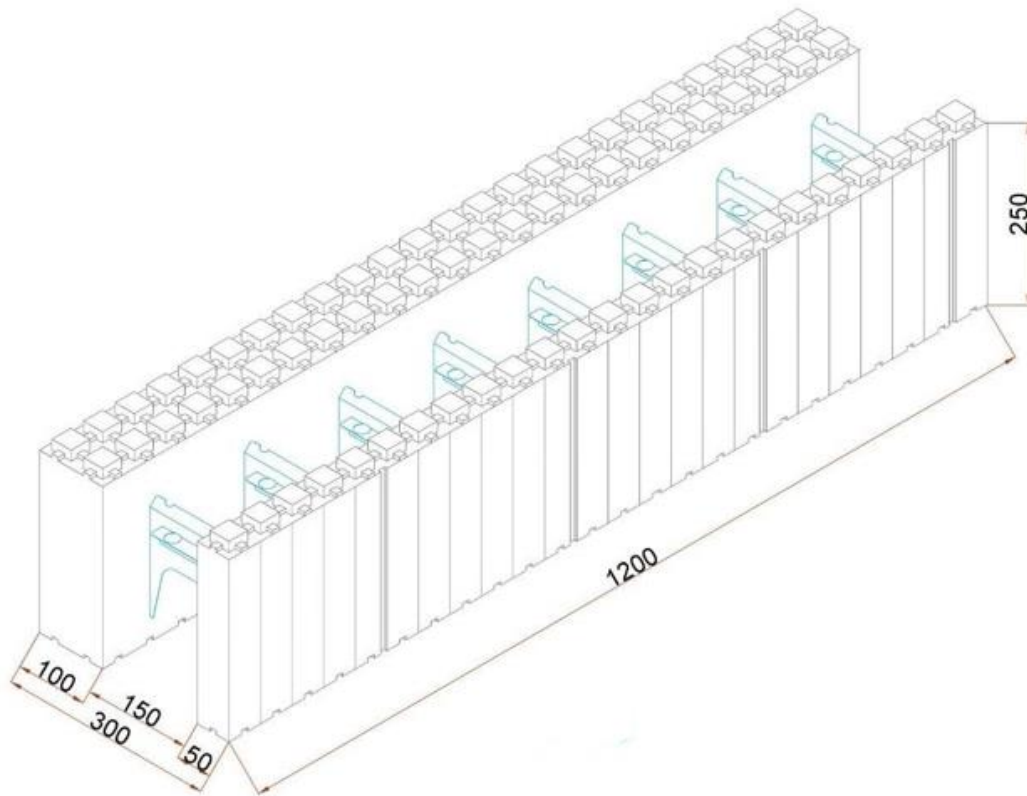
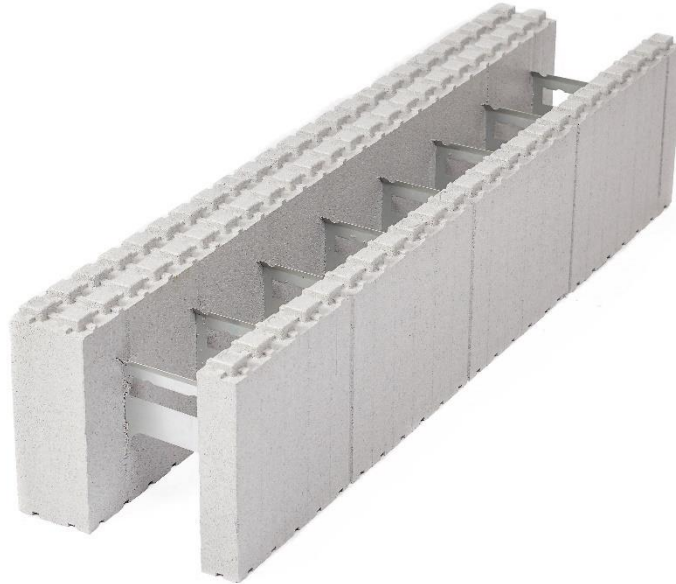

300mm External wall block family

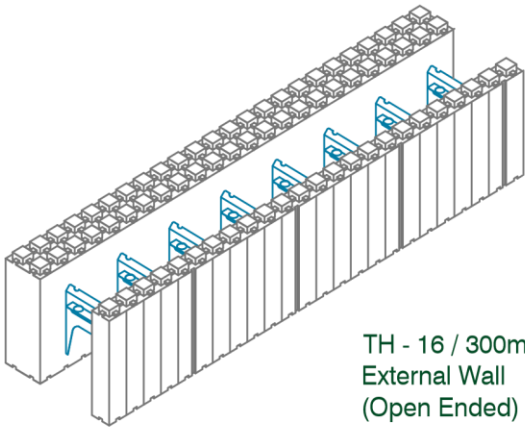

TH - 16 / 300mm
External Wall
(Open Ended)

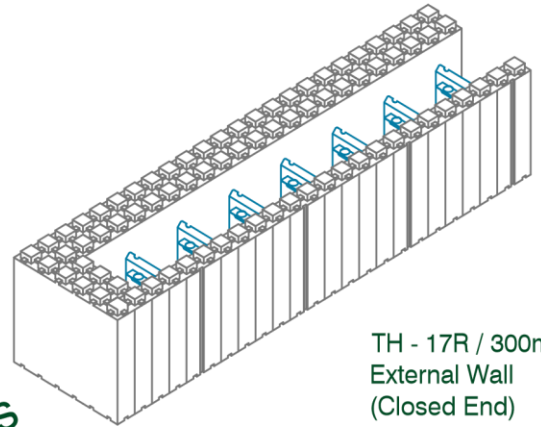

TH - 17R / 300mm
External Wall
(Closed End)

Corner Blocks

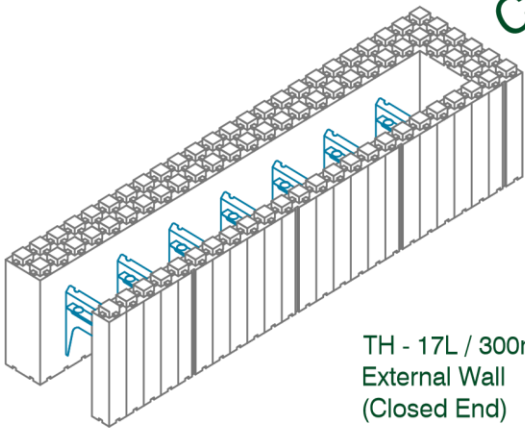

TH - 17L / 300mm
External Wall
(Closed End)

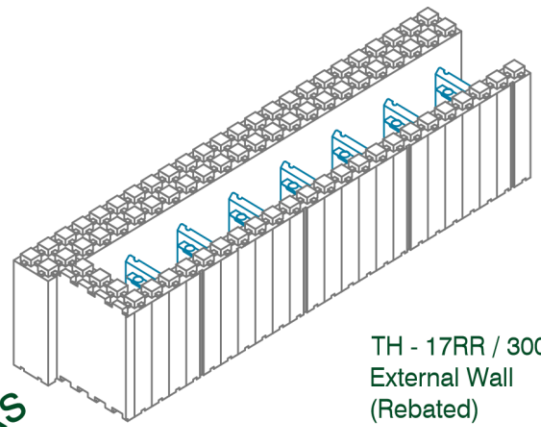

TH - 17RR / 300mm
External Wall
(Rebated)

Reveal Blocks

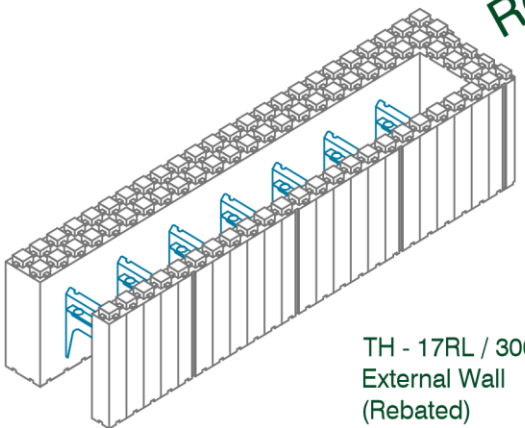

TH - 17RL / 300mm
External Wall
(Rebated)

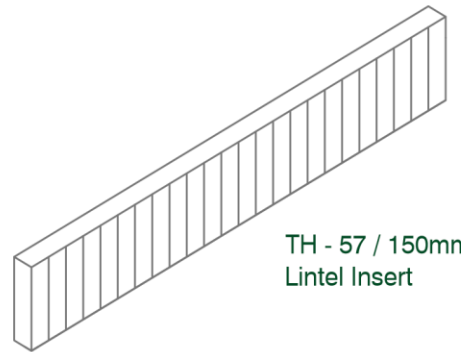

TH - 57 / 150mm
Lintel Insert

350mm External wall block

U-Value of 0.15
(150/150/50)

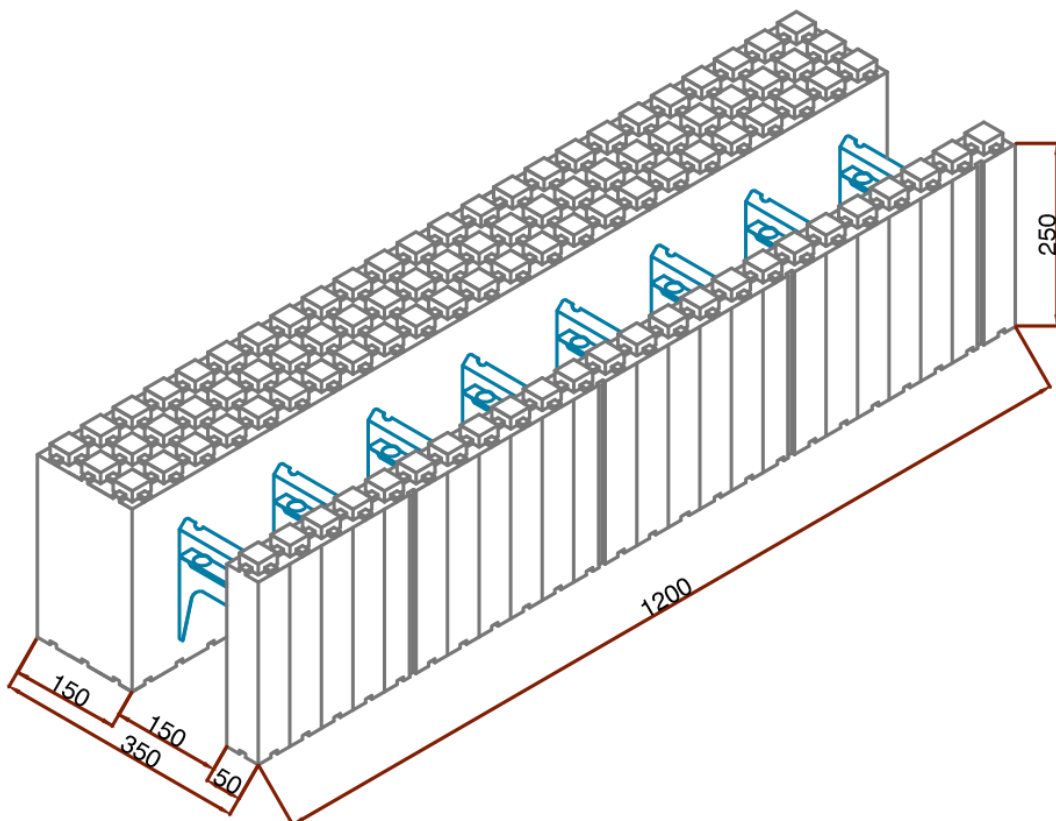
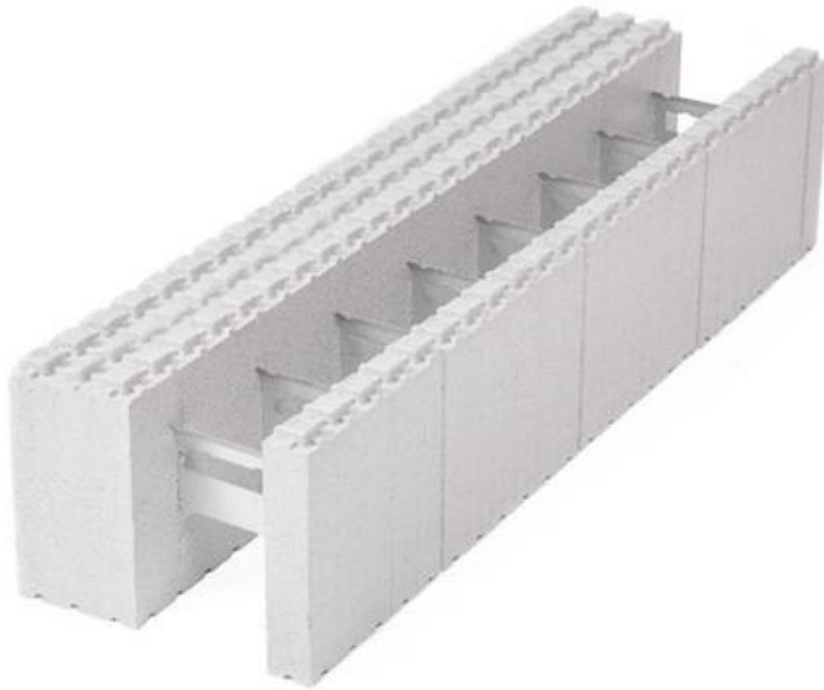

350mm External block family

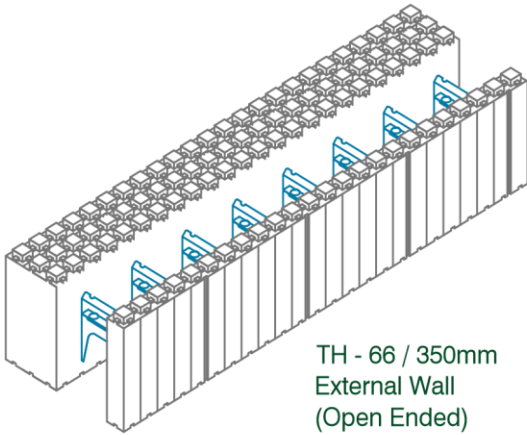

TH - 66 / 350mm
External Wall
(Open Ended)

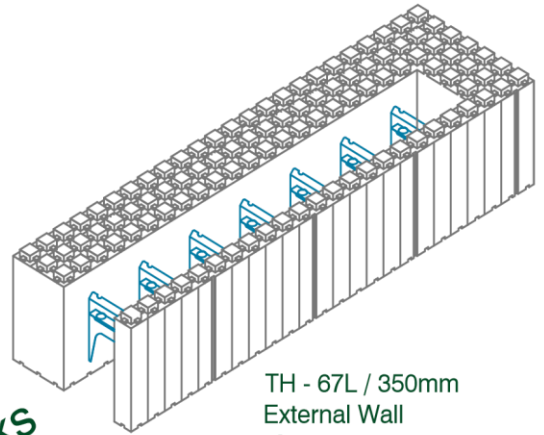

TH - 67L / 350mm
External Wall
(Closed End)

Corner Blocks

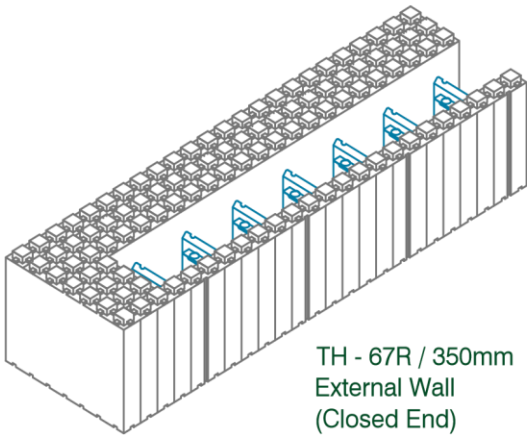

TH - 67R / 350mm
External Wall
(Closed End)

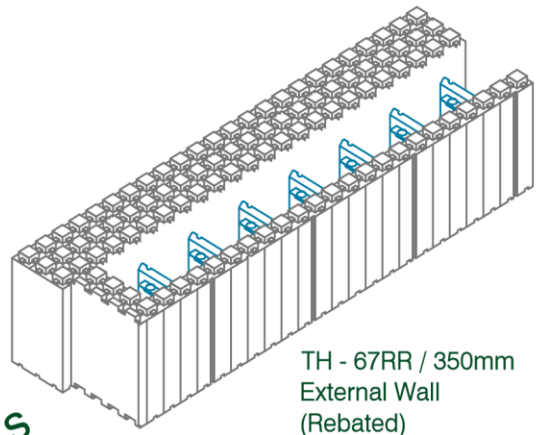

TH - 67RR / 350mm
External Wall
(Rebated)

Reveal Blocks

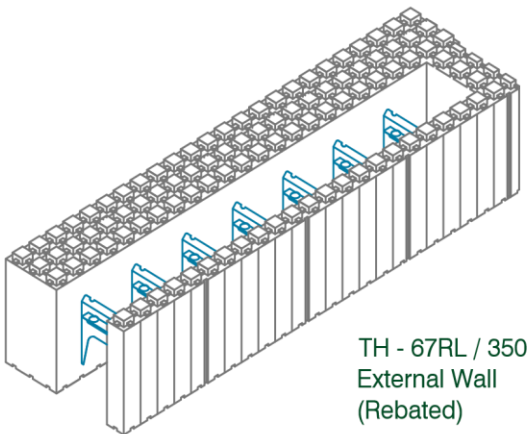

TH - 67RL / 350mm
External Wall
(Rebated)

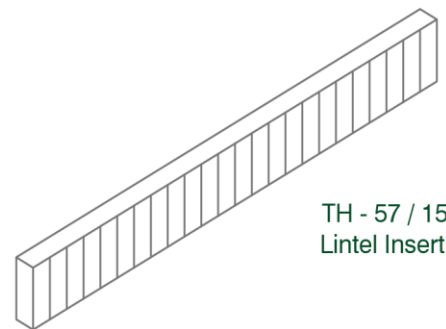

TH - 57 / 150mm
Lintel Insert

450mm External wall block

U-Value of 0.10
(250/150/50)

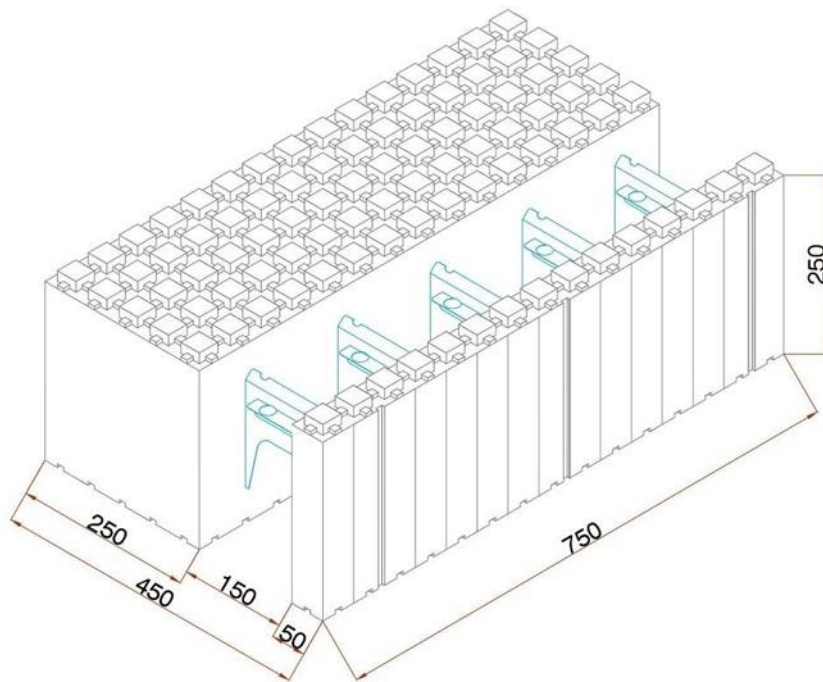
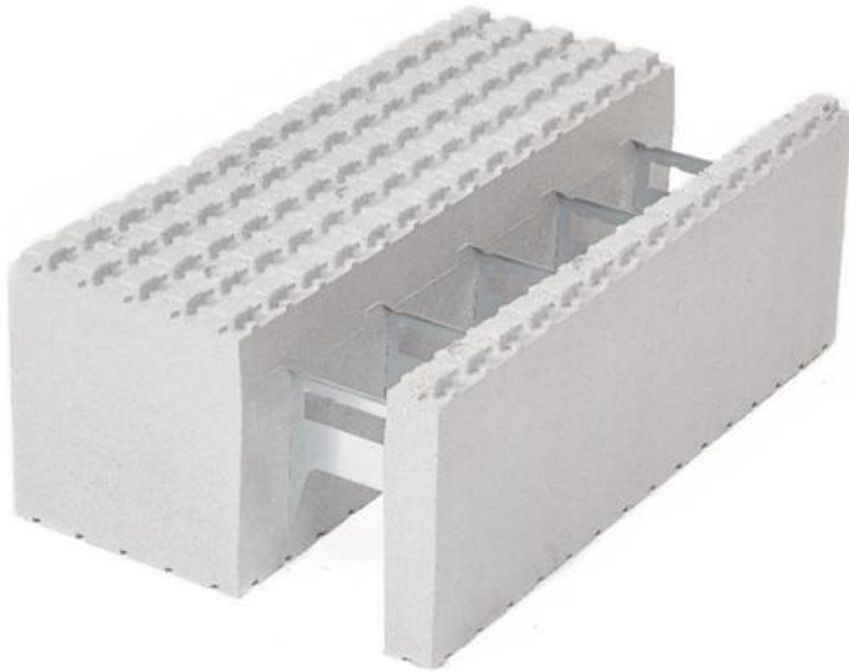

450mm External wall block family

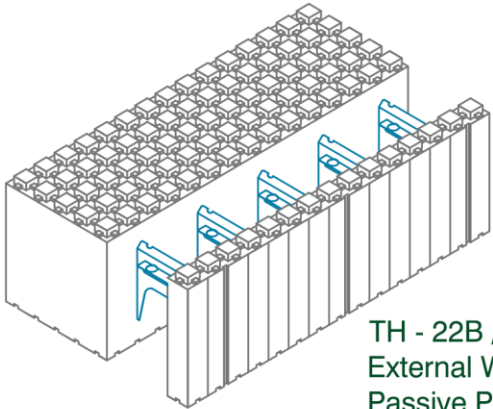

TH - 22B / 450mm
External Wall
Passive Platinum
(Open Ended)

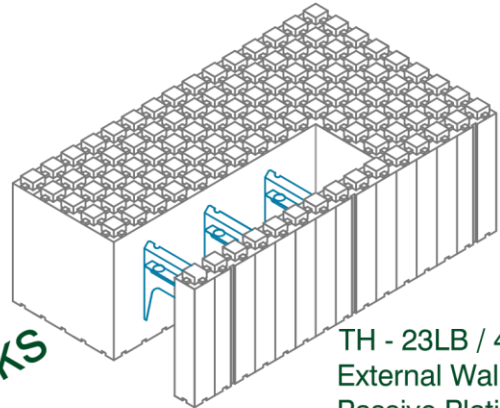

TH - 23LB / 450mm
External Wall
Passive Platinum
(Closed End)

Corner Blocks

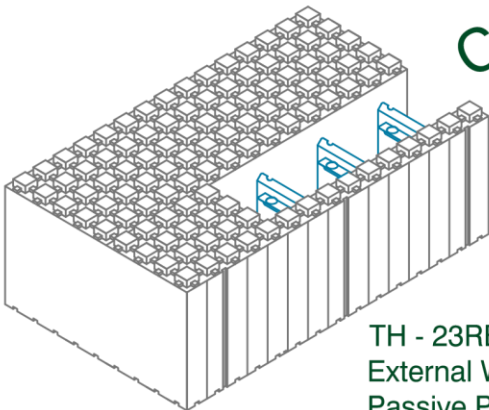

TH - 23RB / 450mm
External Wall
Passive Platinum
(Closed End)

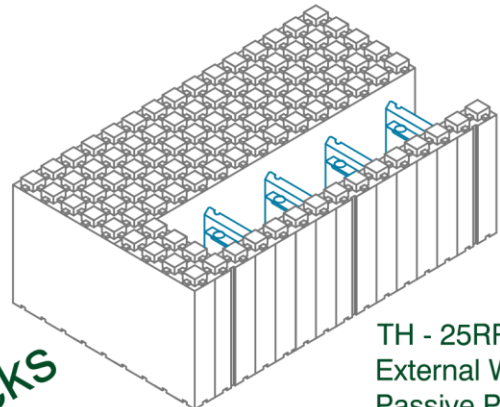

TH - 25RRB / 450mm
External Wall
Passive Platinum
(Closed End)

Reveal Blocks

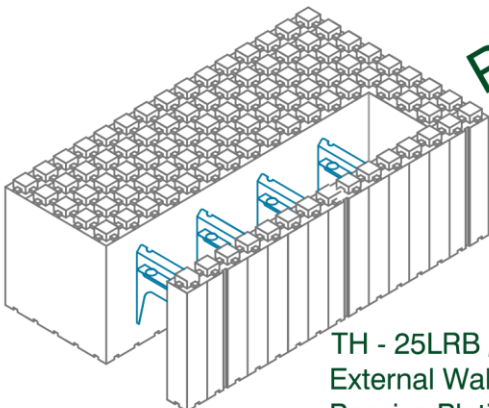

TH - 25LRB / 450mm
External Wall
Passive Platinum
(Closed End)

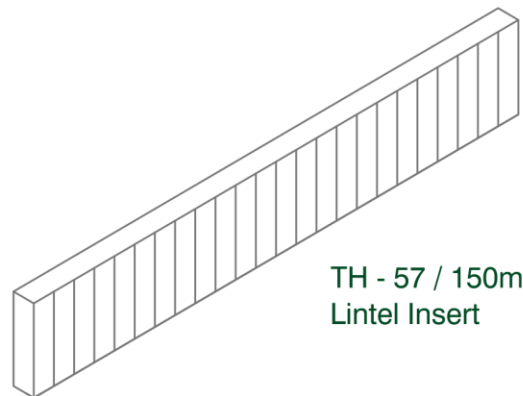

TH - 57 / 150mm
Lintel Insert

Please Note – all 450mm wall blocks around doors & windows will be manufactured as standard flush end face, if a 25mm reveal is required it needs to be stated prior to ordering.

250mm Internal load bearing wall block
(50/150/50)

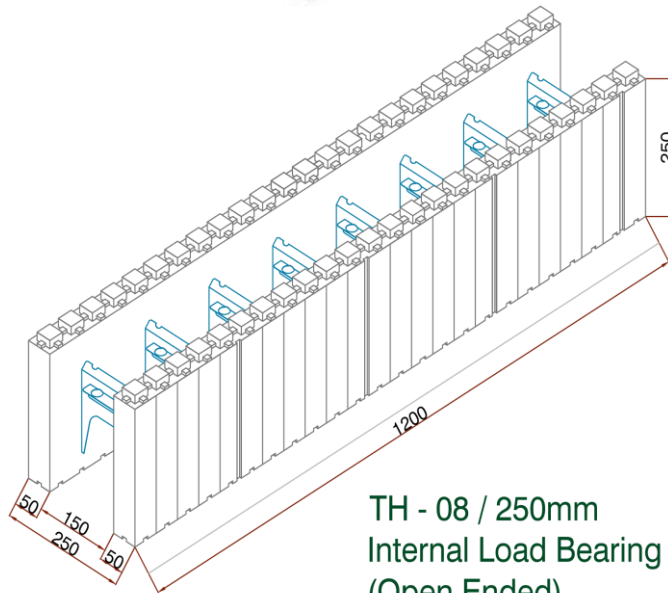

TH - 08 / 250mm
Internal Load Bearing Wall
(Open Ended)

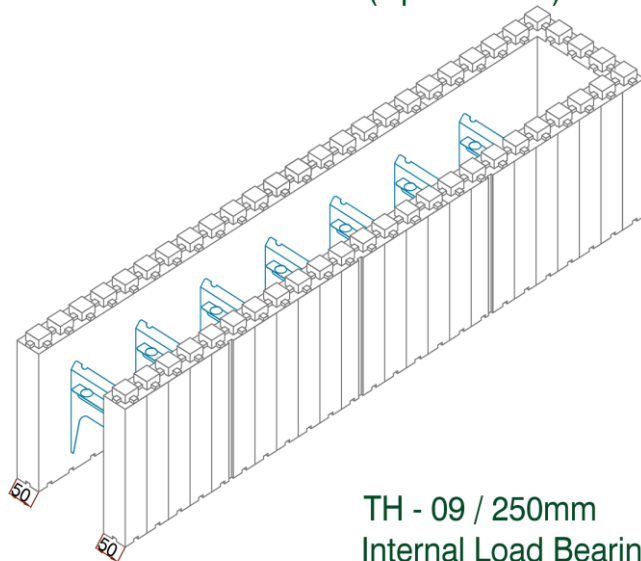

TH - 09 / 250mm
Internal Load Bearing Wall
(Closed End)

300mm Party wall block
(50/200/50)

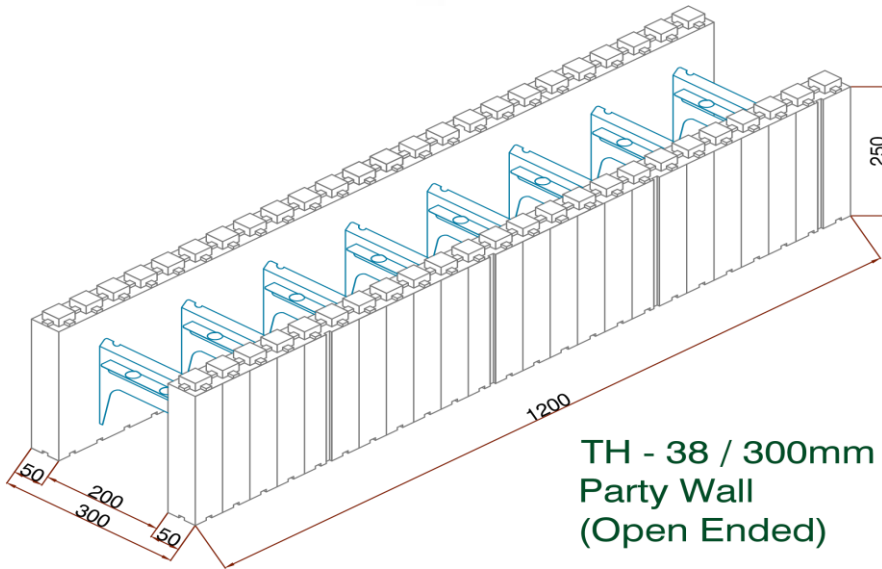

**TH - 38 / 300mm
Party Wall
(Open Ended)**

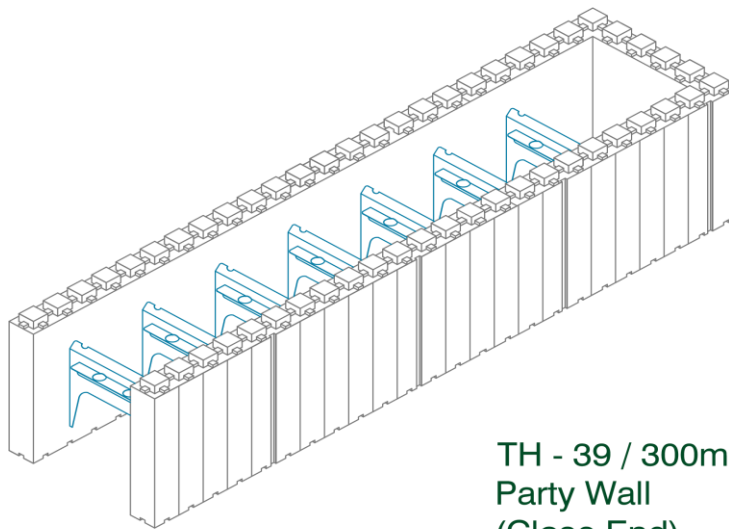

**TH - 39 / 300mm
Party Wall
(Close End)**

Independent wall components

TH - 57 / 150mm
Lintel Insert

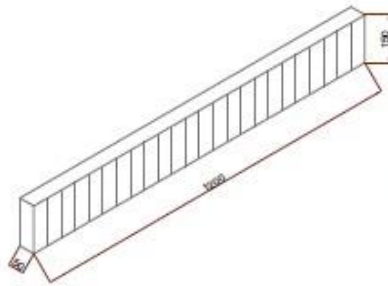

TH - 21 / 100mm
External Insulation Leaf

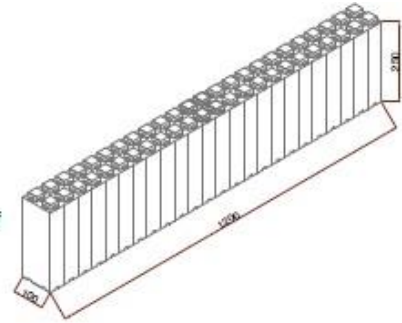

TH - 58 / 200mm
Lintel Insert

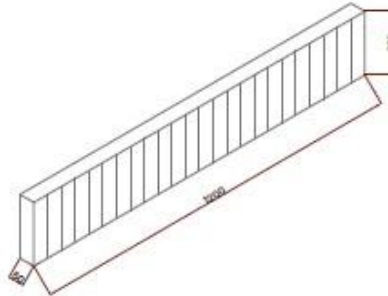

TH - 61 / 150mm
External Insulation Leaf

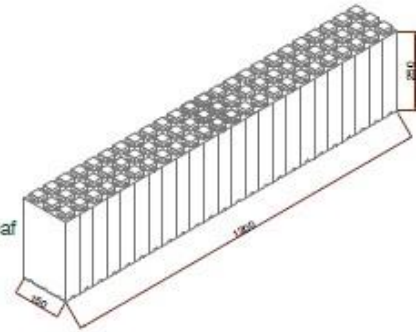

TH - 20 / 50mm
Floor Edge

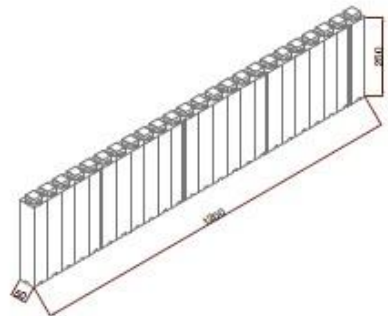

TH - 19 / 200mm
External Insulation Leaf

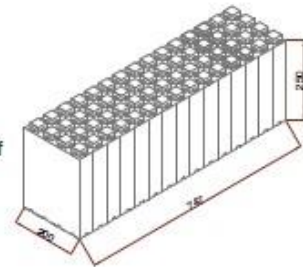

TH - 19a / 50mm
Internal Insulation Leaf

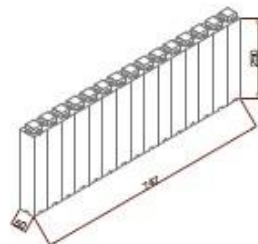

TH - 24 / 250mm
External Insulation Leaf

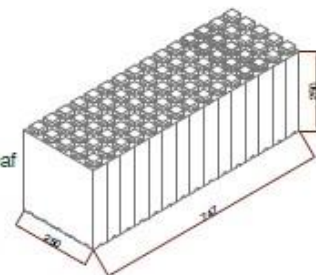

Thermowall



The Thermowall elements, made of expanded polystyrene (EPS), are applied as the formwork for plain or reinforced concrete walls cast in-situ. The Thermowall elements comprise of two leaves of EPS, which are connected by steel inserts to resist the pressure of the concrete during filling and vibrating. The upper and lower surfaces of the shuttering leaves are tongue and groove to place the elements together.

Size, Weight & Technical			
Thermal Conductivity (EPS)		0.030W/mK	
Density		24kg/m ³	
Block Description	Size in mm (D x H x L)	U- Value	Weight
Internal Load Bearing Block	250 x 250 x 1200	-	1.85 Kg
Internal Party Wall Block	300 x 250 x 1200	-	2.10 Kg
External Standard Block	300 x 250 x 1200	0.20W/m ² K	2.21 Kg
External Passive Standard Block	350 x 250 x 1200	0.15W/m ² K	2.75 Kg
External Passive Gold Block	400 x 250 x 750	0.12W/m ² K	2.04 Kg
External Passive Platinum Block	450 x 250 x 750	0.10W/m ² K	2.25 Kg
Basement Block Standard	350 x 250 x 1200	0.20W/m ² K	2.37 Kg
Basement Block Passive	400 x 250 x 1200	0.15W/m ² K	2.90 Kg

Fire Rating

External Fire Spread Class 0

Materials

EPS with Pressed steel Bridging

Commercial

Typical Use Load bearing walls for use in Domestic & Commercial Buildings. Can achieve air tightness of <math><2\text{m}^3/(\text{hr}\cdot\text{m}^2)</math>

Contact Us

Phone: 0203 771 7426

Email: info@thermohouse.co.uk

Website: www.thermohouse.co.uk



Essential installation components



Low expanding adhesive foam (suitable for EPS)
Image source: fischer group of companies (similar products from other manufacturers may be used)



Dispensing Gun
Image source: fischer group of companies (similar products from other manufacturers may be used)



Galvanised heavy duty ratchet strainer



Galvanised mild Steel Straining wire 2.5mm (12 Gauge)



Tying wire



Gloves

Basement Construction

Thermohouse offers retaining wall elements in both 350mm and 400mm sizes, facilitating basement construction. Our standard basement forms feature a 200mm concrete core, engineered with retaining wall capabilities. These blocks can also find use in other parts of the build for engineering purposes.

The 350mm elements ($U=0.195$) have a width of 350mm, with external insulation of 100mm and internal insulation of 50mm. The 400mm elements ($U=0.15$) are 400mm wide, with 150mm external insulation and 50mm internal insulation.

The construction approach for basement formwork aligns with the method detailed in the subsequent section on Wall Construction for the standard 350mm formwork. The only deviation involves the inclusion of starter bars (as specified by the Supervising Engineer) extending from the foundation/raft to the wall. This is necessary to counteract ground shear forces.

It's crucial to note that all Insulated Concrete Formwork (ICF) basements **must** be externally tanked as the primary line of defence. In some cases, a secondary line of defence might also be necessary depending on the building regulations that apply in the location of the build. While standard construction might rely on waterproof concrete, this approach is not suitable for ICF construction. Instead, an alternative involves installing an internal tanking system as the second line of defence. Multiple methods and systems can achieve this, and consultation with specialists in this field is recommended.

Multi-storey basement construction is also feasible within the Thermohouse system. Examples of two-storey basement construction are illustrated in photographs on the subsequent pages. These examples feature a 650mm double wall on the lower level engineered to address ground shear forces, transitioning to a 350mm wall for the upper basement level. The Thermohouse building system accommodates variations in design criteria.

Basement Construction Checklist

When considering basement construction using Thermohouse elements, keep the following points in mind to ensure a successful and well-executed project:

Element Options: Thermohouse offers both 350mm and 400mm retaining wall elements suitable for basement construction. Evaluate your project's requirements to determine the most appropriate size.

Concrete Core: Standard basement forms come with a 200mm concrete core. This core can be engineered to have retaining wall capabilities. Assess the engineering needs of your project and make informed decisions about core specifications.

Insulation Configuration:

350mm Elements: These elements feature a width of 350mm, with 100mm of external insulation and 50mm of internal insulation.

400mm Elements: With a width of 400mm, these elements have 150mm of external insulation and 50mm of internal insulation.

Construction Approach: The construction methodology for basement formwork aligns with the process detailed in the Wall Construction section for the standard 350mm formwork. Ensure your design team is familiar with this approach.

Starter Bars: Be aware that starter bars (as specified by the Supervising Engineer) are required from the foundation/raft to the wall. These bars counteract ground shear forces and are vital for structural stability. *Starter bars are not required if the wall is not acting as a retaining wall.*

Tanking Requirements:

Primary Defence: All Insulated Concrete Formwork (ICF) basements must be externally tanked as the primary line of defence against water ingress.

Secondary Defence: Depending on the project, a secondary line of defence might be necessary. Remember that waterproof concrete alone is inadequate for ICF construction. Consider installing an internal tanking system as a second line of defence.

Specialist Consultation: If internal tanking is required, consult specialists in this field to determine the most suitable method or system for your project's needs. A project engineer should also be engaged to ensure all design calculations and overall building design is considered to work in line with the basement requirements.

Multi-Storey Construction: Explore the potential for multi-storey basement construction within the Thermohouse system. Examples of two-storey basement construction are provided in photographs on subsequent pages. Take inspiration from these examples if your project calls for multi-storey basements.

Design Flexibility: Keep in mind that the Thermohouse building system is designed to accommodate variations in design criteria. Utilise the system's flexibility to tailor your basement construction to your project's unique requirements.

By following these guidelines and considering the specifics of your project, you can navigate basement construction using Thermohouse elements effectively and achieve your desired outcomes.

Typical Basement detail (for reference only)

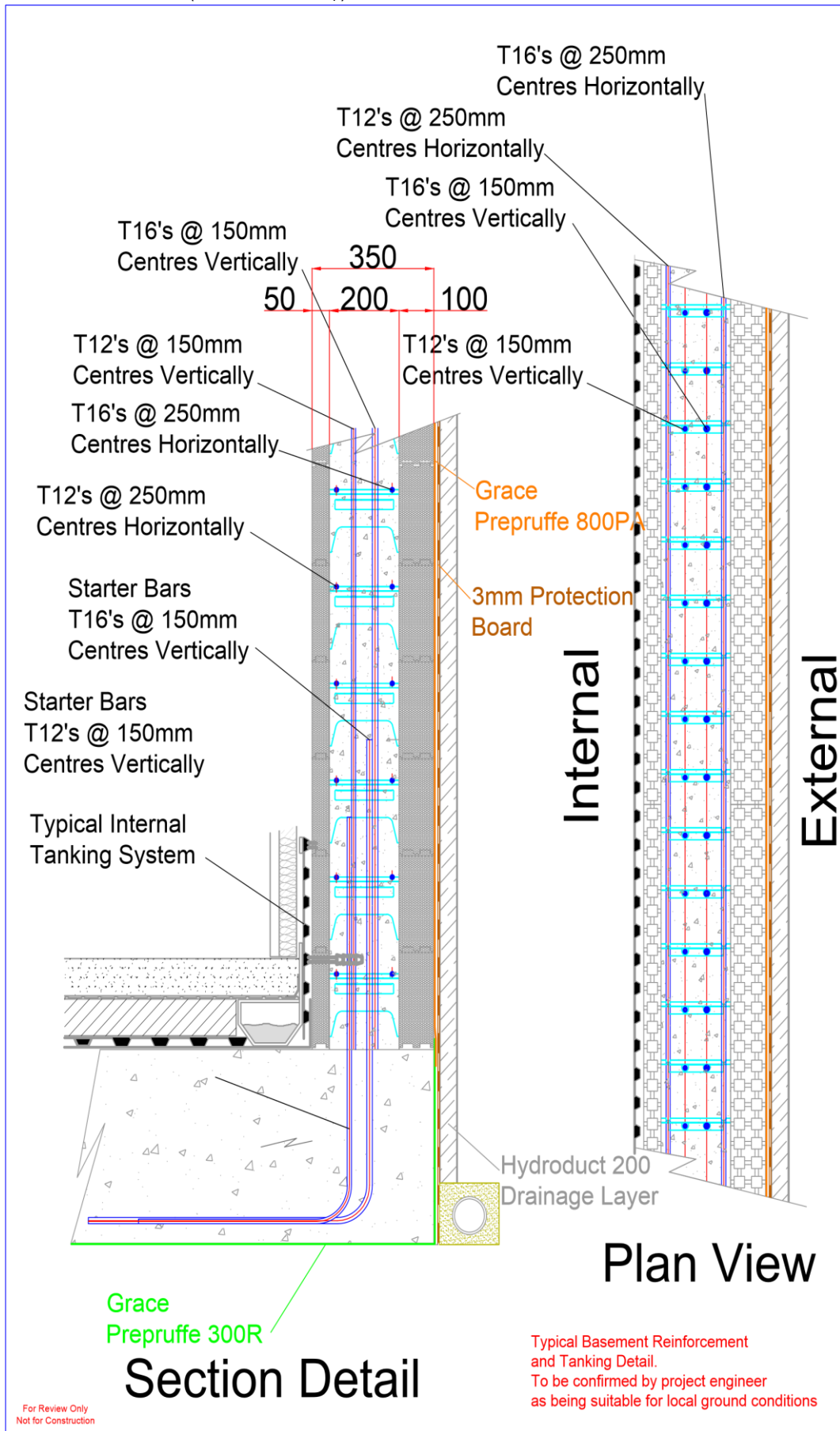

F1 Typical Reinforcement + Int. & Ext. Tanking Detail

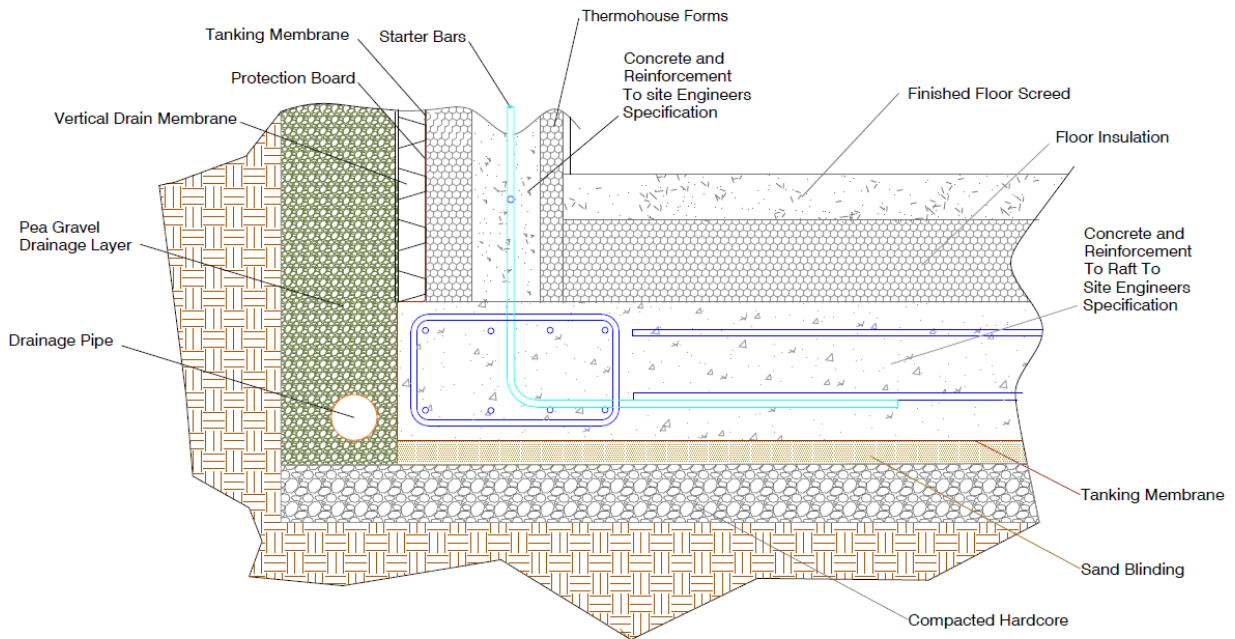

F2 - Typical Basement Raft Foundation Detail

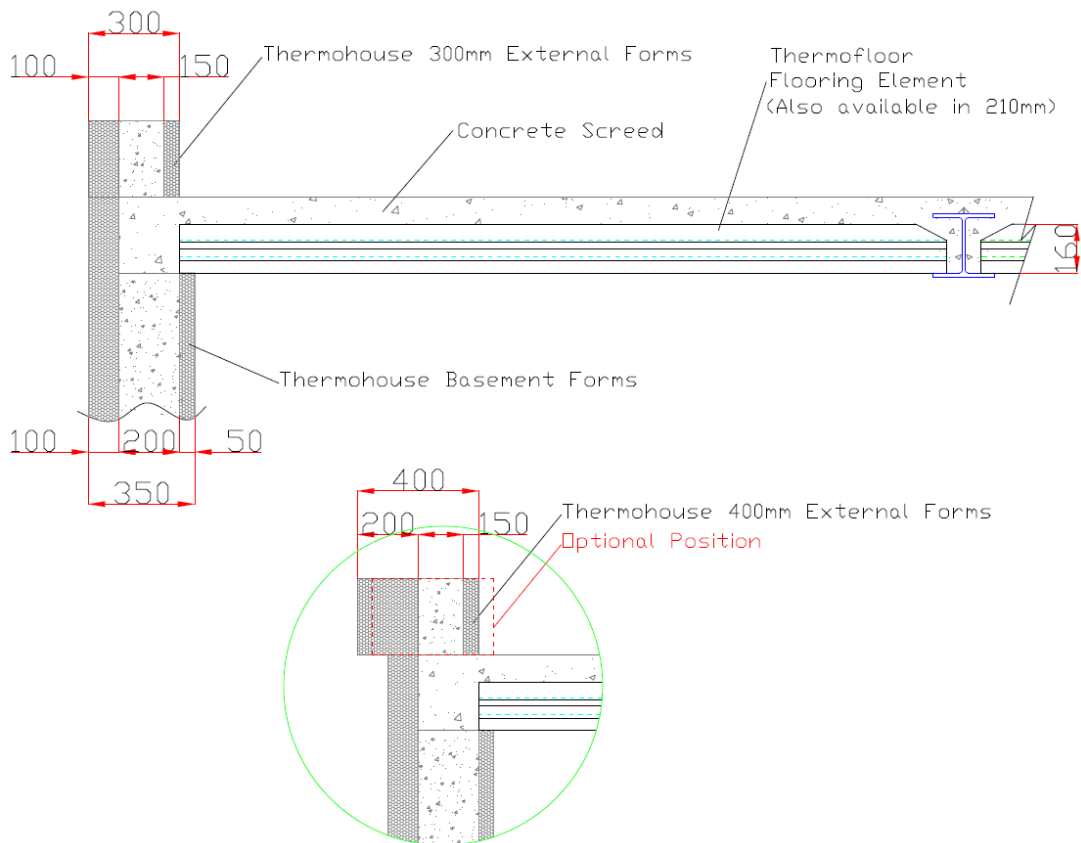

W13 - Typical External wall build up on Thermofloor above 350mm Basement block

Single Storey Basements



Standard basement construction



A tanking detail with drainage stone to basement wall

Multi-Story Basements



Construction of two storey basement



**First Storey Basement Wall (650mm Double Wall)
The second storey was erected with a single basement 350mm**



Lower Basement Incorporating Swimming Pool



Lower basement showing initial tanking layer



Typical Tanking membrane detail

Basement Wall Construction Guidelines

To ensure a successful Thermohouse project, creating an accurate wall layout is of utmost importance. Follow these steps to navigate the process effectively:

Starter Bars Placement: Ensure the placement of starter bars in the foundation/raft is strategic, avoiding clashes with the metal inserts in the formwork. Before commencing, verify the plans to ensure the correct foundation layout and dimensions. Employ an Electric Distance Measure (EDM) or a string line to mark the wall layout on the footings.

Confirm Layout Alignment: Verify that the wall layout aligns precisely with the *Thermohouse set-out plans*. Ensure the outer face of the elements aligns with the overall building dimensions. Check and confirm that all 90-degree corners are both squared and plumb.

Horizontal Wall Layout: Horizontal wall layout dimensions should be chosen in increments of 50mm. This facilitates the secure interlocking of the blocks. However, aim for increments of 150mm, where possible, to reduce material waste, maintain insert alignment, and enable the seamless installation of vertical reinforcing bars through the retaining lugs in the inserts.

Determining Exact Wall Height: Before embarking on the first course of elements, ascertain the exact wall height required for your project. Thermohouse elements have a standard height of 250mm.

If your storey height isn't evenly divisible by 250mm, you have the option to cut either the first or last course of block elements horizontally to fit, or you may require to use the individual EPS leaves to achieve your build height.

Course Laying and Positioning: Before placing the initial course of blocks, double-check the layout's accuracy, refer to the *Thermohouse set-out drawing* for the project. Lay out measurements with increments of 150mm where possible. Always position blocks with the protruding interlock facing upwards. Start your installation from a corner and consistently utilise the same handed corner block for each external corner of each course.

Important Note for Basement Construction: For basement construction, ensure that any EPS bridging the cavity in corners is entirely removed as corner blocks (TH-47R/47L or TH-77R/77L) are positioned. Alternatively, establish a corner using a stepped TH-46 or 76 joint (as depicted in Figure 1). Alternate the direction between courses to ensure proper concrete flow and interlocking while shaping the corner.

In either scenario, offer robust support and shuttering for the concrete installation process in the corner area.

By meticulously following these steps, you can establish an accurate wall layout, promoting the success of your Thermohouse project while ensuring a smooth and efficient construction process.

Accurate Footings & Slabs

The Thermohouse building system can be initiated from various types of standard foundations. Additionally, starting from ground floor level is feasible, allowing construction up to DPC (damp proof course) level using traditional concrete blocks. In this scenario, it's crucial to ensure that the blockwork is aligned and built to suit the specifications for the subsequent *Thermohouse ICF construction set-out drawing*.

The initial step toward a successful Thermohouse installation is establishing a precise strip or raft foundation. It's vital that the concrete's finished surface maintains a level within a tolerance of +/- 5mm. A laser level can be employed to verify this levelness. A level foundation surface significantly simplifies the installation of the Thermohouse courses.

For stepped foundations, the preferred step increment is 250mm. However, accommodating various step heights is possible by horizontally cutting Thermohouse elements and integrating them into the first row. This ensures flexibility while maintaining structural integrity.

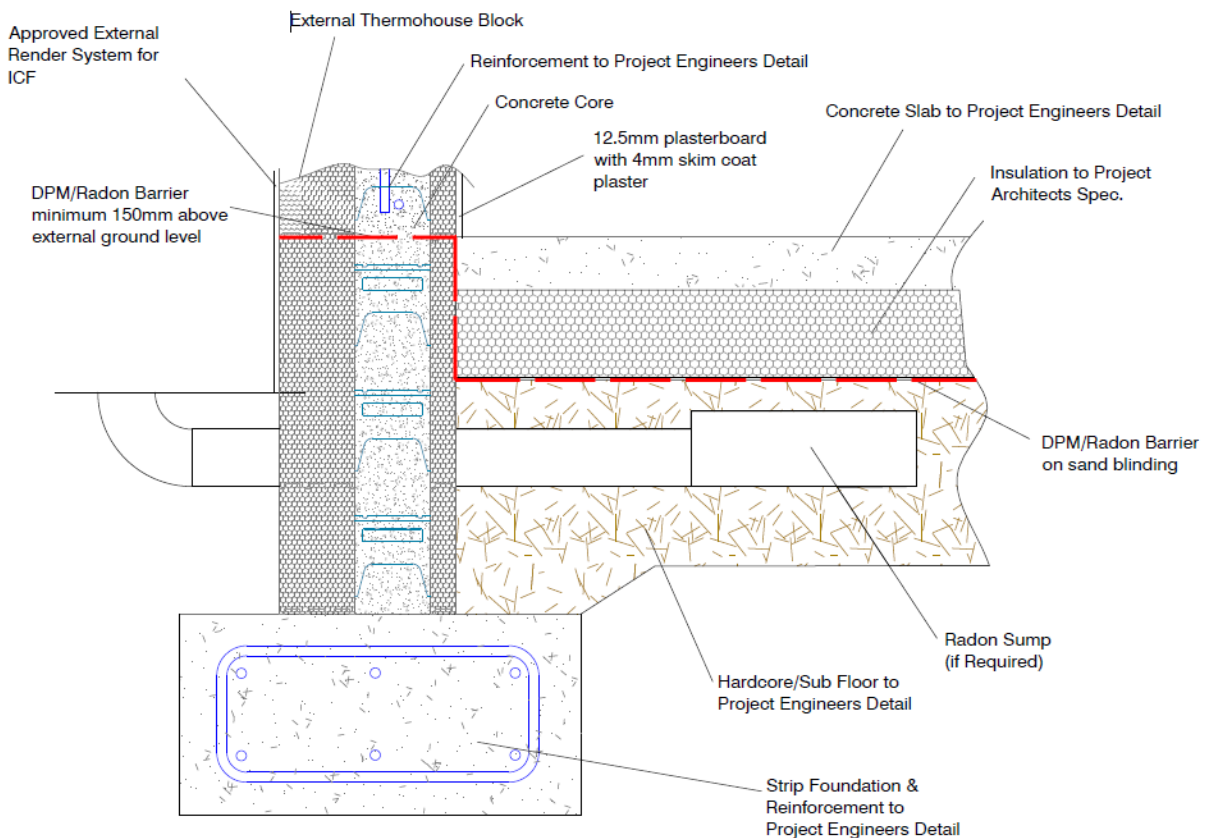

F3 - Typical Strip Foundation Detail

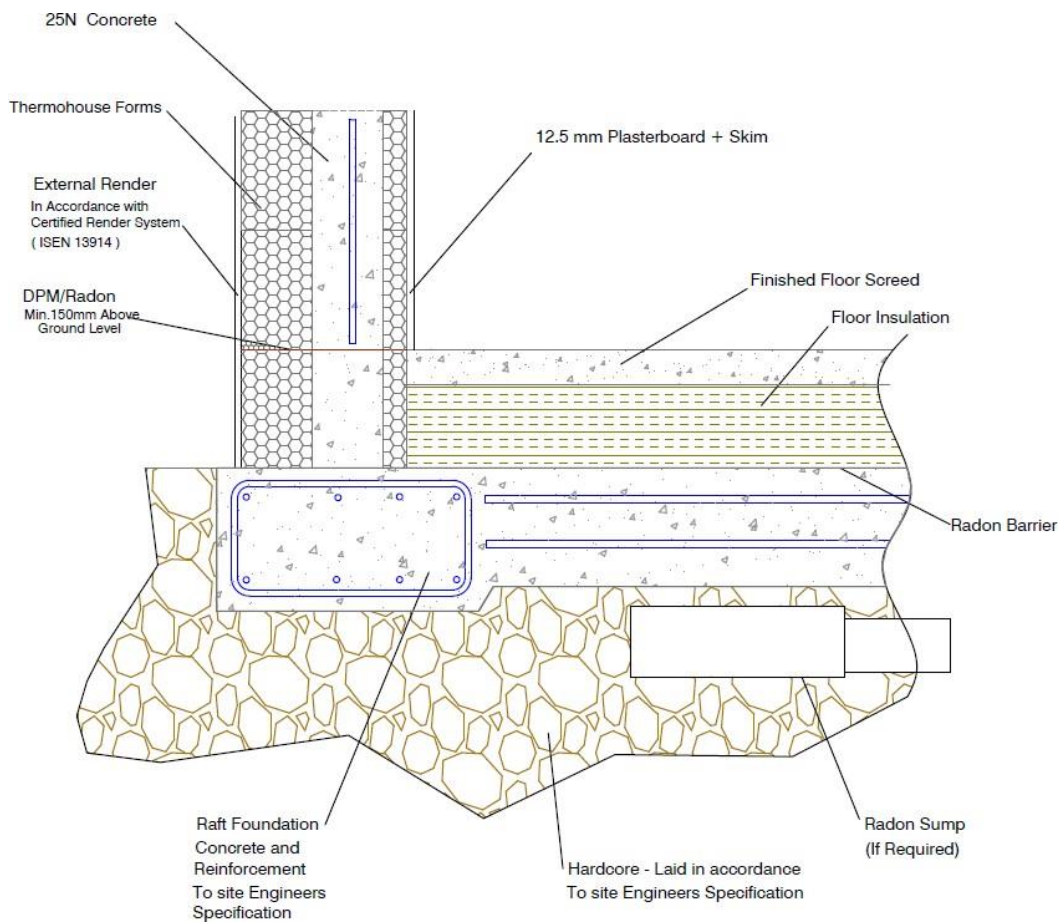

F4 Typical Raft Foundation Detail

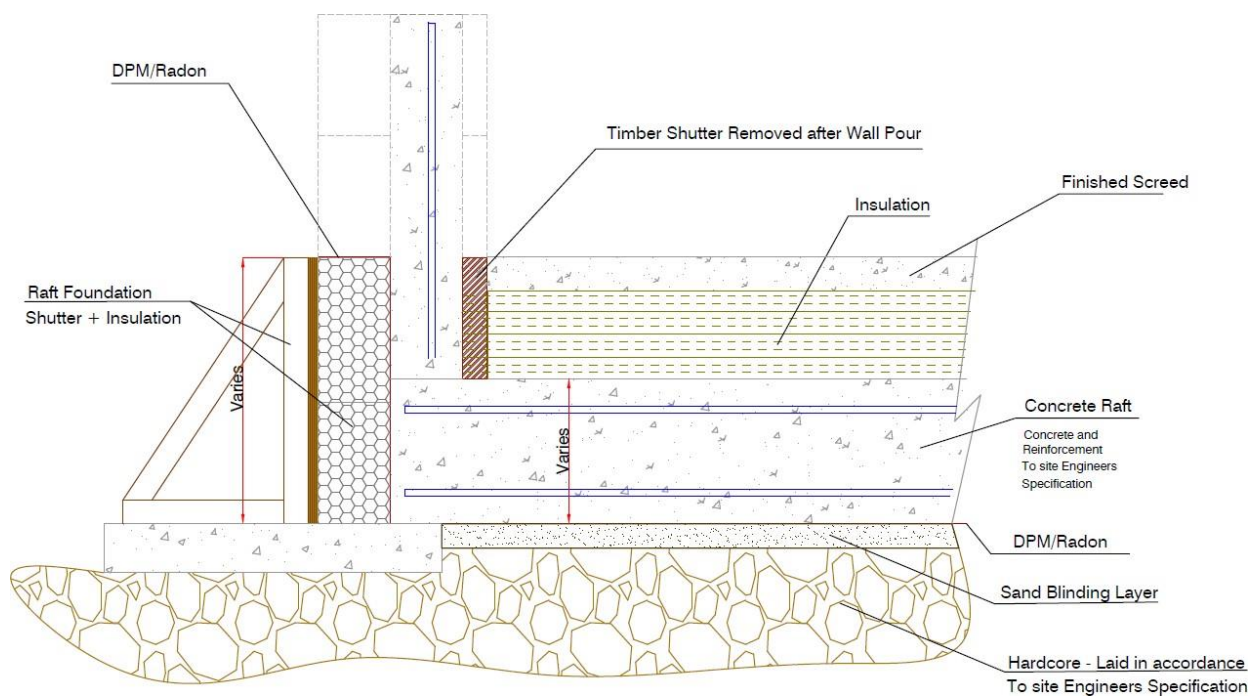

F5 Typical Raft Foundation with Perimeter Insulation

Thermohouse raft foundations have the potential to incorporate a thermal barrier along the raft's edge. To achieve this, use a TH-61 element, lining the formwork shutter up to the finished floor level. Subsequently, install the DPM/Radon barrier beneath the raft, extending up its interior, and over the top of the insulation shutter lining (TH-61).

After pouring the raft, position a temporary timber shutter to provide support for the inner insulation leaf of the initial layer of blocks. This shutter can be removed once the wall reaches the desired storey height and is filled with concrete.

Additionally, ensure that the floor insulation is installed to meet the concrete core in the wall, creating a seamless connection for optimal thermal performance.

Below images show typical raft foundation & perimeter insulation using Thermohouse.



Insulated Shutter

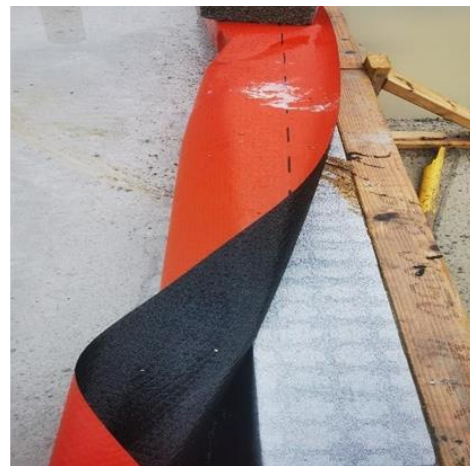

Insulated Shutter & Radon



Temporary Wall Shutter



Temporary Wall Shutter at door threshold

For the concrete pour into the walls, it's possible to block the door threshold at either end. This vacant space can be filled with structural styropor. This serves the dual purpose of providing support for the joinery and minimizing any potential cold bridging in this specific area.

Standard Wall Construction Overview

This overview provides a concise preview of wall construction, with comprehensive details and diagrams available in subsequent sections of this publication.

Step 1: Building Outline and Footing Preparation

Plan the building outline according to the specified *Thermohouse set-out* dimensions, tailored to Thermohouse formwork increments. The footprint layout is project-specific. Raise the footings to DPC level using TH-66 (open block) and TH-67L/TH-67R (corner blocks).

Place external corner blocks, alternating between TH-67L and TH-67R. TH-67L for courses 1, 3, 5, 7, etc., and TH-67R for courses 2, 4, 6, 8, etc.

Forming External Corners:

Trim 50mm from the abutment end of TH-66 to maintain vertical alignment of metal inserts within the forms.

Adjust insulation within the cavity of TH-67 corner blocks to allow free concrete flow. Lay TH-66 blocks towards the centre of each wall section.

Cut/shorten a TH-66 to finish this section. Retain the off-cut for potential use elsewhere.

Inverted Corners Construction:

Create inverted corners by overlapping TH-66 blocks, enclosing the formwork cavity (see fig. W16 page 71).

Ensure all walls are straight and level; use shims or trims if needed.

Address any inconsistencies, particularly if foundation care wasn't meticulous (aim for +/- 5mm).

Provide support and shuttering for corners, as required.

Prep for Concrete Pour:

Remove locking stubs from form tops, providing a level surface for DPM/Radon membrane at ground floor level.

Ensure all service penetrations are in place before concrete pour to avoid future core boring.

Step 2: Ground Floor Level and Wall Elevation

Moving to ground floor level, begin by inserting DPC/DPM. If constructing above a basement, the same DPC is necessary for ground floor level. Follow the previous method to raise the formwork and proceed with the next course of corner forms, starting with TH-67L followed by TH-67RR. If applicable, incorporate rebated forms TH-67RL/RR for door or window openings/reveals.

Begin with the wall that has the most door and window openings. This wall will involve the most cuts and generate off cuts, which can be utilised in various other wall areas. For door/window locations, install rebate blocks to form the closure. Complete the first course using straight blocks, either by reusing waste off cuts or by cutting to the required length.

For the second course, ensure an offset arrangement from the first course. Employ a running bond pattern of 300mm or more, allowing occasional use of 150mm infill pieces when needed. To enhance stability during the concrete pour, consider adding a horizontal straining wire along the course work (lower, centre, and upper courses)

from corner to corner, extending through external openings, this will act as additional support to stop any horizontal movement during concrete pour. It is also suggested that low expanding adhesive is used on every horizontal & vertical joint to ensure firm fix and remove any water seepage during the concrete pour.

Check for levelness across the blocks at this point. If any course is not level, use shims or trim the block as needed.

Install the horizontal anti-crack reinforcing steel in the centre of the cavity, typically on courses 2, 6, and 10, at 1.0m centres. Tie it to the metal insert for added strength.

Construct approximately 5 or 6 courses following this approach. Progress from walls with numerous openings towards those with the largest build area or fewer openings. Utilise waste cuts from corner and window formations as you proceed, particularly focusing on walls with larger build areas.

Continuously incorporate horizontal steel reinforcement where necessary, generally on courses 2, 6, and 10. Place it on top of the internal webs within the block cavity for reinforcement stability as you progress.

Installing Alignment Bracing and Window Heads

Ensure that all laid courses are level before proceeding. If there are any gaps where the bottom block meets the slab, ensure these are filled using low expansion foam ensuring all gaps are sealed to prevent seepage.

Step 3 Alignment Bracing

Propping/bracing system:

For further details on this also refer to the propping system guide section in this manual.

Install alignment bracing along the entire internal face of the structure. Position the bracing at 0.9m to 1.2m centres, maximum.

Before pouring concrete, set the intermediate braces off plumb, leaning inward by approximately 10-15mm across the full wall height. This angling helps the prop counteract the concrete's weight, maintain the wall straightness and plumb during and after pouring by adjusting the turnbuckles to suit.

The bracing also establishes a stable scaffold system with a 3 - plank configuration, facilitating the erection and concrete pouring to the walls.

Window Heads Construction: When not at course level (see detail W19 page 74)

Construct window heads using a TH61+Th20+TH-57 (50mm) horizontal insert to prevent cold bridging across the lintel.

Insert the TH-57 flush with the lower edge of internal insulation TH-20 (50mm).

Position the external insulation TH-61 (150mm) 25mm lower, creating a 25mm rebate for joinery frame fitting.

or

When cutting a standard TH-66 form for the lintel, trim metal inserts as needed to accommodate the TH-57 insertion.

Step 4 Reinforcing bar placement

For single-storey construction, build up the blocks to match the full wall height, **during** this process install a single 12mm re-bar in the centre of the cavity tied to the metal web on courses 2, 6 & 10

Once full wall height is achieved cut the vertical reinforcing steel bars to the required length and install from the top of the wall, spacing them at intervals of 1.05m.

These vertical reinforcing steel bars should be threaded through the pre-existing holes in the metal bridging plate within the blocks.

Step 5: Concrete Pouring and Compaction

Proceed with the concrete pouring process, following these guidelines for optimal results:

Concrete Slump: Maintain a concrete slump of 100-120mm for proper consistency.

Starting the Pour: Utilise a concrete pump to initiate the pour. Start at the centre of one wall and initially fill the concrete to a height of approximately 0.5 - 1.0m. in all walls (2 to 4 courses).

Continuous Pouring: Continue pouring the concrete in one direction until reaching the starting point again. Repeat this process for every subsequent meter of wall height.

Vibrating the Concrete: Employ a slender concrete vibrator, preferably with a maximum 37mm poker, using min. vibration of the concrete eliminate any air pockets, thus preventing honeycombing within the wall, and ensures complete compaction of the concrete, avoid placing the poker into the corners or the joints of adjoining walls.

By adhering to these steps, you'll achieve a successful concrete pour that guarantees structural integrity, excellent air-tightness and long-lasting performance.

Step 6 Levelling off

Level the concrete until it's flush with the top block. If needed, insert anchor bolts during this stage. These bolts can serve for wall plate installation, if necessary.

Step 7: Removing Bracing and Continuing Construction

Once the concrete has fully cured, take the following actions:

Remove the alignment bracing that was installed earlier. With the bracing removed, you can now move forward with the next stages of your construction process.

By following these guidelines, you ensure proper alignment and thermal performance in your construction project.

Wall Layout

1. Determine Wall Height and Element Placement:

Before commencing the initial layer of elements, ascertain the precise wall height needed for your project. The Thermohouse elements stand at a height of 250mm/course. If your story height isn't evenly divisible by 250mm, you have the choice to horizontally trim either the first or last element course.



Base Rail



Rising Walls



Radon Barrier



Service Penetrations

2. Verify Thermohouse Layout and Incremental Placement:

It's advisable to reconfirm the accuracy of the *Thermohouse layout* prior to setting the first block course. Arrange the layout in 150mm increments.

3. Block Placement Guidelines:

- Position blocks with the protruding interlock facing upwards.
- Always initiate placement from one corner to another corner or Door/window ope.
- For above-ground levels, utilise end/corner blocks TH – 67L / 67R as depicted in Figure W1.
- When possible, always start the first course with TH – 67L for all external corners, progressing in a clockwise direction. For courses 3, 5, 7, 9, and so forth, continue using TH67L.

- Similarly, for the second course, begin with TH – 67R for all external corners in an anti-clockwise manner. Use TH – 67R for courses 4, 6, 8, 10, etc.....
- Modify block ends as indicated in Figure W1 & W16 or extract sections within the cavity to facilitate concrete flow between adjoining elements.
- Construct internal/inverted corners utilizing TH-66 (open blocks), trimming the external insulation shorter than the internal side for overlapping on alternating courses, thereby enabling full concrete penetration at corners.
- Keep placing straight blocks (TH-66) along the wall length.

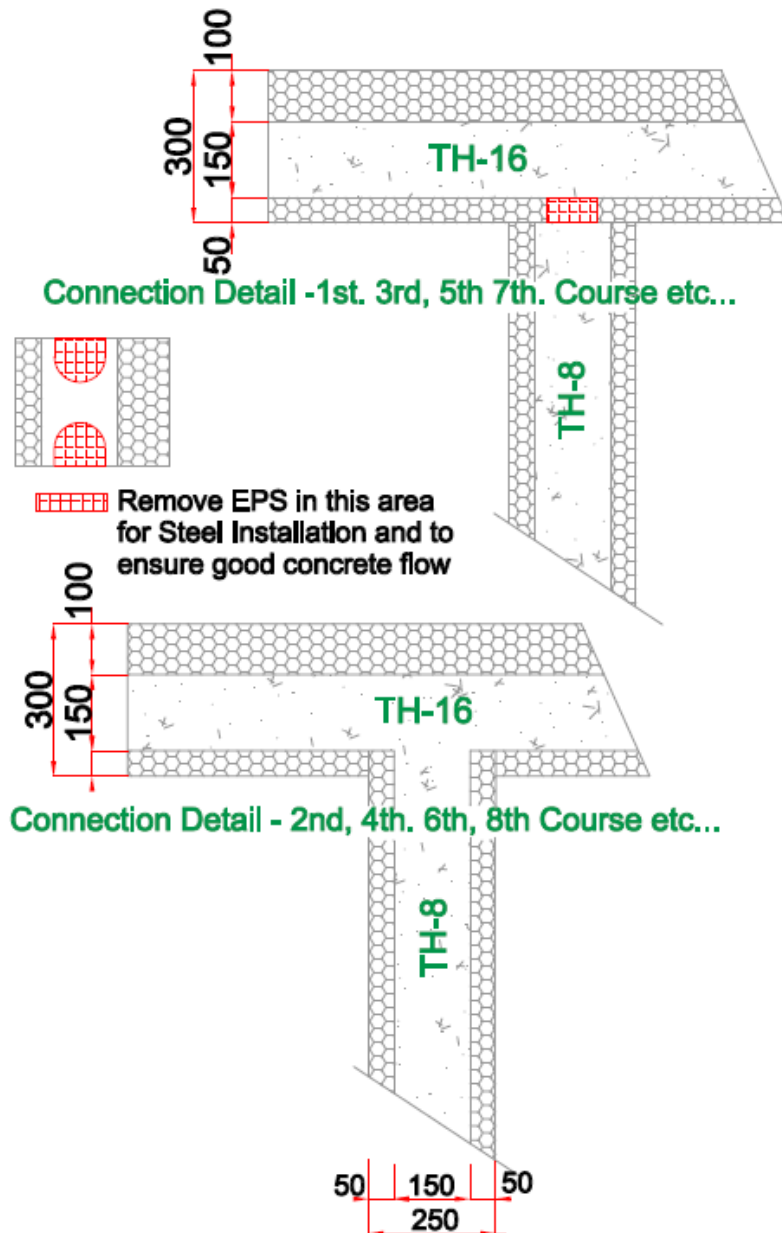

W5 - Typical Detail Showing Internal Load Bearing Wall Abutting to External Wall

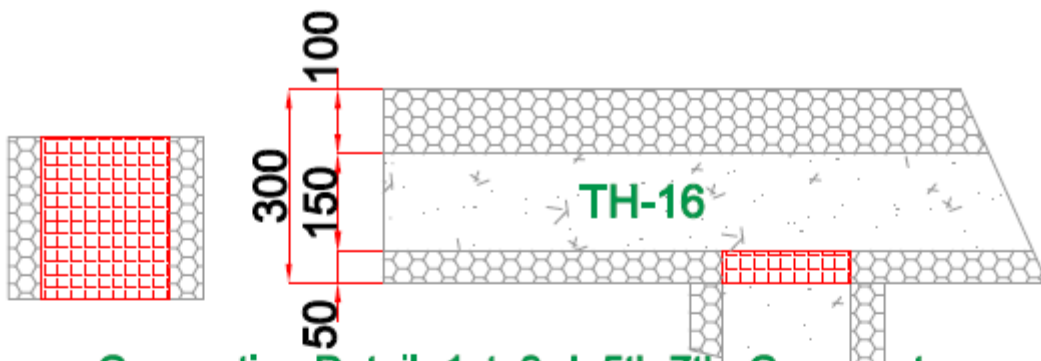

Connection Detail - 1st. 3rd. 5th 7th. Course etc...

 Remove EPS in this area to Comply with fire Regulations also for Steel Installation and to ensure good concrete flow



Connection Detail - 2nd, 4th, 6th, 8th Course etc...

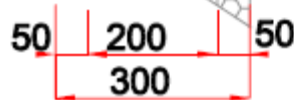

W6 - Typical Detail Showing Party Wall Abutting to External Wall

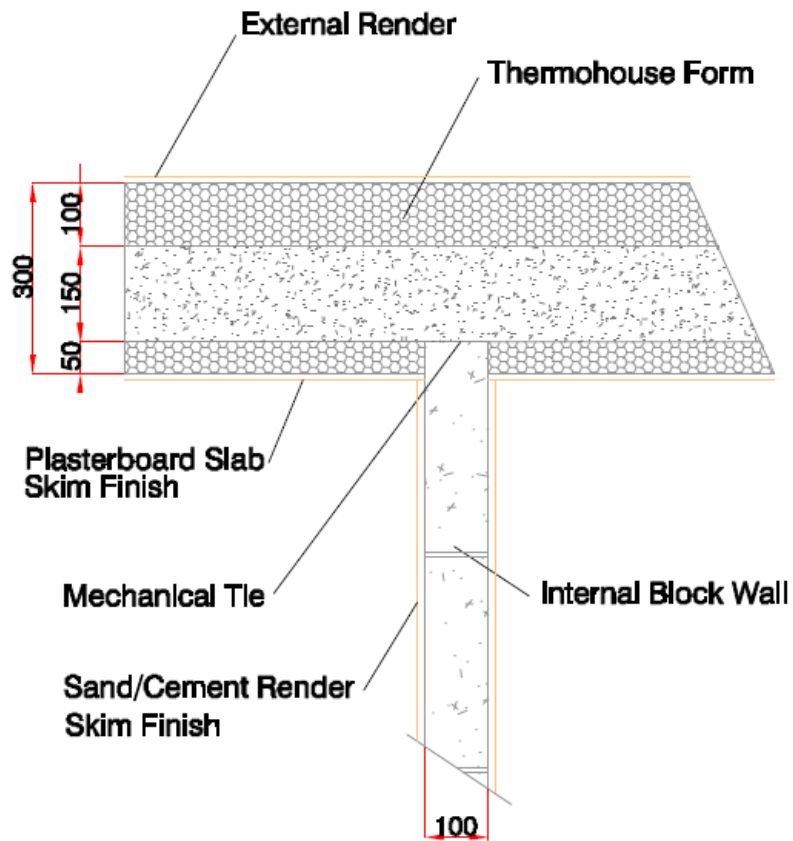

W7 - Typical Detail Showing Internal Block Wall Abutting to External ICF Wall

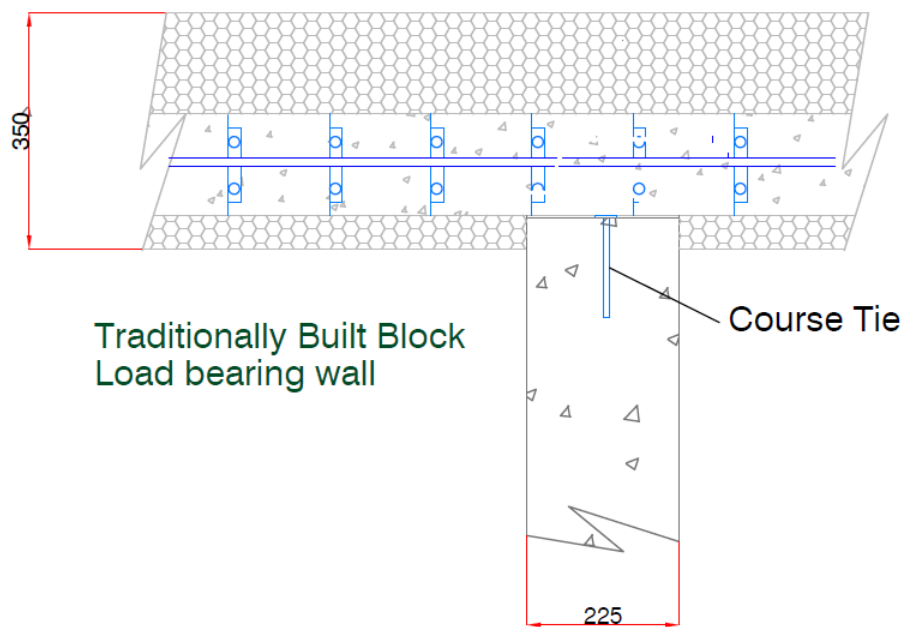

W14 - Typical Detail Showing Internal Load Bearing Block Wall Abutting to External ICF Wall

4. Managing Openings and Corners:

- As the blocks approach a door or window opening, locate a rebate block (Th67RR/RL), if suitable cut the rebate block to suit wall length
- Or cut a standard open block TH - 16 to fit the space between the rebate block and the preceding one.
- Bring the second course with the first starting with a TH – 67R end block in the corner, and adapt block sections as shown in Figure W1.
- Maintain the same approach around the wall until the second course is complete and dimensions are validated.

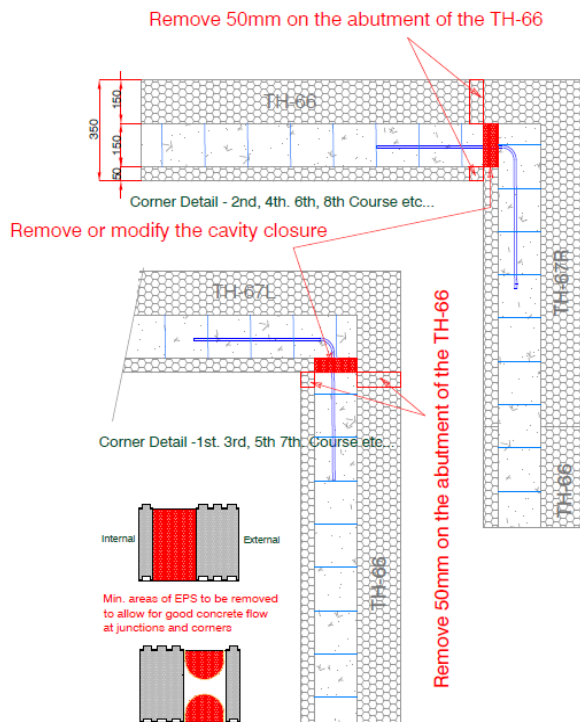

**W1 – End Block Corner Assembly
- Standard Corner**

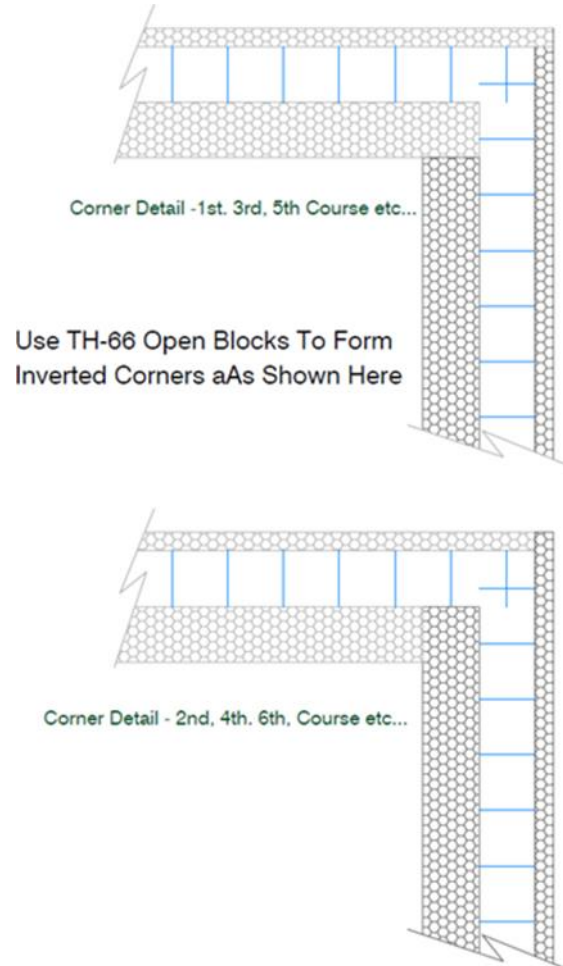

**W16 – End Block Corner
Assembly Inverted Corner**

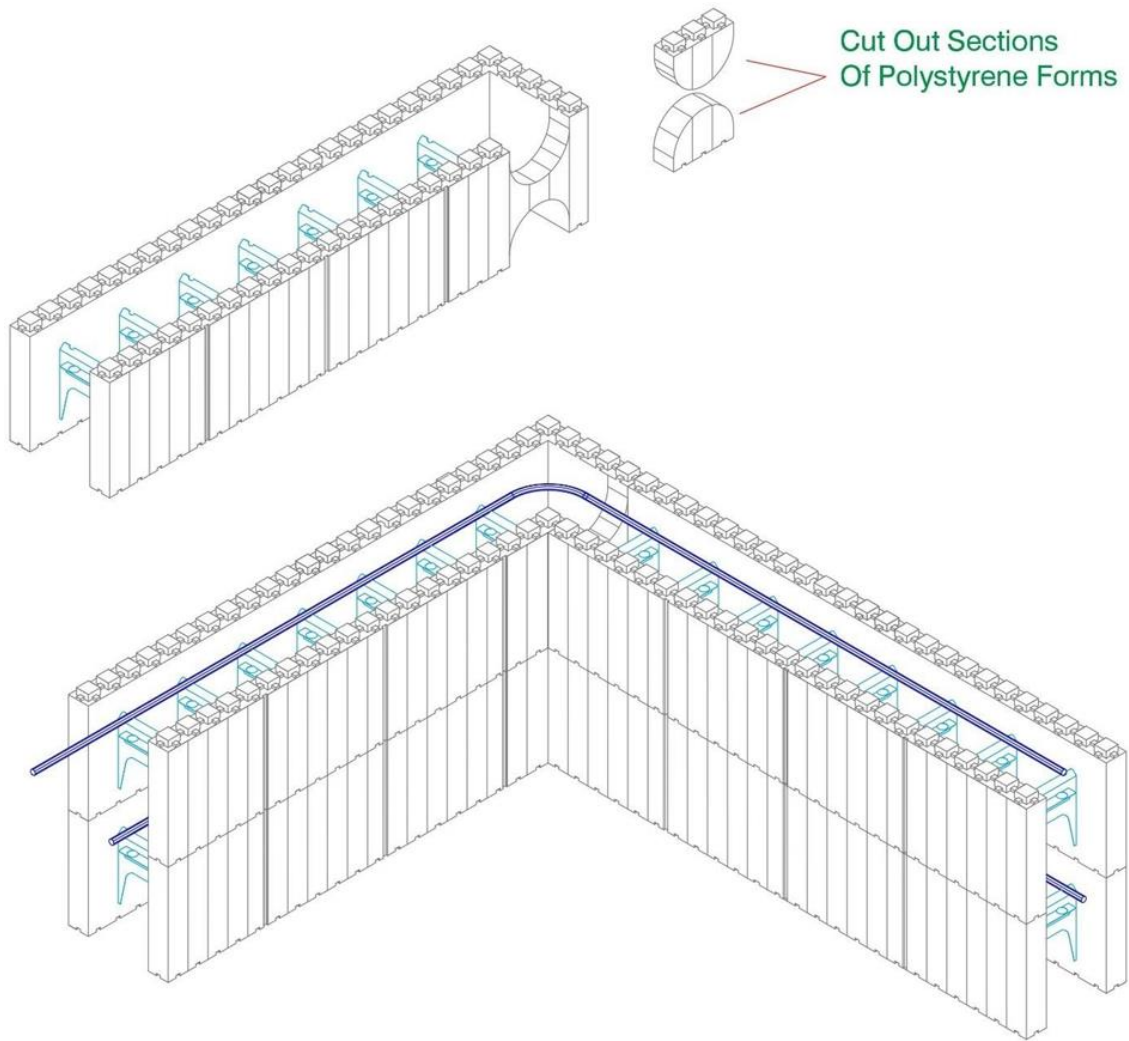

W26 - 90° Internal Wall Corner Assembly
Alternate end block on every course

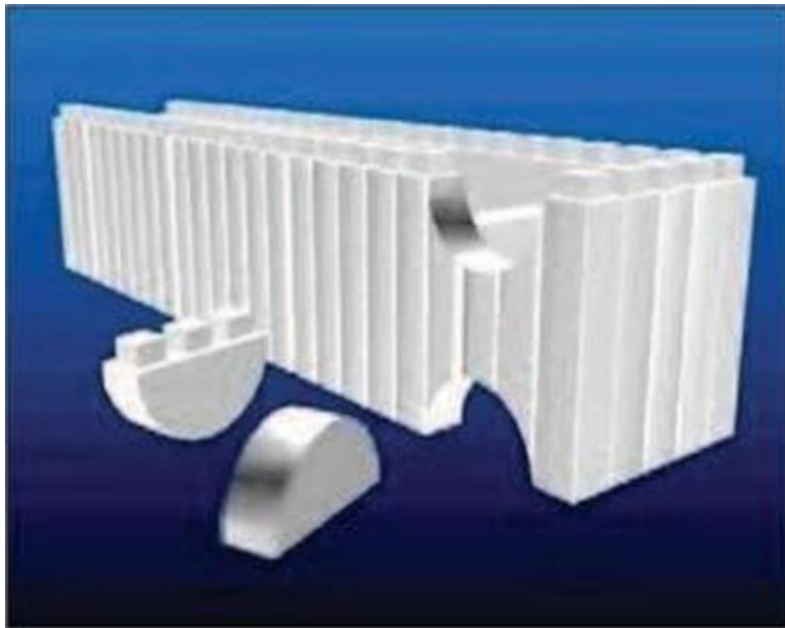

Typical Minimum Cut-Out in Corners

In basement construction and on party walls, the EPS crossing the cavity **MUST** be completely removed.



Typical Corner Detail

Showing the installation of a double layer of reinforcing bar where necessary, generally a single layer is sufficient, this should be clarified by the project engineer.

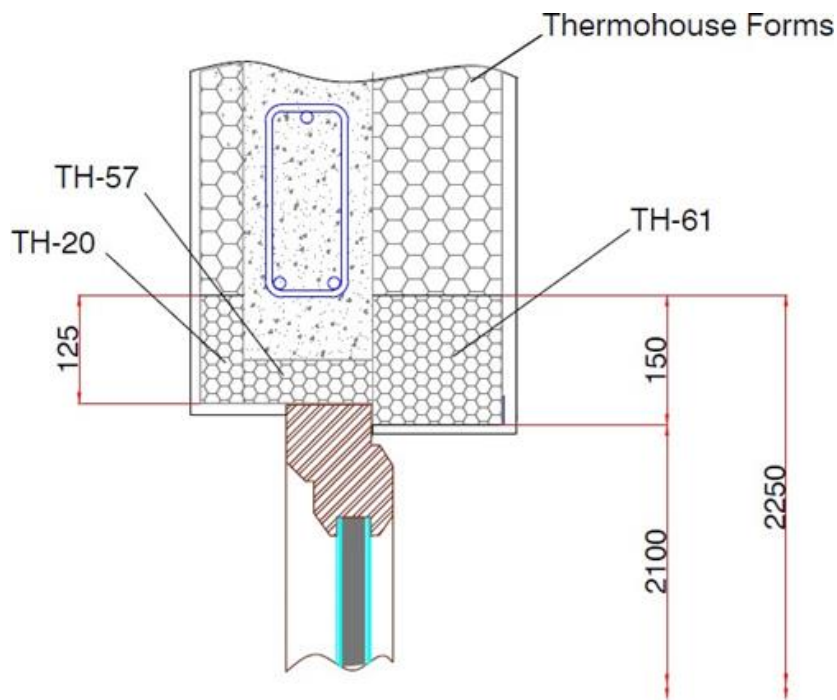

W19 Figure 2c – Window Head

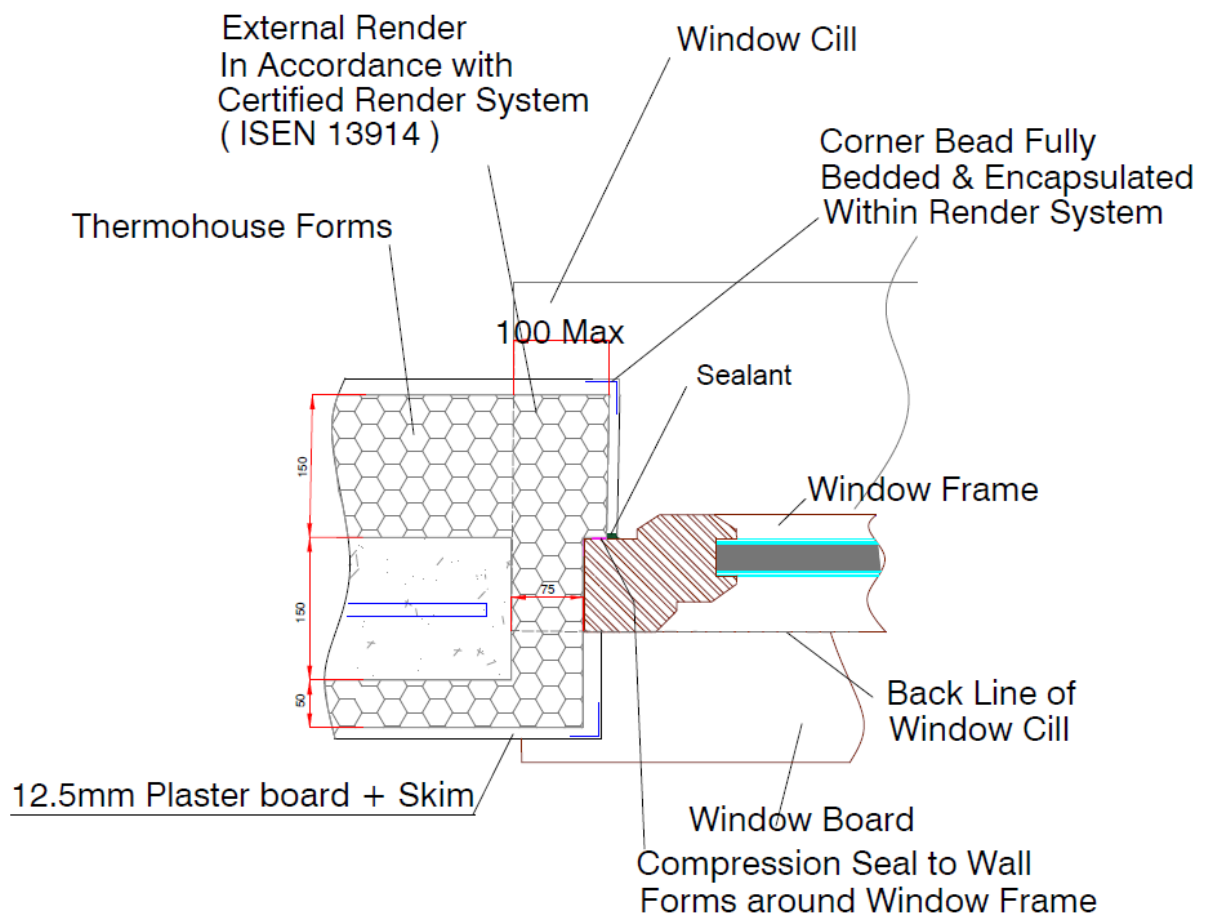

W21 TH-013 Figure 3 (Plan view)- Rebate block at window/door opening

5.Maintaining Bond and Insert Alignment:

- Trim 50mm off the abutment end of the TH-66 and securely place the open block against the initial corner block to eliminate gaps. Alternating corner block types between courses establishes a 300mm running bond.
- Continue with the second course similar to the first, ensuring the minimum 300mm running bond between courses.
- Once about 6 full courses and the ground floor window/door opens are formed, assess wall and corner alignment for plumbness and levelness.

6.Wall Support and Levelling:

- Attach support frames to walls at intervals of 900/1050mm (maximum 1200mm). If a wall level discrepancy exceeds +/- 5mm, rectify it by shimming low spots or trimming high ones.
- Verify that all blocks are level and aligned according to the overall layout. Seal any gaps along the base joint to the floor and any wall damage with a low expansion foam to avoid concrete seepage during the pour. Allow ample time for setting.

7.Subsequent Block Installation:

- Installing subsequent block courses follows the same procedure. The following rules must be consistently followed:
 - 7.1. Start from a wall corner, trimming 50mm from the TH-66 abutment end, and proceed along the building's external line.
 - 7.2. Maintain the running bond pattern between alternate courses.
 - 7.3. Place horizontal steel reinforcement, as directed by the Supervising Engineer, generally on courses 2, 6, and 10.

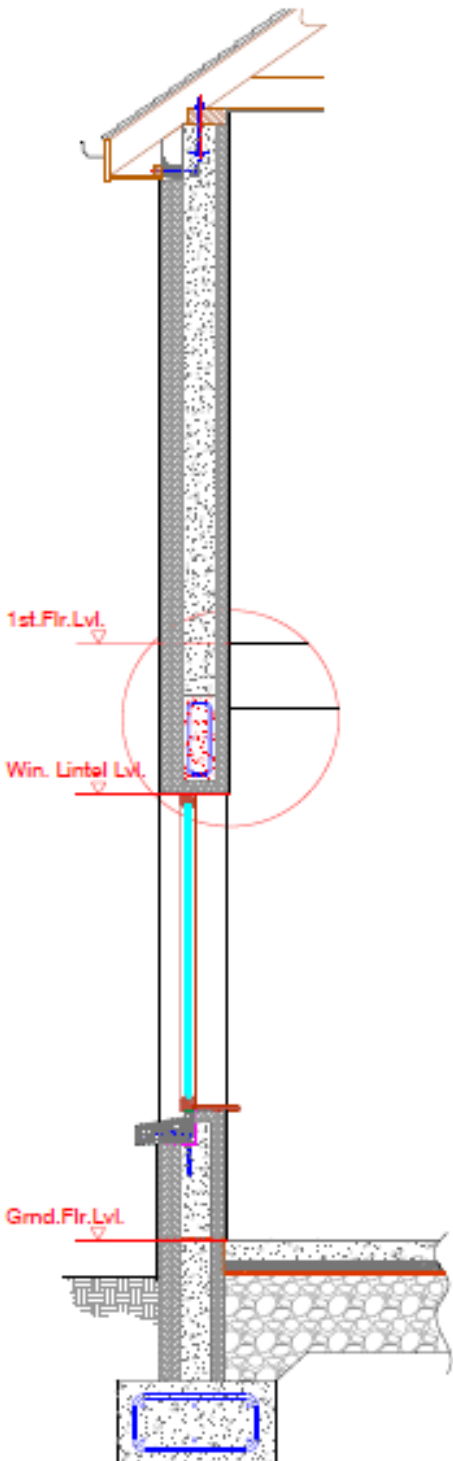

Option 1 - External Wall Supporting Thermofloor Concrete Internal Floors

Design Assumptions:

Permanent Loading:
 Thermofloor TH21 Flooring with a Minimum Concrete Depth of 100mm Spanning 5m
 Roof with Maximum Span of 8m

Variable Loading:
 First Floor - 2.5kN/m²
 Roof - 0.6 kN/m²

Concrete:
 Concrete Mix Design to be C25/30

Option 1.		250mm Concrete Floor			
Clear Span	1.0m	2.0m	3.0m	4.0m	
Member Size	200mm Deep x150mm Wide	400mm Deep x150mm Wide	400mm Deep x150mm Wide	400mm Deep x150mm Wide	
Tension Reinf. Required	2 no. 12mm	2 no. 12mm	2 no. 16mm	4 no. 16mm	
Shear Links	6mm @ 100 Centres	8mm @ 200 Centres	8mm @ 200 Centres	8mm @ 200 Centres	

Option 2 - External Wall Supporting Timber Internal Floors

Design Assumptions:

Permanent Loading:
 Timber Flooring Spanning 5m
 Roof with Maximum Span of 8m

Variable Loading:
 First Floor - 2.5kN/m²
 Roof - 0.6 kN/m²

Concrete:
 Concrete Mix Design to be C25/30

Option 2.		Timber Floor			
Clear Span	1.0m	2.0m	3.0m	4.0m	
Member Size	300mm Deep x150mm Wide	400mm Deep x150mm Wide	400mm Deep x150mm Wide	400mm Deep x150mm Wide	
Tension Reinf. Required	2 no. 12mm	2 no. 12mm	2 no. 16mm	4 no. 16mm	
Shear Links	6mm @ 100 Centres	8mm @ 200 Centres	8mm @ 200 Centres	8mm @ 200 Centres	

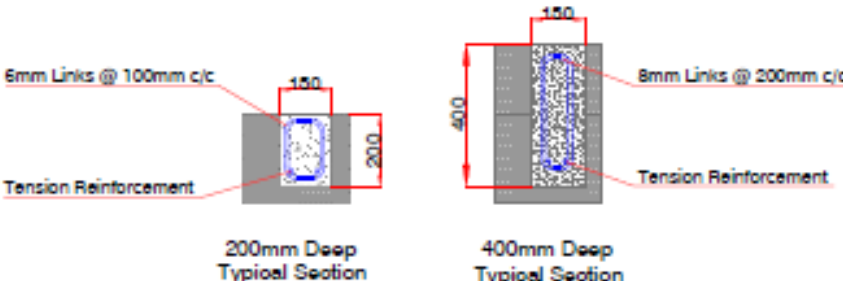

TITLE:

Typical Concrete Lintel Specifications to IS EN 1992-1-1

Coolcasslagh Kilmaley Co. Kerry Ireland Tel: 064 66 31307 Email: info@thermohouse.ie Web: www.thermohouse.ie	This drawing to be read in conjunction with all other CMCE drawings and any other relevant information. No dimensions are to be scaled from this drawing. Unless noted otherwise, all dimensions are in millimeters and all levels are in meters from the noted datum. Copyright reserved.	DATE: 23 April 2015
	DRG. NO. LD/1	REV. A
	SCALES: Not to Scale	
	ENGINEER: D. Tarrant	

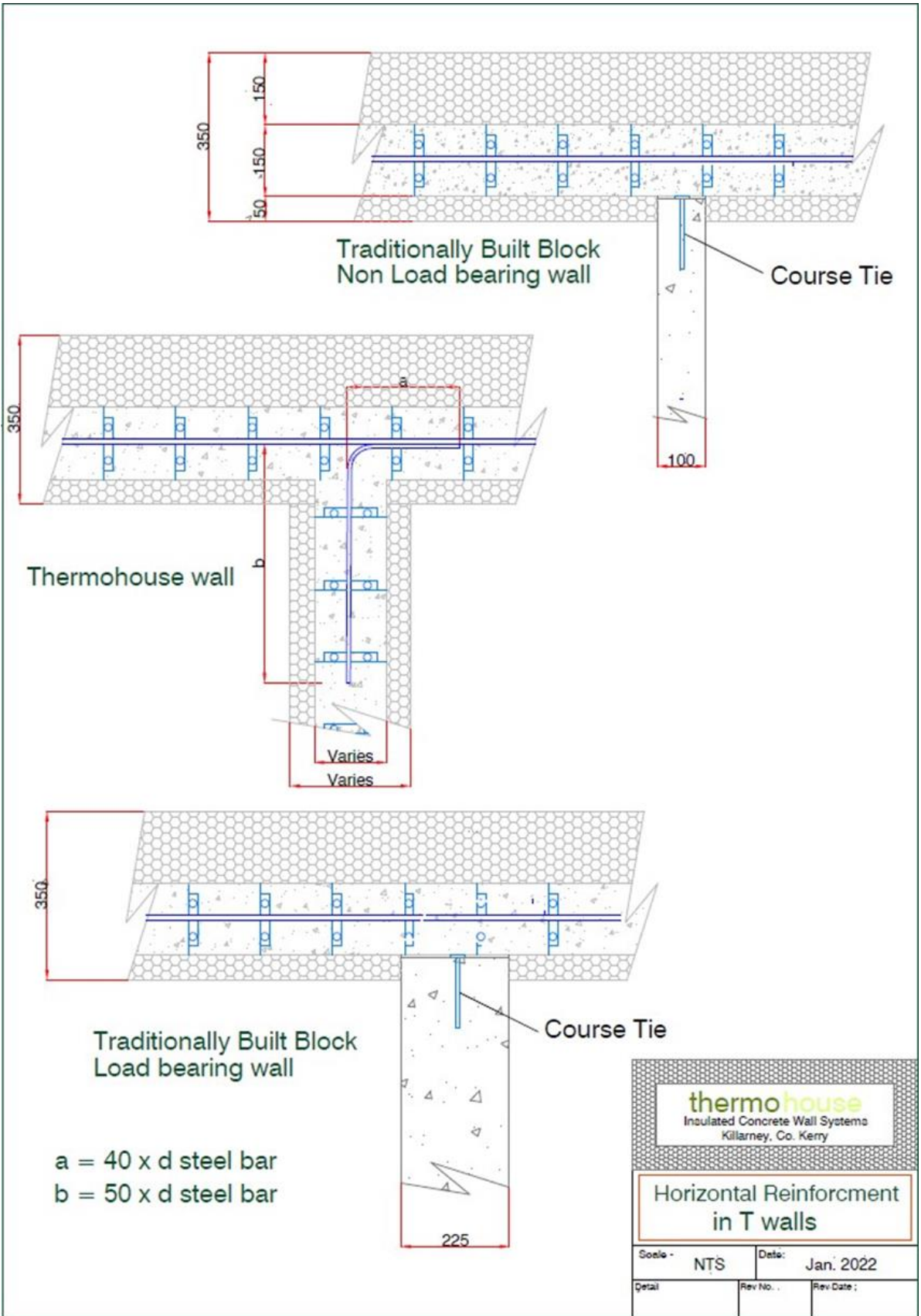

W27 - Connecting traditional block walls to ICF junction

Party walls & Firestopping

Thermohouse offers the Party Wall Block as an excellent solution for establishing party walls. This option proves particularly advantageous when constructing apartments, semi-detached homes, or terraced properties where adherence to building regulations necessitates a party wall. Our party wall block satisfies all stipulated building regulations, and it has undergone rigorous testing to successfully meet acoustic requirements.

In the below diagrams, we will delve into the specifics of constructing party wall junctions and implementing fire stopping measures within party and external walls. These guidelines ensure the proper assembly and compliance with relevant regulations for this critical structural element.

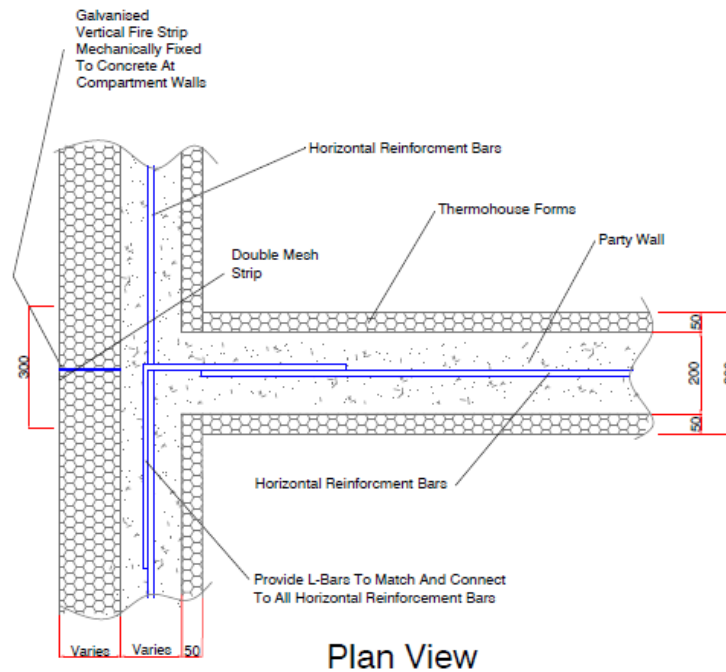

W4 Figure 7 – Typical 300mm Party Wall to External Wall Detail

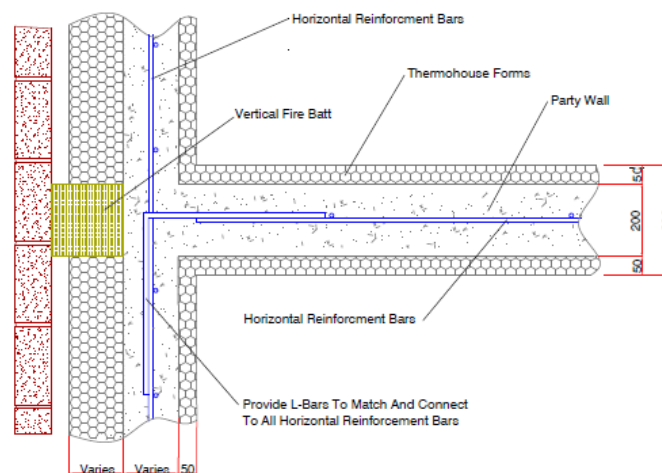

W2 Figure 7a – Typical 300mm Party Wall to External Wall Detail with Brick Skin

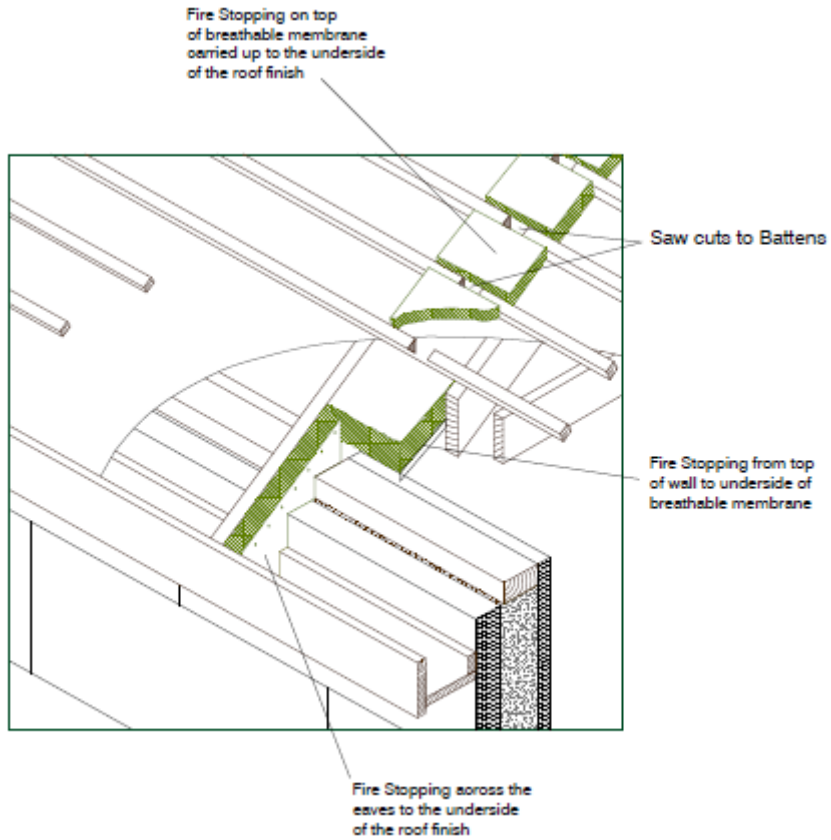

W3 - Firestopping on Party Wall Detail

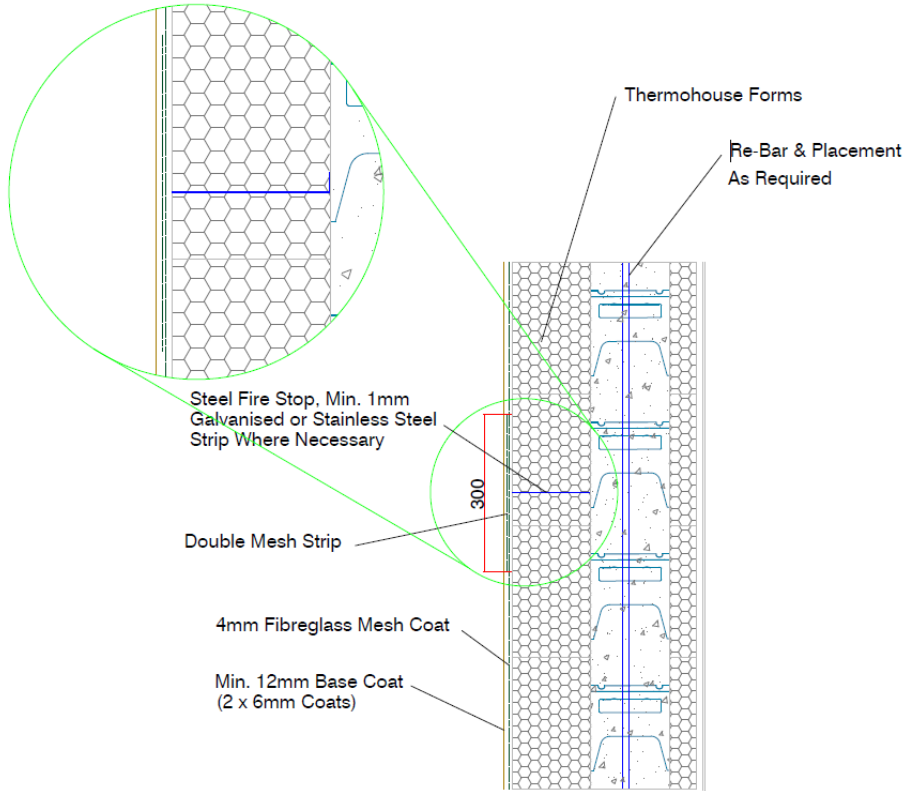

W30 - Firestop Detail

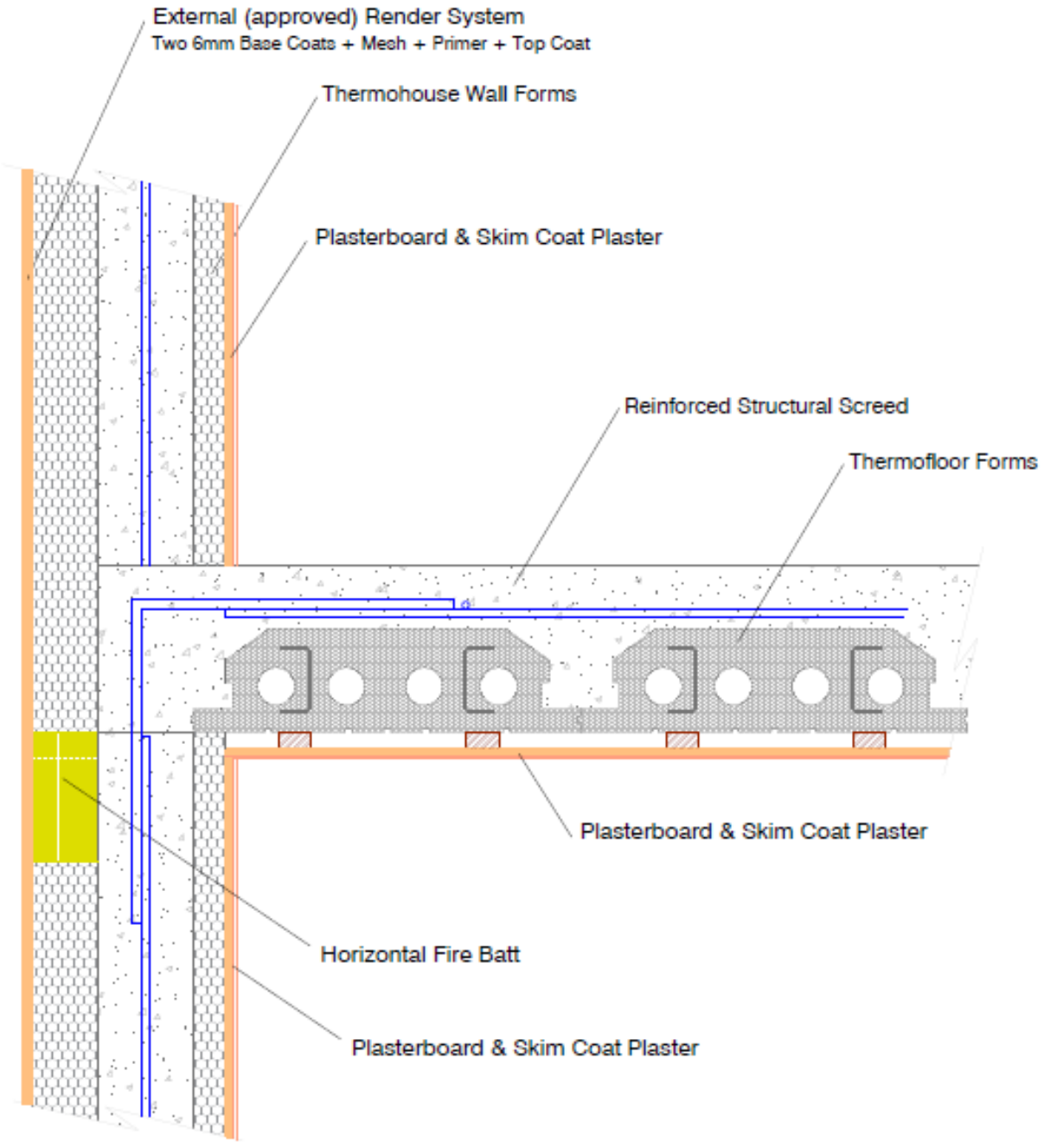

W8 - Typical Horizontal Fire Stop at Floor Level Detail



External Curved Wall Construction Photo



Dormer Window & Arched Window Photo



Long Span Window Photo



Wrapping a structural steel Photo



Commercial Building – Showing Previous Structural Column Encased in Wall photo



Single Concrete Pour To Full Wall Height - Floor To Ridge Level At 6.0m photo



Typical Concrete Pour photo



Design showing the versatility of the system photo



Corner window versatility photo



Designs showing the versatility of the system



Double Basement Walls



Wall Alignment System / Propping System Guide

Order Placing

When placing an order for the support props with Thermohouse: To ensure a smooth and efficient delivery process, it is important that we have the following information from you in advance:

- The exact number of props you require for your project Generally one/(lin. m).
- The preferred delivery date to your site, including the specific time frame for delivery.
- The duration for which you will require the support props on site.
- The date and time when you will need the support props to be collected.
- Information on whether you will have a forklift available on site to assist with unloading.
- Details on the type of vehicle that will have access to your site, as well as the dimensions of the access route.
- Information on whether there will be adequate unloading space available at your site.

Please note that we require a minimum of 2 weeks notice in advance to arrange the delivery of the required props. This advance notice will allow us to ensure that everything is in place for a seamless delivery process.

Delivery Day

The delivery process will be carried out according to the information that was provided during the order placement phase, as previously agreed. The vehicles will be loaded with stillages that contain the Support Props. Each stillage is capable of holding 20 support props and these will be placed onto the lorry in either a single or double stacked configuration, based on the number of props ordered and the type of vehicle being used.

To ensure efficient and safe unloading, it is important that you have access to mechanical offloading equipment at your site. This will help to minimize the amount of time required for unloading and to ensure that it is done in a secure and safe manner. The driver will provide a delivery note for you to check and sign, upon arrival at the site. The site is responsible for ensuring that there is safe access, adequate unloading space, and proper unloading procedures in place for the props. If the driver deems the unloading conditions to be unsafe, they have the right to leave without unloading the props.



Loading – 19 Vertically & one on top horizontally

Collection Day

Upon collection, site must have all the Support props stored safely into the storage stillages with 20 props per stillage as they were delivered (see above).

The filled stillages should then be stored safely on site where the vehicle can be safely loaded. Site must assist the driver in safe loading of all the equipment, using mechanical loading.

All damages or missing props must be notified at this stage, which will be charged as per the Equipment Hire Agreement.

Support Prop User Guide

It is essential that all health and safety (H&S) requirements are followed in accordance with local guidelines. Each site must create its own method statements and risk assessments tailored to their specific circumstances. After conducting their own H&S checks to ensure the suitability and safe use of the support prop system, they should use the provided guidance for proper installation and best practices.

1. A wall alignment system is used to keep the wall straight and plumb during concrete placement. Typically, the wall alignment system is installed on the inner side of the Thermohouse system. Each alignment unit consists of a base rail, vertical steel upright, a turnbuckle arm and a scaffold bracket. Corner props are available, these do not provide for scaffold support and are positioned after the standard prop is located to suit (see fig. 4 Below). Details and certification of the alignment system are shown in pages 93 - 95
2. After installing 3 to 6 courses of Thermohouse blocks and ensuring that the courses are perfectly level and square (unless the design dictates otherwise), place the alignment system along the walls to prepare for fixing.
3. Install the alignment props around the entire internal face of the structure no more than 600mm from each corner or end wall and at 0.90 to 1.05 centres (1.2m max)., Fix the props to the Thermowall blocks using a 6x100mm screw into the metal insert, align and position the corners and fix these props to the concrete base , all intermediate props can then be lined and fixed in relation to these. When plumbing the walls in preparation for the concrete pour it is advisable to set all the props on the corners perfectly plumb and the intermediate props in between on a very slight incline inwards by approx. 10 to 15mm on the wall height, adjustment can be made during/after the concrete pour as necessary, this will allow the prop to push out against the weight of the concrete ensuring that the walls are straight and plumb during/after the pour.



Fig. 1



Fig. 2

4. When using the special corner prop, position the first standard prop 300mm from the corner and another beside it (see Fig.1) at 600mm centres.
5. Attach the uprights (See Fig.5) to the blocks by use of 5/6mm diameter 100mm long screw into the metal flanges which are positioned at 150mm centres (25mm inset from the face) all along the wall. Alternatively if necessary, fix to a plywood block placed inside the ICF cavity of the formwork as you rise the courses, this will require a screw length of 120mm.
6. Position the special corner prop within 600mm of the corner and clamp it over the two previous props at 90 degrees. Fix the standard props with a minimum of two 10/12mm fixings at least 80mm long fixed diagonally opposite (see Fig. 3). The special corner prop sits on the standard prop and should be fixed down with at least one 10/12 mm fixing 180mm in length or as shown (See Fig. 4).



Fig. 3



Fig. 4

7. Alignment units should also be placed within 300/600mm on either side of every door and window opening and along the lintels of large openings to maintain the alignment of the wall.

8. Again, ensuring that the courses are level, fix the alignment units securely to the floor preferably with 10/12mm concrete bolts or expanding metal anchor bolts (see Fig.3).



Fig. 5

9. Ensure blocks are straight, plumb and properly aligned along each wall length. If necessary, provide external support against wind and other lateral loads until concrete is poured and gains enough strength.
10. If the alignment system is to be used as a working platform; Place the appropriate scaffolding planks three wide, (see Fig.6) to form a level working platform, install the uprights for the guardrail supports into the receivers on the props and secure in place (see Fig.7).



Fig. 6



Fig. 7

11. Continue with the addition of a handrail and knee guard, both to be at regulation height (see Fig.8)



Fig. 8

Install a toe board, fixed to the guardrail uprights, providing a safe working platform according to current safety regulations (See Fig.9 & 10).



Fig. 9

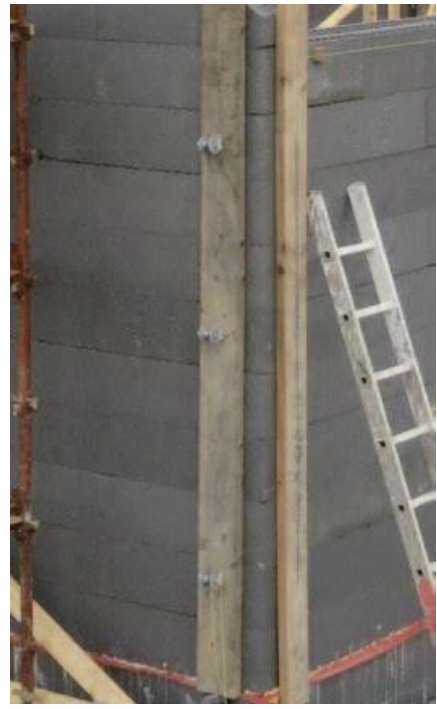

Fig. 10

12. Heads and reveals, of the window and door openings, will require support during the pouring of the concrete.
13. Before, during and after concrete placement, the diagonal turnbuckle arm is used to adjust wall straightness and assure that all walls remain plumb.
14. Overall tolerances for the building must comply with BS 5606 Guide to accuracy in building.
15. Remove bracing after the concrete has cured and proceed with further stages of construction.



Fig 11. Wall alignment props



Structural Certificate

October 13, 2016

- Component:** Thermohouse Prop/Platform System.
- Test:** Tested by an independent test house to a specification provided by S-Mech Ltd, against the distributed load and edge protection requirements of requirements of BS EN 12811-1:2003, and the Class A Edge Protection loading requirement of BS EN 13374:2013
- Results:** The component is compliant with the requirements of the above Codes, with a safe working distributed load capacity of 2.0 kN/m².

Certified By:

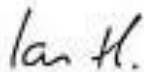

Ian R Hale. BSc (Hons) MSc CEng MStructE
for S-Mech Ltd.

Registered Office: 4 Babylon Lane, Chorley, Lancashire, PR6 9NN. Registration No. 06029673

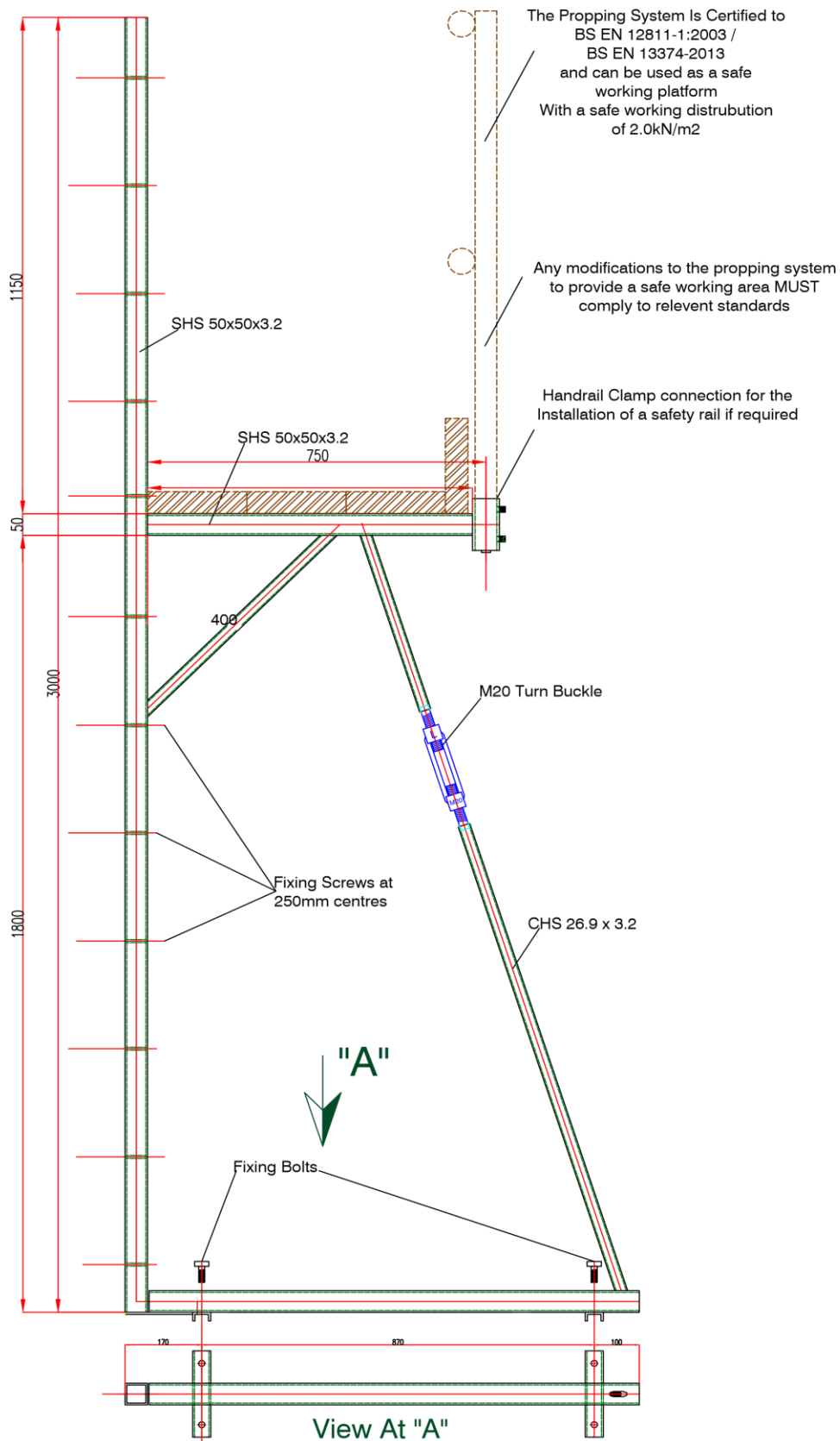

W15 - 3.0m Wall Support & Scaffold Support Details

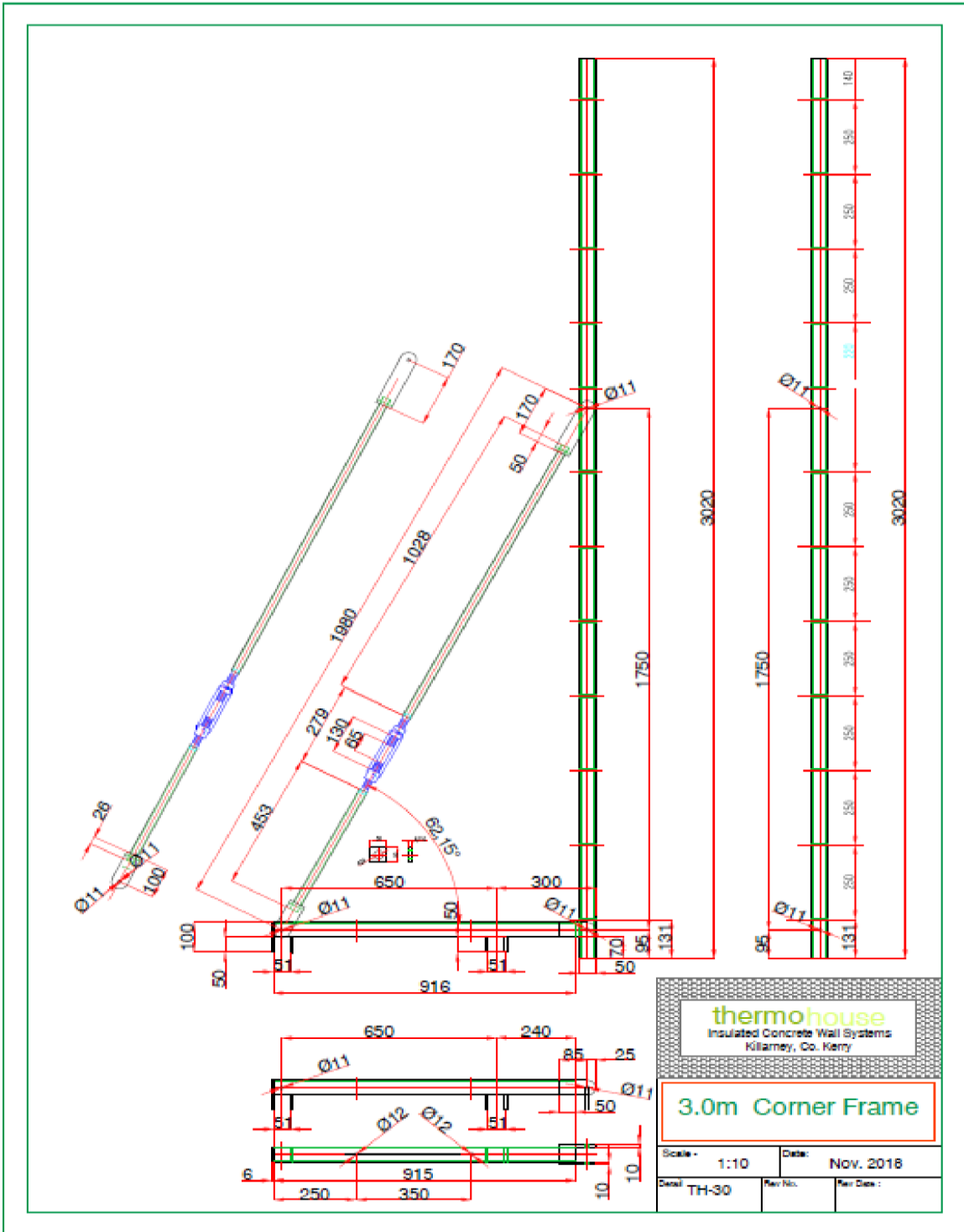

W15b - 3.0m Corner Wall Support Details

Reinforcement

The specific reinforcement quantities, size and placement details need to be confirmed by the Supervising Engineer.

The minimum required steel amounts are outlined in the diagram and photo's below. If reinforcement is needed primarily for controlling cracks rather than structural purposes, the option of using fibre-reinforced concrete with the appropriate consistency could be considered.

Reinforcing steel enhances the strength of concrete walls, reducing the risk of cracking and deformation under various loads like backfill pressure, wind forces, and other stresses. Additionally, it aids in managing cracks arising from temperature variations and shrinkage.

For reinforcement in Thermohouse walls, a non-contact splice is typically preferred, except for heavily reinforced walls. The standard minimum concrete cover for reinforcement is usually 30mm, though consultation with the Supervising Engineer is recommended.

It's the installer's responsibility to ensure that reinforcement specifications align with prevailing building regulations.

When incorporating reinforcement, if necessary, follow this method:

Construct the wall as previously instructed, placing horizontal reinforcement as required. As each required course is laid, incorporate appropriately sized horizontal reinforcement into the wall. The design of Thermohouse webs secures the reinforcement in a staggered manner, with each bar slightly offset from those above and below.

Maintain the correct overlap splice length, either 50 times the bar diameter (50d) or 600mm, choosing the greater value ($d = \text{bar diameter}$). Adhere to this specification or any other provided by the Supervising Engineer when positioning horizontal reinforcement.

After all blocks are in position and erected to the pouring height, introduce the vertical reinforcement. Lower the vertical bars into place at intervals of 1050mm from the wall's top, threading them through the steel bridges on each block.

Utilise plastic or steel wire ties to secure each vertical bar to the uppermost row of horizontal reinforcement.

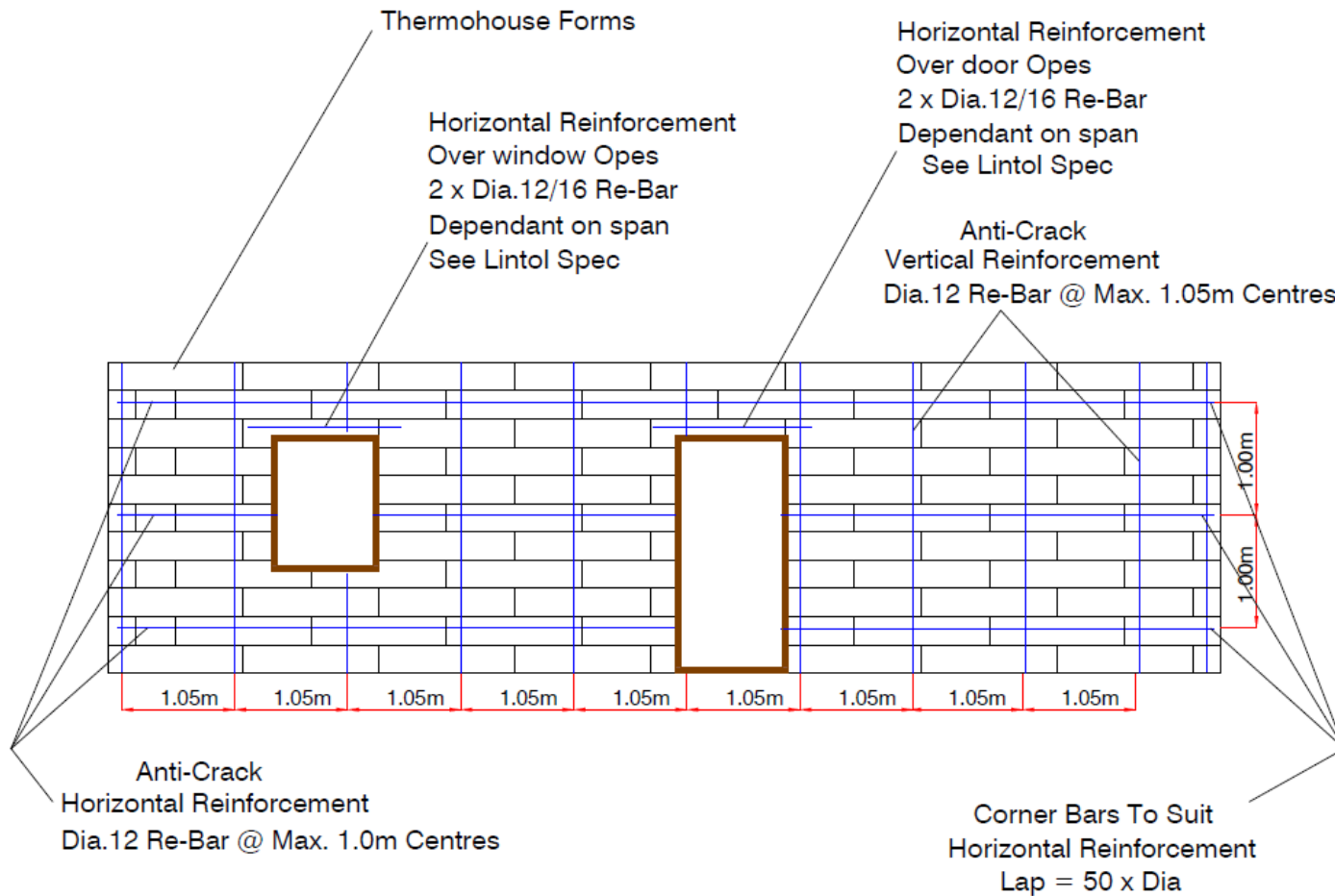

W12 - Reinforcing Steel Design



Lintel Steel Reinforcement
(incorporating flooring mesh)



Steel Reinforcement in forms



Reinforcement in Corner Section



Reinforcement & Lintel Section

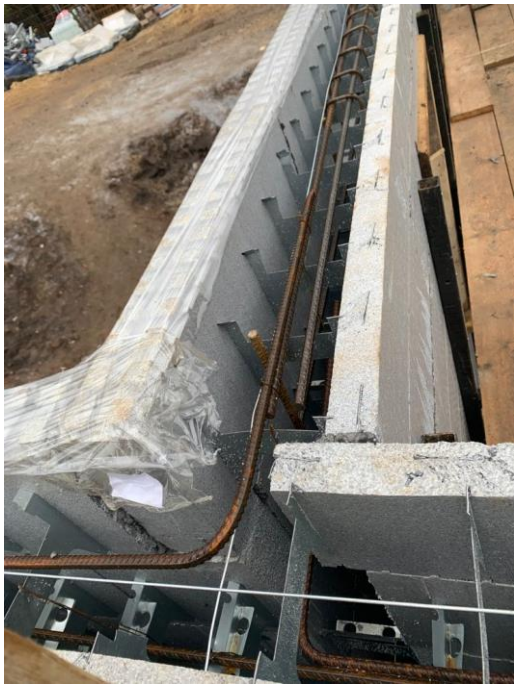

Reinforcement at "T" Junction



Reinforcement on Lintel Section

Windows & Doors

Step 1: Outline and Placement of Doors/Windows

1. Initiate the process by delineating the building's structural outline and marking the precise locations of door and window openings. This task is to be carried out on a conventional footing or slab that is meticulously level (+/- 5mm), straight, and squared.

Step 2: Initial Positioning of Blocks – (1st. & 2nd. Courses)

1. Start by placing TH-67L corner blocks on each external (90 deg.) corner of the designated area.
2. Continue by removing 50mm from the abutment end of a TH-66 to TH-67 arranging straight blocks in such a way that they extend toward the midpoint of each wall segment or door ope. Bring the second course along with the first to lock it all together.
3. Incorporate rebate blocks to craft openings intended for doors/windows. This step applies specifically to door locations and comprises the formation of the initial courses.
4. Progress through completing the first and second courses with straight blocks. Trim these blocks as needed to ensure a precise fit, all cut pieces should be increments of 150mm.
5. At this stage, ensure uniform levelness across all the blocks. If there are disparities in the level of courses, make the necessary adjustments by using shims or trimming blocks as required.
6. Check the measures and square of the set-out as supplied by Thermohouse and lock corners in position.
7. Implement horizontal steel reinforcement in adherence to specifications. Position it atop the internal webs within the block cavity, straining wire can also be installed at this time.

Step 4: Progressing Courses and Formation of Windows

1. Continue with the installation of the third and successive courses until reaching the level of the window sill.
2. Follow a comparable procedure to the formation of door openings while crafting window openings. Use rebate blocks TH67RL/67RR.
3. Before setting the blocks in place, verify the precise locations of the windows.
4. To incorporate lintel blocks into window openings, refer to the arrangement illustrated in Figure W19.



Typical Window Opening

Step 5: Placement of TH57's or TH58's

1. TH57's or TH58's Lintel closure (dependent on cavity size) are to be positioned at the base of the window head and suitably supported prior to pouring concrete see figure W19.

Step 6: Incorporating Lintel Reinforcement

1. To bear the load over window and door openings, introduce appropriate lintel reinforcement within the window head blocks. Pay attention to ensuring adequate clearance for the bottom lintel steel. All reinforcement measures should be verified by the Structural Engineer.

A comprehensive depiction of the wall reinforcement layout is available in **W12 TH-016 Reinforcing Steel Design shown previously in this manual.**



Typical Window Opening

Window & Window Cill Installation

Properly installing the DPC (Damp-Proof Course) around the window cill is extremely important.

It is of utmost importance to guarantee that the DPC component around the edges of the window cill extends vertically, no less than 50mm above the foundational point where the window frame rests on the sill.

Equally essential is the extension of the DPC beneath the sill, ensuring it extends beyond the eventual render line. It's recommended **not** to trim the DPC until after the final rendering process is complete. This approach enables any potential moisture ingress to find an outlet and escape effectively.

Below technical diagrams, and the window cill DPC guide (page 106 & 107) will show you best practice method.

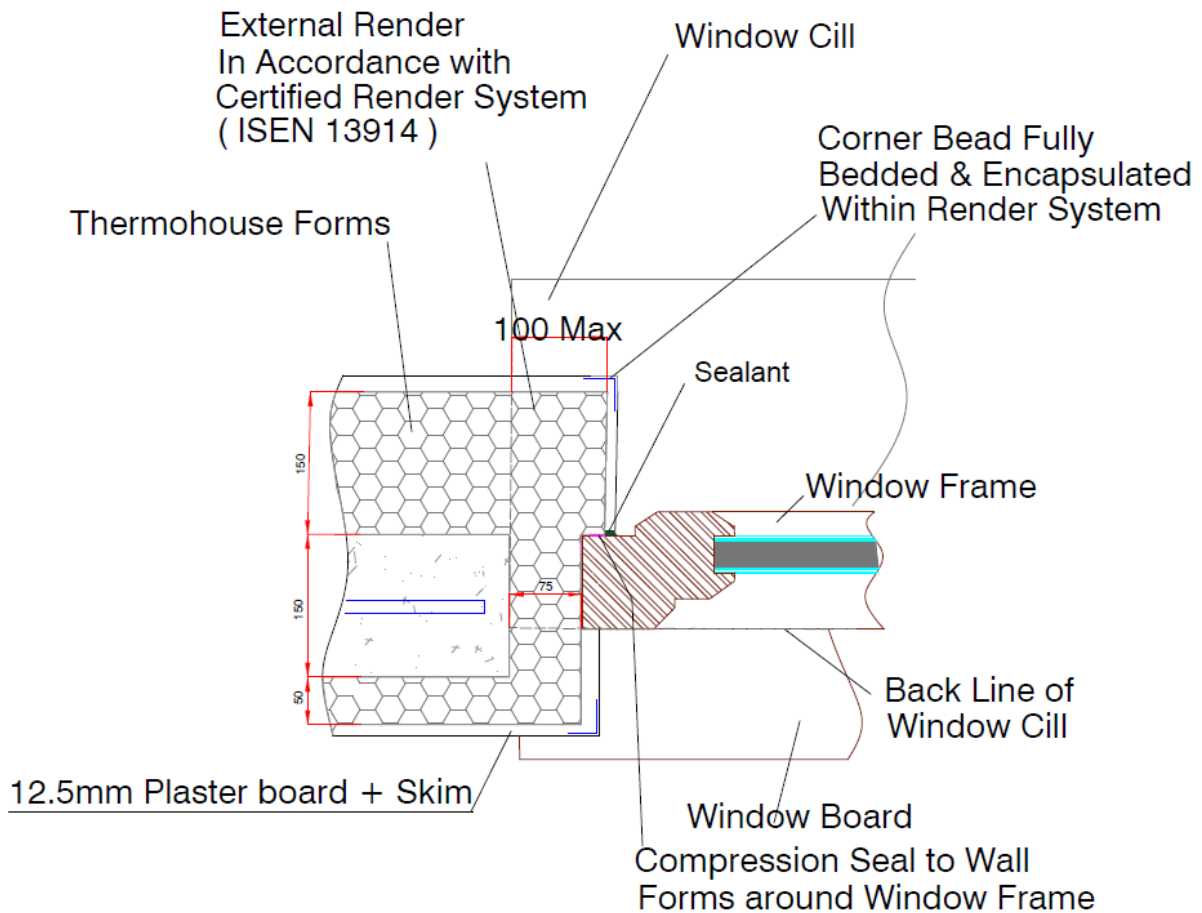

W21 – typical Window Reveal Detail

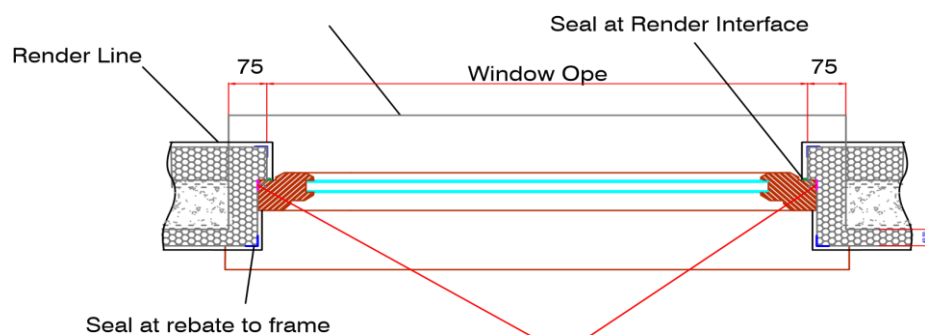
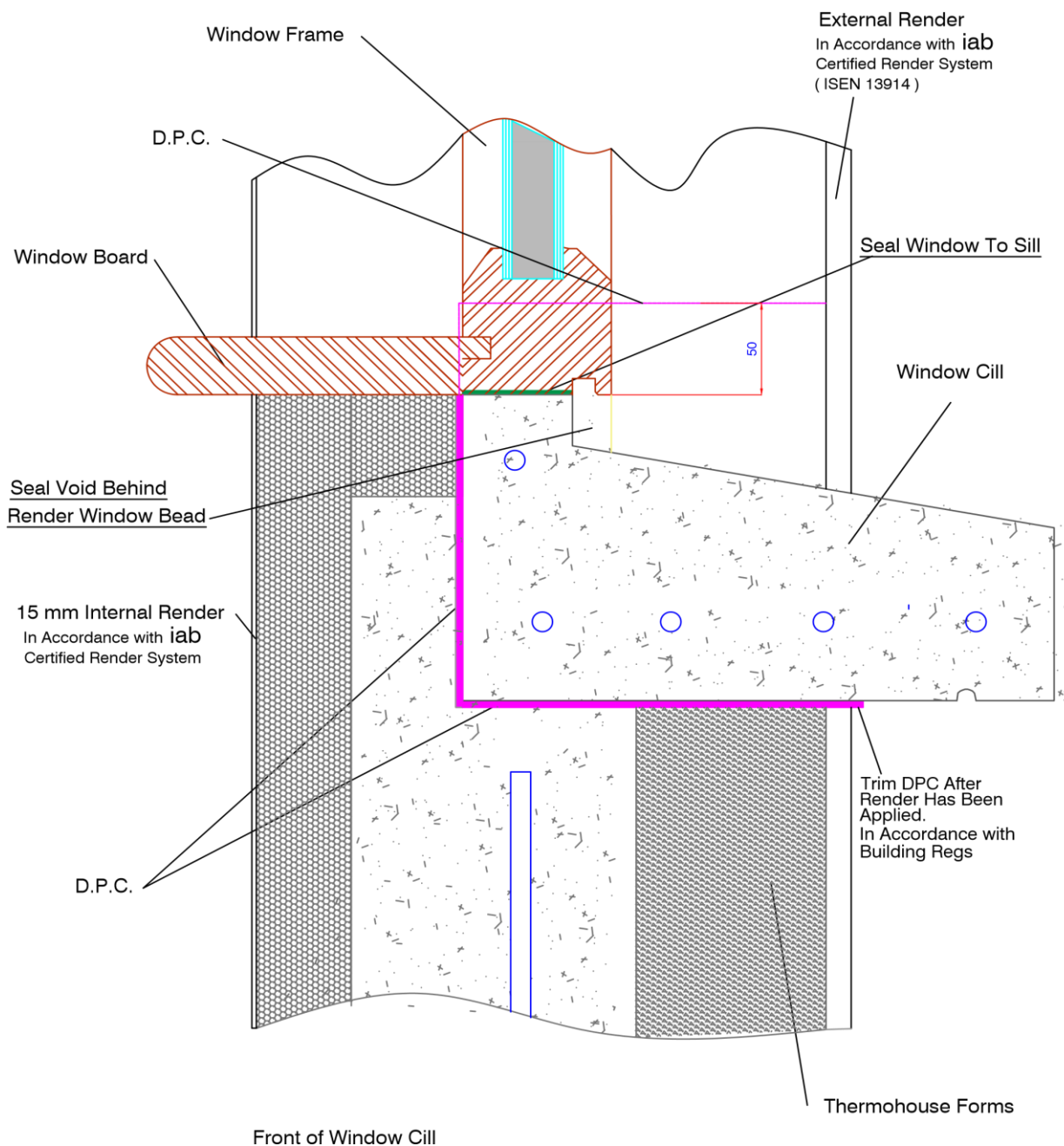

Ensure "Airtight" seal is applied in this area on each course

(Tech 7, CT1 or equivalent)

W17 – Concrete Window Cill Detail

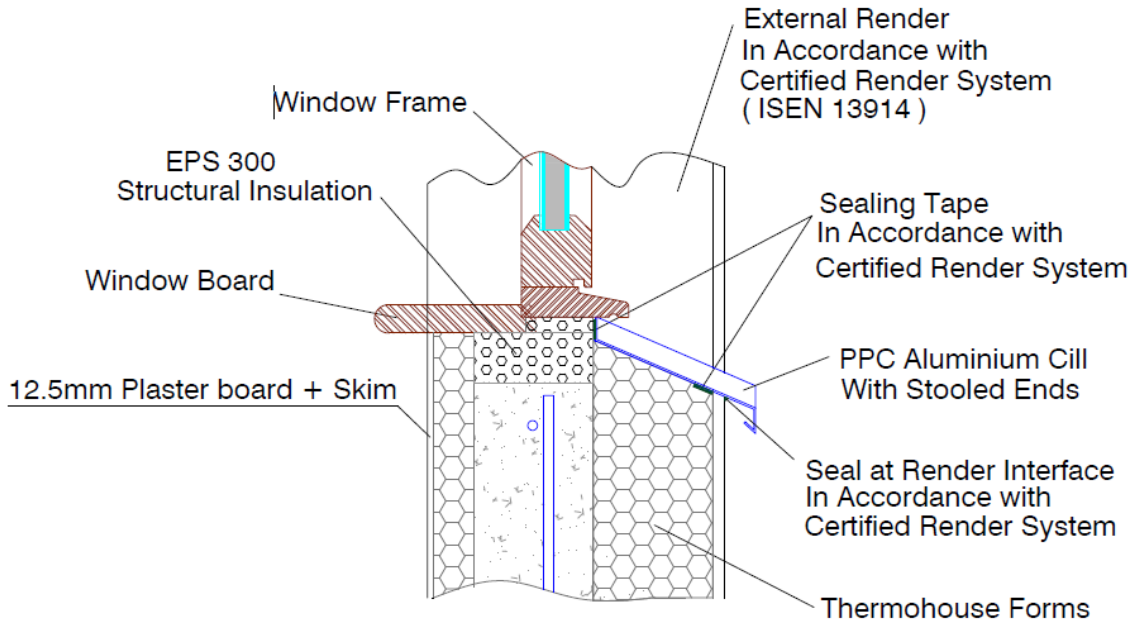

W10 – PPC Aluminium Window Cill Detail

Flush Mounted Windows

This will comprise of a rebated hardwood frame fixed externally with the window frame sealed into the rebate as shown below.

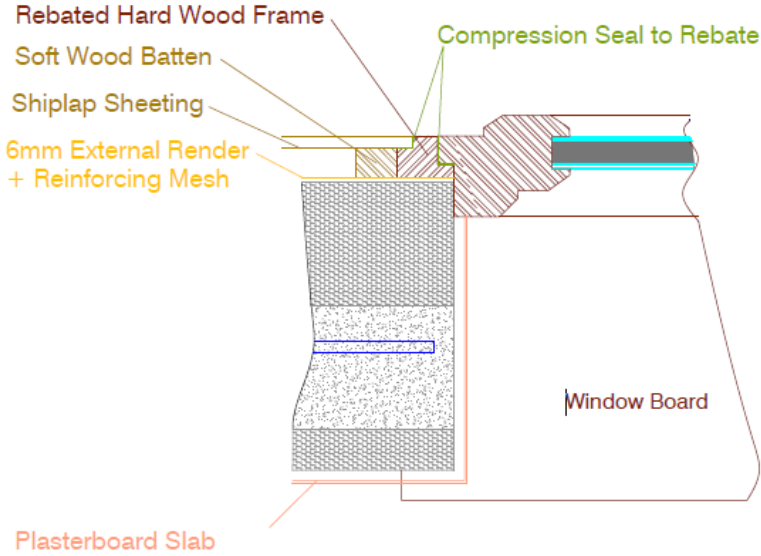

W22 - Reveal section – Flush Mounted Window

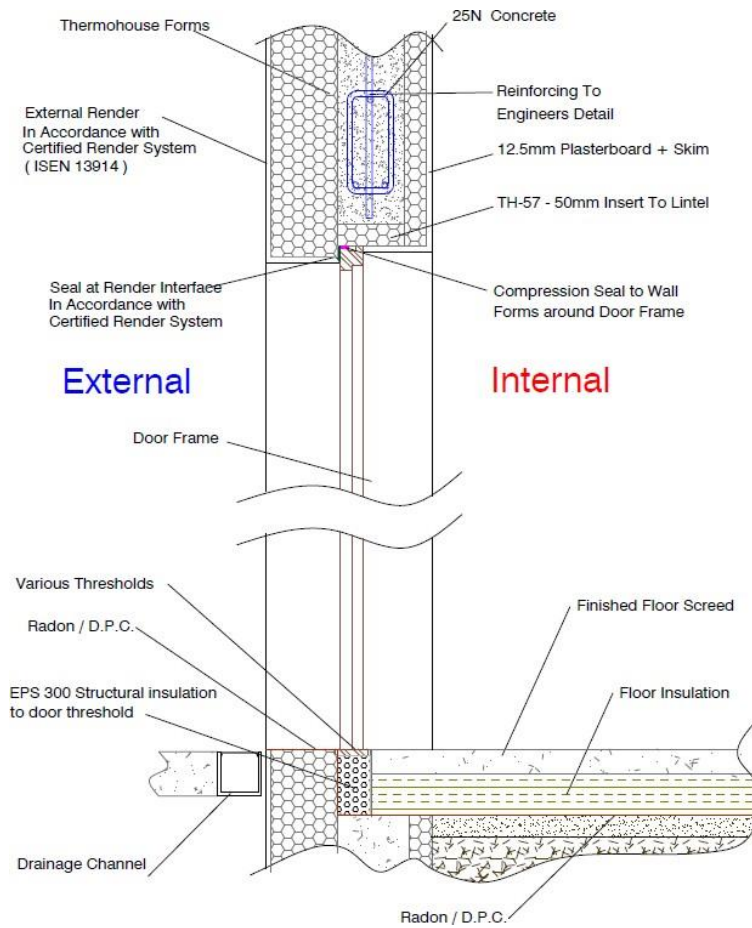

W18 – Typical Section Through Door Opening Detail

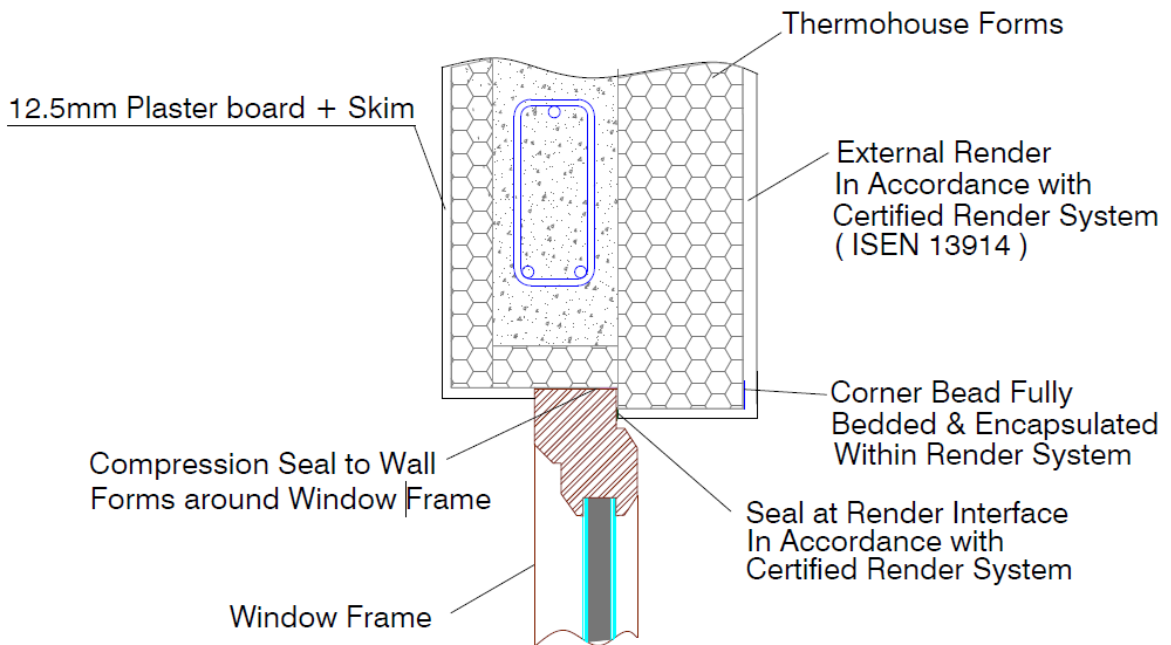

W20 – Typical Window Head Detail

Guideline and Procedure for Window Cill DPC



Window opening before preparation



Cutting & removal of plug after marking

Cut out an EPS plug 50mm higher than the window seat of the cill and flush with the back line of the cill in its seated position. This should be removed back to the line of the concrete (100mm) inside the reveal as shown.



Preparation showing plug and locking lugs on top of forms removed
Double check clearance and alignment before insertision of DPC



Insertion of DPC

Insert DPC to full height of aperture (cut out) and allow for a min. 30mm overhang of the DPC outside the wall forms.

Fold the DPC to allow it to wrap around the ends and back of the cill



Cut EPS plug to fill void on reveal above cill and insert into position.
Double check all is ok before finalising procedure.



Cut vertical line of DPC flush with forms and seal with TEC 7 or similar.
Seal EPS plug to window cill and seal top joint all around with TEC 7
Ensure DPC has a min. overhang of at least 30mm underneath the cill.
Seal the underside of the DPC to the EPS forms (**DO NOT SEAL THE DPC TO CILL**)
This DPC overhang **MUST** be maintained until after the render has been applied and finished.

Only at this stage (after render application) can the DPC be trimmed.

Extensions

The comprehensive Thermohouse complete system offers a versatile adaptability for extension projects on existing structures. When embarking on such endeavors, several crucial factors warrant careful consideration to ensure a successful integration.

Firstly, a thorough assessment of the existing structure is imperative. The input and approval of a qualified structural engineer is essential to verify the feasibility and suitability of the proposed extension. This collaborative effort ensures that the new addition aligns harmoniously with the existing framework.

Additionally, close alignment with the architectural design is pivotal. The architect's blueprint must seamlessly integrate the Thermohouse components and adhere to the prescribed sizing standards. To navigate this process effectively, the design guidelines section within this manual should serve as a valuable reference point.

When preparing for the integration of the Thermohouse system into the existing structure, it is crucial to confirm the feasibility of affixing wall starters securely. This foundational step sets the stage for a robust and cohesive assembly.

Of paramount importance is the proper support and propping of external wall corners. This precautionary measure is vital to prevent any unintended outward displacement of the walls during the concrete pouring phase. Ensuring the structural integrity of these corners mitigates potential risks and safeguards the success of the entire extension project.

For your convenience, a typical detailed illustration is provided below, serving as a valuable point of reference to inform your extension project's implementation.

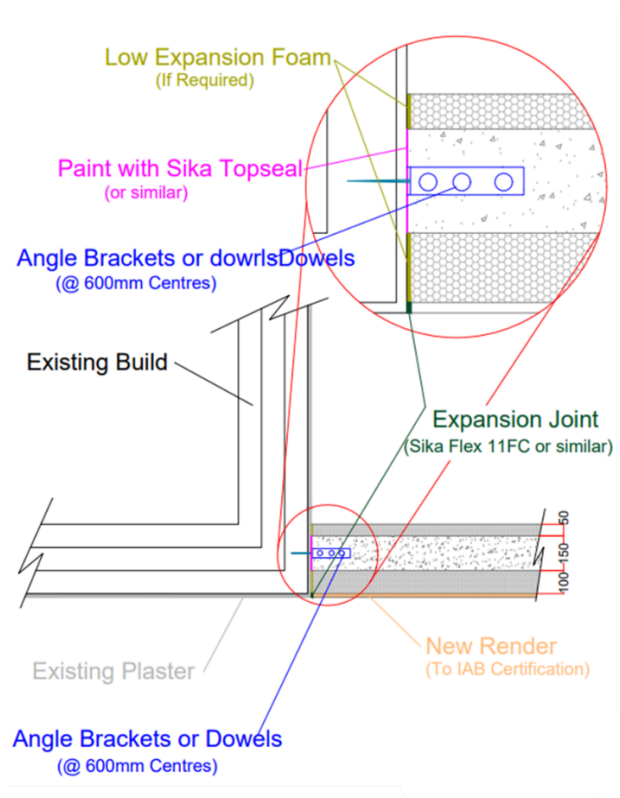

W9 Abutment to Existing Build



Services Penetrations

Examine and determine the size of all service and utility penetrations. Integrate adequately sized sleeves where necessary, being mindful of the fact that lightweight sleeves can be susceptible to damage during concrete placement. PVC sewer pipes are deemed suitable for this purpose. In instances where the penetrations are substantial, it may be prudent to seek guidance from the structural engineer, particularly considering their size and placement.

Enumerated below are potential types of penetrations:

1. Dryer Vent
2. Water Supply
3. Sewer Line
4. Electrical Main Service
5. Gas Line
6. Boiler Vent
7. Air Exchange / Heat Recovery Ventilation (HVR)
8. Bathroom Ventilation
9. Kitchen Ventilation
10. Fireplace Vent (if required)
11. Air Vents
12. Telephone Service
13. TV / Satellite Connections
14. Etc.....



Concrete Placement

When the Thermohouse system is constructed according to the stipulated guidelines in this manual, it is meticulously engineered to endure the pressure exerted by the placement and consolidation of concrete. It's important to acknowledge that each block is capable of supporting around 90 kg of wet concrete, and even the smallest concrete pump can deliver over 1 tonne of concrete per minute.

To ensure effective execution, the concrete placement and reinforcement installation must align with the standards set forth in BS8110 (pertaining to structural use of concrete) and Eurocode 2 (concerning the design of concrete structures).

Thorough compaction of the concrete is crucial, and it should be poured in a manner that guarantees complete filling of the Thermohouse system without creating voids or honeycombing. Employ a 37mm vibrating poker cautiously, avoiding direct insertion into corners and adjoining wall joints. Instead, position the poker approximately 600-1000mm away from the corner and allow the vibrations to propagate into the corner.

When commencing concrete pouring, begin by filling all walls, both internal and external, to a height of approximately 0.5 -1.0m (2 – 4 courses). Maintain this approach until the walls are uniformly filled up to the storey's height.

In instances where substantial reinforcing steel is employed in the wall forms, it may be necessary to incorporate a higher slump factor in the concrete mix. This helps prevent the occurrence of honeycombing during pouring. **Under such circumstances, exercise extra caution and diligence.**



While placing concrete, anticipate potential contingencies and diligently review the pre-pour checklist before commencing. Ensuring that the concrete used matches the specified project requirements is of utmost importance. Monitoring and recording concrete test results during placement proves more cost-effective and manageable than conducting tests at a later stage on-site.

Confirm that the concrete mix delivered aligns with the ordered specifications as indicated on the delivery ticket.

Conduct a concrete slump test for each delivery batch, recording the slump measurement before pouring.

Utilizing a pump truck with a 75mm or 100mm reducer fitted to a rubber extension is optimal for controlling the concrete pour rate. A slower flow of concrete promotes smoother placement and effective consolidation.

Proper consolidation of concrete through mechanical internal vibration is pivotal for achieving the desired wall strength. Thermohouse forms are engineered to withstand internal vibrator compaction. Choose a vibrator with a head size of 37mm.

Concrete Placement Sequence:

Step 1: Complete the pre-pour checklist.

Step 2: Initiate pouring at the centre of one wall, progressing to a height of 0.5-1m. Continue pouring in a single direction around the house, filling internal and external walls until returning to the starting point.

Step 3: Ensure continuous concrete consolidation.

Step 4: Repeat step 2, pouring the subsequent meter.

Step 5: Simultaneously fill both sides of window and door openings by moving the pump nozzle back and forth.

Step 6: Fill all lintels in one continuous pour.

Step 7: Maintain concrete placement along the full length of external walls and internal load-bearing walls. Concrete consolidation within the walls is paramount.

Step 8: While placing concrete, ensure active consolidation to eliminate air voids and ensure structural soundness.

Step 9: Continuously assess wall alignment using a string line as concrete is placed. Adjust the wall propping system as needed to maintain straightness and plumbness, utilising the adjustable turnbuckles.

Step 10: Under *NO* circumstances should the turn buckle on the prop be used to try to *PULL* the wall in, it would have to be pushed first from outside before adjusting.



Pre-pour Checklist

Date: _____ **Supervisor:** _____

Job Reference: _____

Prior to commencing concrete placement within the Thermohouse insulated forms, ensure that each item on the following checklist is checked off:

- Is the string line correctly positioned around the entire top perimeter?
- Are the walls straight and plumb, without any outward leaning?
- Have additional form supports been added to all corners?
- Have additional form supports been added to all window and door openings?
- Are all fastening screws securely fixed to the blocks?
- Is the alignment system firmly attached to the floor?
- Have all the necessary handrails and toe boards been installed in compliance with current building regulations?
- Are all lintels supporting doors and windows in place?
- Is all horizontal and vertical reinforcement correctly positioned?
- Is lintel reinforcement properly installed?
- Are all floor embedment's correctly positioned?
- Has the cavity wall been inspected and cleared of any foreign material?
- Has the appropriate concrete pump (with a maximum size of 75/100mm) been ordered?
- Have the correct concrete mix, volume, and slump classification been ordered?
- Is a concrete vibrator (with a maximum size of 37mm) available on-site and in working condition?

NOTE: If this checklist is not fully completed, DO NOT PROCEED with concrete pouring.

The pivotal stage of a successful Thermohouse project lies in concrete placement. For optimum results, it's crucial to have an adequate number of workers present. Ensure that a sufficient team is available during the pour to manage safe placement, consolidate the concrete, maintain alignment, and perform cleanup. Ideally, concrete placement should involve at least a four-person team, with one person on the nozzle, two on the poker, and another coordinating between the nozzle and pump. To ensure efficiency, consider having a crew of 5-6 members available during concrete placement.

Ensure the straightness of walls by positioning a straight line at the top course, set off 20mm from the wall, using spacers at each corner. If needed, adjust the turnbuckles to maintain wall straightness during placement.

Concrete must be supplied by an approved concrete supplier.

**The minimum compressive concrete strength for walls should be C25/30.
The concrete's workability should fall within S3 (Slump 100mm to 150mm).**

It's important to note that the specific requirements may vary from site to site and should always be confirmed by the Project Engineer. **The maximum aggregate size to be used within the Thermohouse forms is 10mm.**

Post-pour Checklist

Date: _____ Supervisor: _____

Job Reference: _____

After the concrete has been placed within the Thermohouse forms, ensure that each item on the following checklist is checked off:

- Is Concrete Consolidation Completed?
- Are Walls Aligned with String Line?
- Have All Anchors and Embedment's Been Installed?
- Has Spilled Concrete Been Properly Removed?
- Have Final Checks for Straightness and Plumbness Been Performed?
- Are Window Sill and Wall Plate Seats Levelled and Finished?
- Are ICF Locking Lugs Cleaned from Concrete Spills to Facilitate Proper Installation of the Next Course?

Wall Plate Connections

Wall Plate Preparation – ThermoRoof System

This approach to attaching the wall plate is highly energy-efficient, benefiting from the superior thermal barrier offered by the Thermohouse insulation on both sides.

Here's how to proceed:

1. Trowel the concrete surface to create a level foundation for accommodating the wall plate.
2. If necessary, insert anchor bolts into the concrete (or consider using expansion bolts or speed nails at a later stage).
3. Once the concrete has attained sufficient strength, proceed to drill the wall plate and securely fasten it to the anchor bolts.
4. Trim the external insulation to match the angle cut on the wall plate. (Refer to Figure W31 for visual guidance.)
5. Construct the wall plate using timber measuring 150mm x 75mm. On one edge of the wall plate, create a chamfered edge. This chamfer should be cut at the angle necessary to accommodate the roof's pitch, while ensuring that the chamfered face remains at a **minimum of 75mm width**. The 75mm chamfered face plays a critical role in confining compressive forces on the EPS (expanded polystyrene) material within acceptable limits.

This specific wall plate configuration is applicable in regions where the roof panel necessitates a point of attachment. This applies not only to areas like ridge and purlin supports but also to various other fixing points across the roof structure.



**EPS Chamfer for Seal
To ThermoRoof Panel**



**Installation/Fixing
Chamfered Wall Plate**

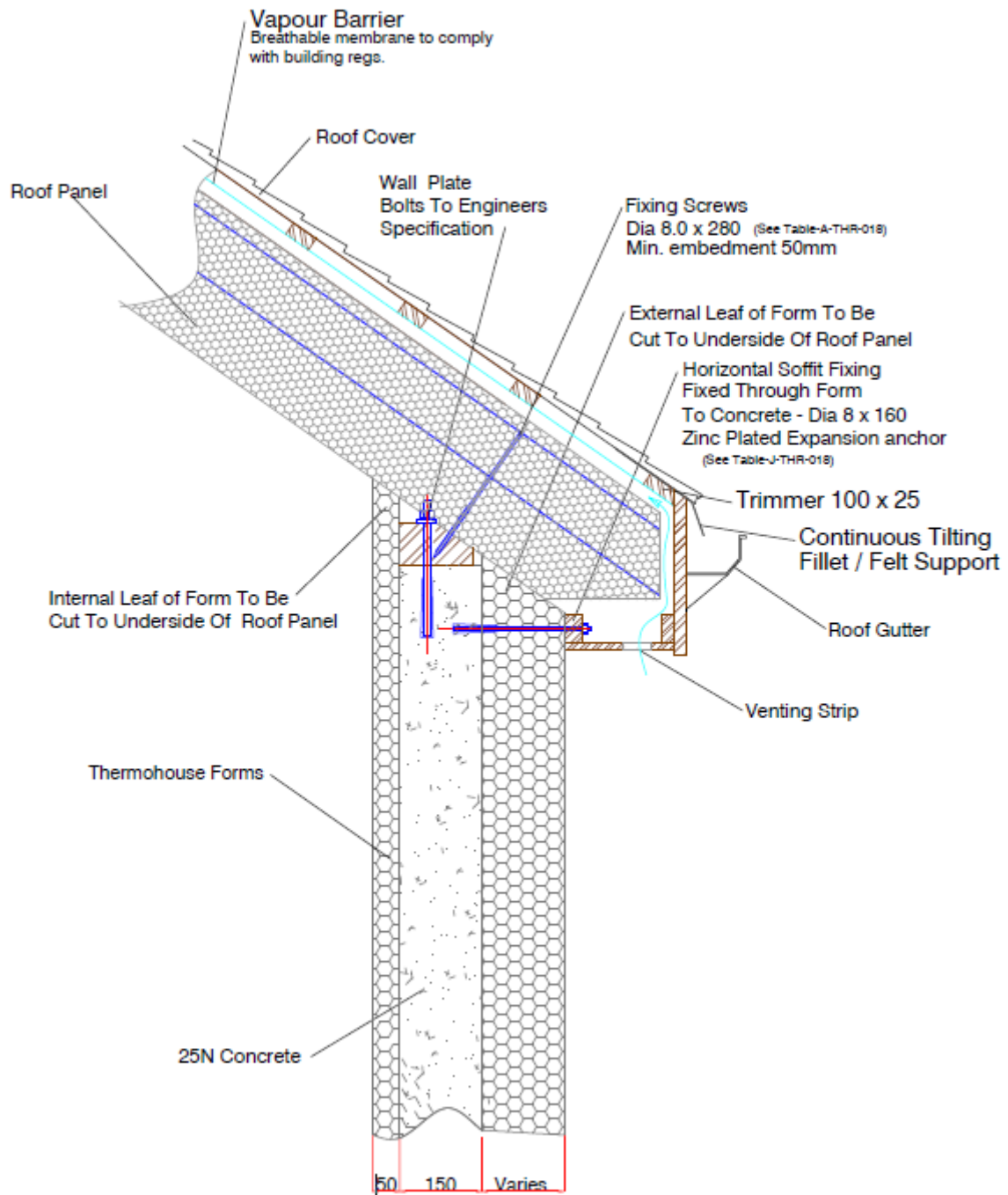

W31 – Typical Wall Plate for Thermorooftop Detail

Electrical Installation

After the concrete is in place, electrical and plumbing systems are typically installed. However

For electrical wiring and boxes, you can either attach them to the surface or cut channels into the EPS foam with a hot knife or router. Surface attachment in a service void requires fixing plasterboard to battens, which are pre-fixed to the wall. When placed directly on Thermohouse walls against the concrete, electrical boxes will protrude 13mm beyond the EPS foam to match the plasterboard thickness.

Remember that PVC cables should not touch the EPS as they can react with it. PVC cables should be placed inside conduit to prevent this reaction.

You can use tools like a hot knife, various hand saws, or a router to create spaces for wiring and boxes. A router is the most common and convenient tool for this purpose.

When PVC cables come in contact with polystyrene or polyurethane insulation, there's a risk of plasticizer migration. This happens when plasticizers, which are present in PVC cables to make them flexible, interact with the insulation materials. This can make the PVC on the cables harder and more brittle. Some cables have a non-migratory plasticizer that prevents this issue. **When using cables without this feature, it's recommended to avoid direct contact between the cables and the insulation by placing them in suitable conduits.**

Remember that all electrical wiring must follow relevant electrical regulations and standards.



Hot Knife Conduit Chasing



Installation of Large Conduit

Plumbing Installations

In most cases, buildings are designed so that plumbing pipes are not routed through Thermohouse walls, except for points of utility entry and exit.

However, there are instances where it might be necessary to embed pipes within the EPS. For instance, a vertical kitchen vent tube might need to be installed within the EPS foam. Pipes embedded in the foam should not exceed a diameter of 40mm.

For an outdoor tap, it's essential to install a hose sleeve through the wall before pouring concrete. This will enable the tap or pipe to be replaced if needed.

When connecting to an existing sewer line, determine the necessary opening's location and ensure appropriate clearances. Altering this later can be challenging.

It's advisable to consider all pipe penetrations, whether through Thermowall or Thermofloor, during the design stage or as early as possible in the construction process. This ensures that provisions are made in advance by creating voids or sleeves, allowing for the passage of services after concrete has been poured. All penetrations through the wall should be inclined with an outward fall to avoid any water ingress.



Recessed Pipe or Conduit (max 40mm)

Thermowall Finishes

Thermowall Internal Finishes

The most commonly used interior finishing material that satisfies thermal barrier requirements is the 12.5mm gypsum board. Enhanced U values can be achieved by opting for an insulated plasterboard, if you require additional insulation internally ensure that the amount of additional insulation will not compromise the point of interstitial condensation

Selecting plasterboard offers two options: a comprehensive dry system where all walls can be tape & joint finished, or alternatively, you can directly apply a plaster skim onto the boards.

For installing plasterboard within a Thermohouse, the recommended approach involves employing metal or nylon plasterboard fixings, often referred to as mushroom fixings. Another suitable method is to attach the plasterboard to the metal flanges of the blocks (positioned at 150mm intervals vertically & 250 horizontally) using drywall screws. Refer to the diagram below for the spacing between each metal fixing plate on a typical Thermohouse block.

Additionally, the walls can be battened to create a service void or provide a surface for attaching plasterboard, cladding or sheeting.

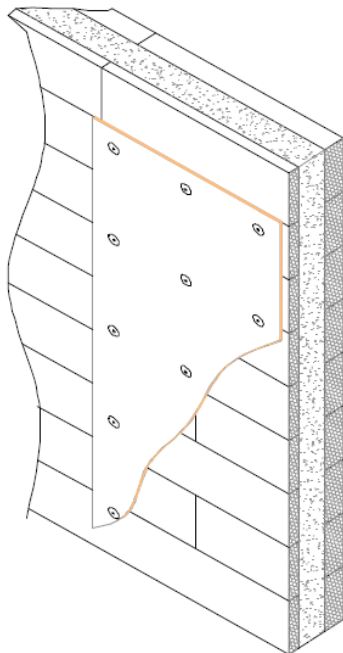

Board Fixings :-
Plastic Insulated Anchors
Installed to Manufacturers Recommendations

W28 - Wallboard directly fixed to Themowall

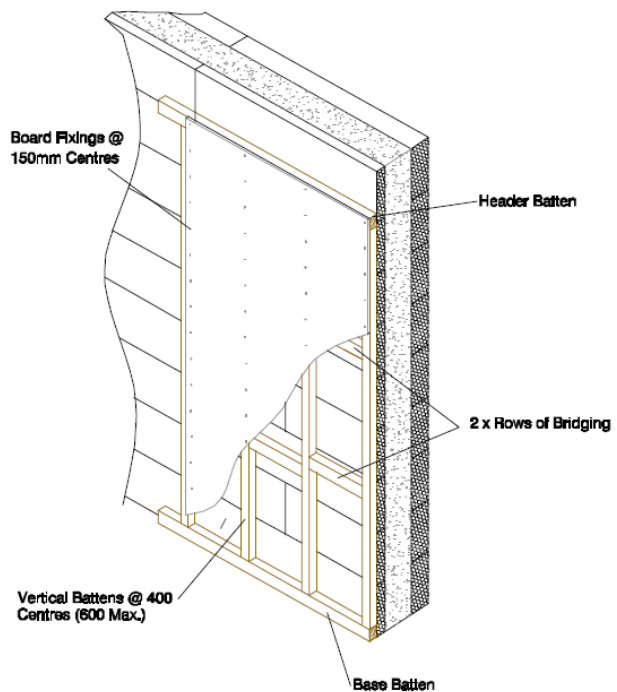

W29 - Wallboard fixed to Batten on Thermowall

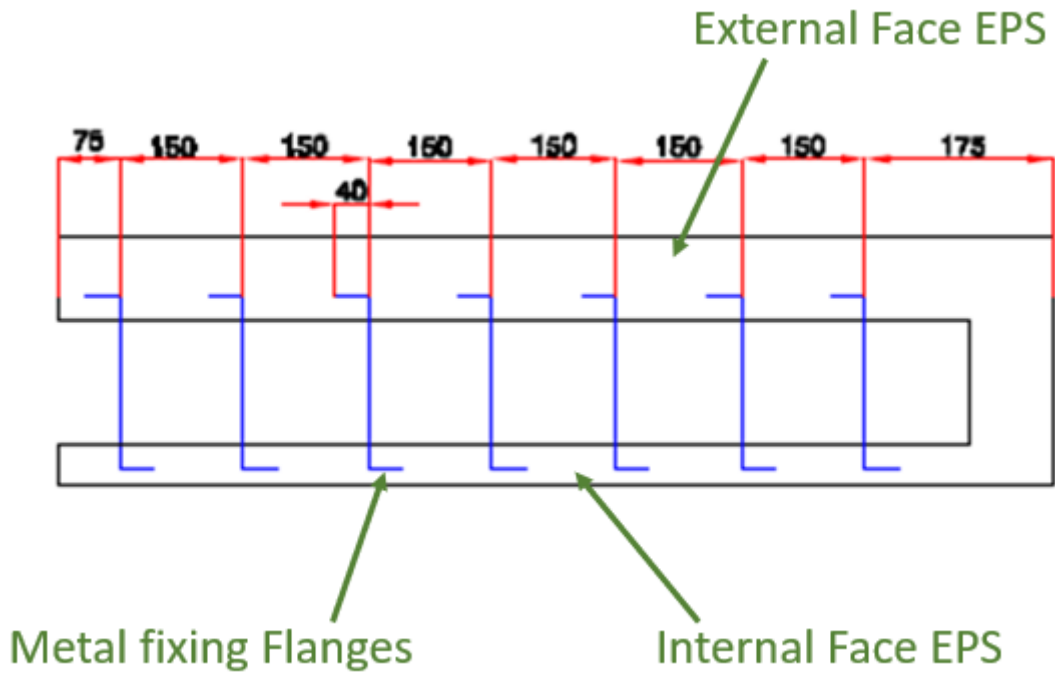

W11 - (Steel) Typical Thermowall Block Fixing Plates



**Wallboard with metal fixings
15/board**



**Fixing flange exposed
through block**







Thermowall External Finishes

Exterior finishes applied to the Thermohouse system in the Republic of Ireland must have approval or be provided by a supplier certified by the Irish Agreement Board for ICF wall use. Similar approved systems or EPS suitability should be checked for the UK market before application. Installation must adhere to manufacturer instructions and must be carried out by an approved installer selected by the manufacturer.

For external finishes like timber cladding, stone, or brick, it's recommended to incorporate a flashing/drip tray at the base and weep holes to allow any trapped moisture to escape.

When using brick or stone for the exterior, careful consideration should be given to the arrangement of external openings, wall heights, and lengths to ensure proper alignment of horizontal and vertical brick/stone coursing. Fire stops should also be planned (if required), especially when introducing a cavity outside the ICF formwork.

Insulating Concrete Formwork Render Systems have received approval from the Irish Agreement Board for use on ICF walls. There are several certified systems available in the market that are suitable.



Render Finish

The render applied to ICF blocks must be suitable for use with EPS. The render manufacturer should be able to provide guidance on its suitability. Typically, the top coat is a silicon-based or acrylic-based render commonly used on EPS.

It's crucial to follow the render application instructions provided by the manufacturer, as these can vary among different manufacturers based on their systems. Using a manufacturer-approved render installer is also recommended.

A typical approach when using render involves these steps:

- Apply a 5-7mm base coat for the first layer, incorporating a 4mm grid glass fibre reinforcing mesh.
- Apply a 5-7mm base coat for the second layer, serving as a leveling course. Ensure a minimum of 12mm for the base coat. For areas prone to high impact and for fire breaks, an additional layer of mesh can be added to the second coat.
- Apply a primer for the third coat.
- For the fourth coat, use a client-specified coloured top coat. This top coat can be acrylic or silicon-based, offering various chip sizes to achieve the desired finish (smooth or rough).

Note: Sand & Cement render is not suitable for use on EPS



The External Light weight Render is classified as a 4-coat system.

Natural Stone & Brick Finish

Natural stone and standard brick finishes can be readily achieved by integrating wavy tail brick ties or similar, which securely connect these finishes to the ICF structure. These brick ties are inserted through the EPS into the cavity of the formwork to align with the intended coursing measurements before concrete is poured.

To uphold proper spacing within the cavity, the wall ties should be appropriately sized (refer to the detail below W23).

It's important to note that these ties should be placed prior to the concrete pour; if this is not the case, they will need to be post drilled into the concrete core and positioned as required. However, having them in place before the concrete pour simplifies the process.

It's crucial to ensure that the individual conducting the installation possesses sufficient experience with brickwork techniques.



Stone & Render Finish

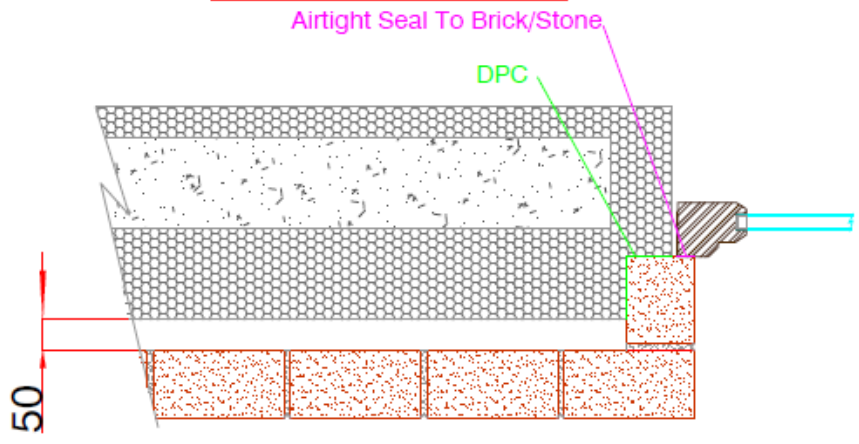
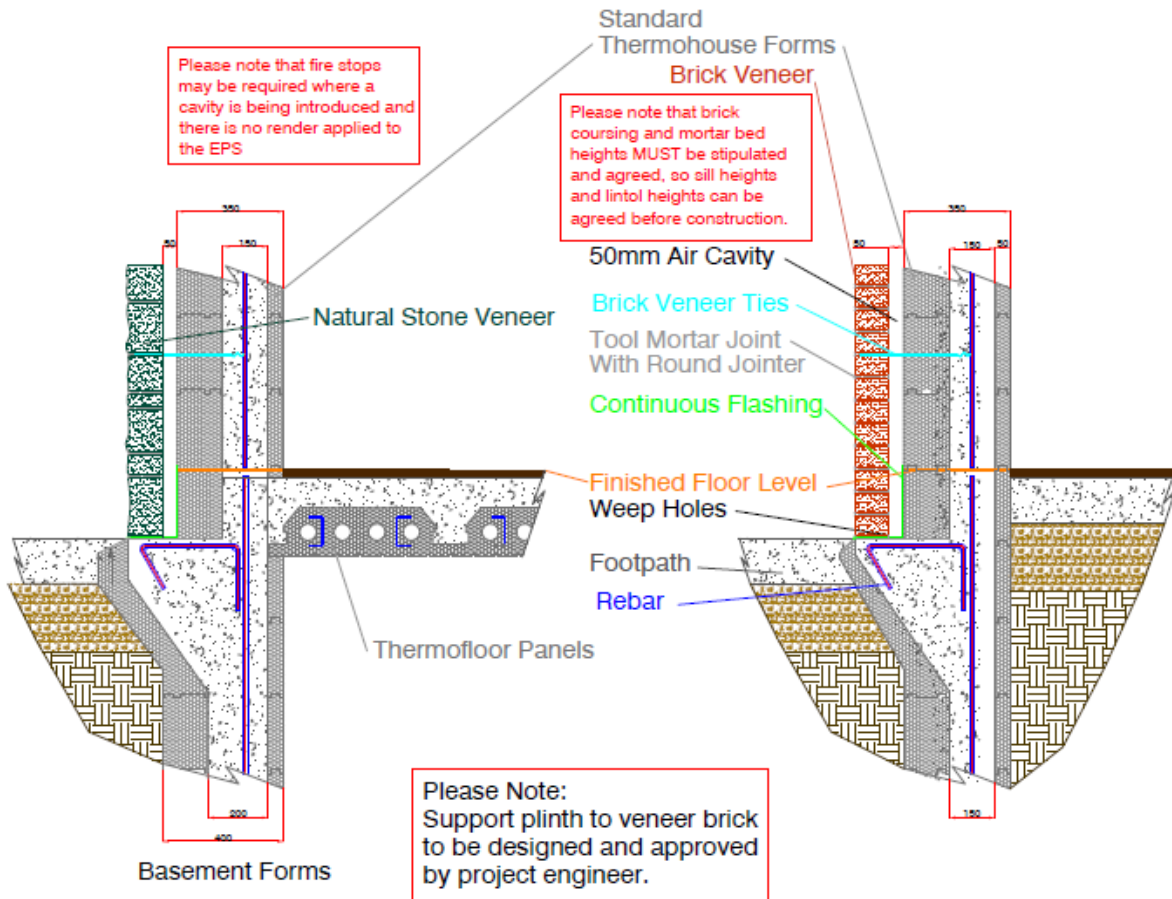

Section - Window Reveal

W23 - Typical Thermowall Finished with Stone or Brick Detail



Natural Brick Finish



Brick Slip Finish

Brick Slip / Stone Slip / Tile Finish

Attaching brick slips stone slips or tiles to the EPS is a straightforward process, and various systems are available in the market. Some systems are designed for different exposure zones, including sheltered, moderate, and severe. For severe exposure, adherence to high exposure and coastal location specifications are necessary.

Depending on the chosen system, it's recommended to have an approved installer recommended by the system's manufacturer carry out the installation according to their guidelines. **Always follow the manufacturer's installation method.**

The provided detail below is a typical example, but note that this is a non-cavity system and involves a specialised render/façade solution. It's advisable to consult specialists in this field to ensure compliance with regulations through an approved system.

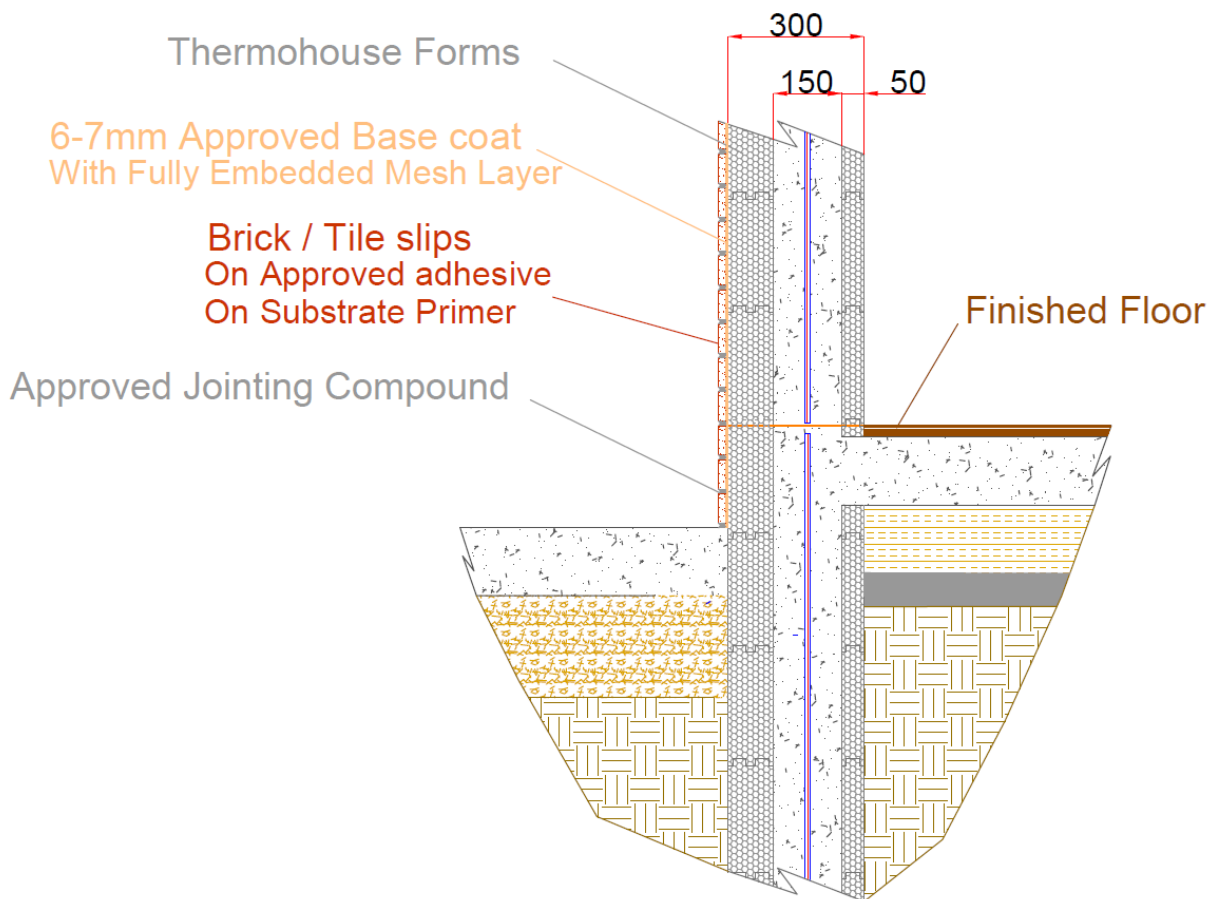

W24 - Typical Thermowall Finished with Brick Slip Detail



Brick Slip & Render Finish

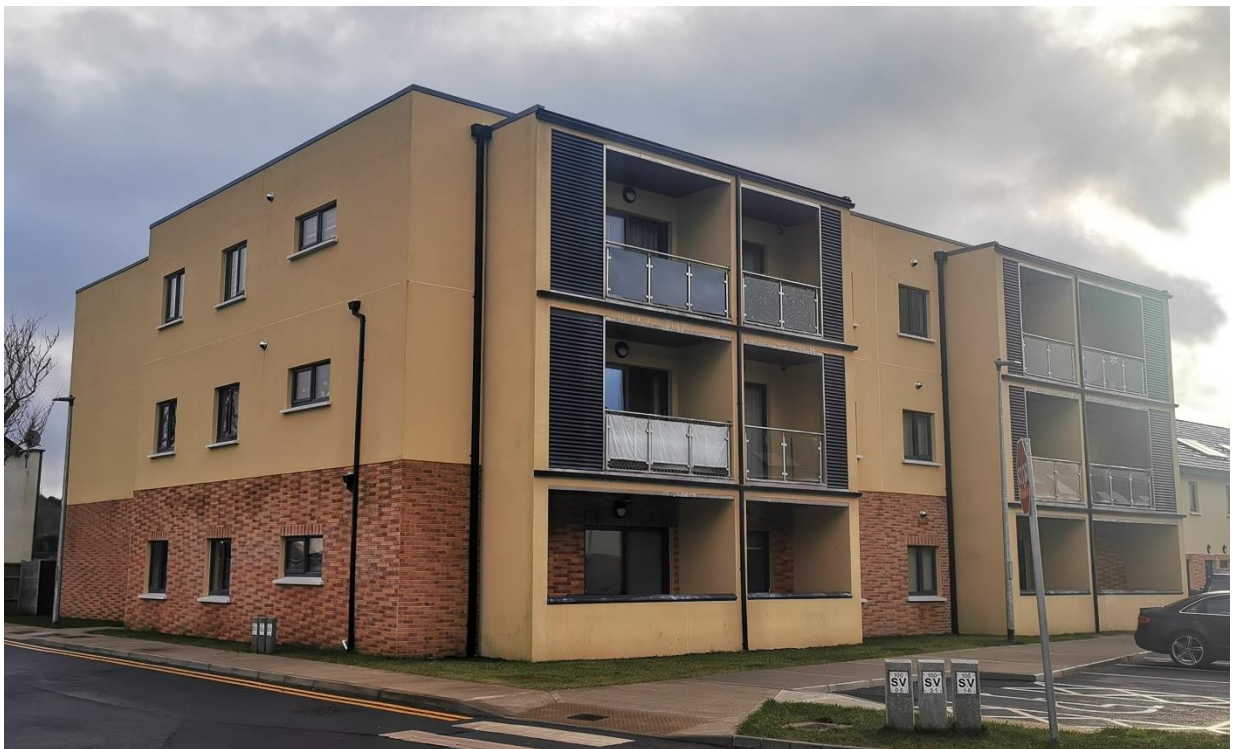

Brick Slip & Render Finish

External Baton & Cladding Finish

To secure external battens through the EPS to the concrete core, utilise concrete screws or speed nails. Ensure these fixings are appropriately sized and suitable for the task.

If a membrane is necessary behind the final cladding, an additional batten can be added. A timber cladding finish can be achieved by fixing onto batten on a breathable vapour membrane on a primary batten fixed through the EPS into the concrete core.

The orientation of the battens should match the requirements of the finished cladding.

For more details on cladding, including preparation, installation, and maintenance, refer to the handbook provided by the Timber Trade Federation:

<https://www.tdca.org.uk/publications/the-timber-cladding-handbook/>

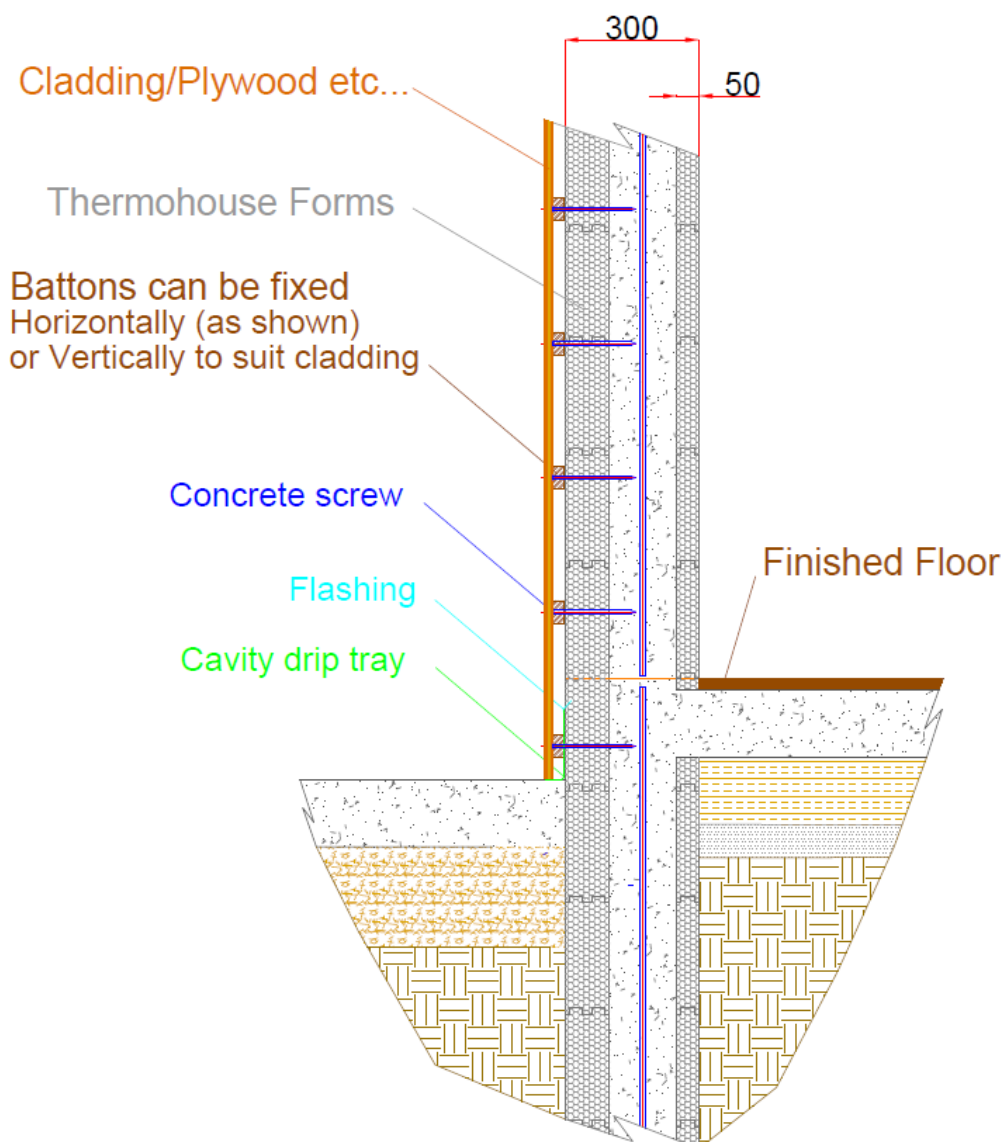

W25 - Typical Thermowall Finished with Cladding Detail



Timber Cladding



Timber Cladding with Stone Tiled walls





the complete low energy building system

Thermofloor

Flooring Systems

Concrete flooring systems

When constructing with Thermohouse blocks, you have the flexibility to consider various concrete floor system choices such as Thermofloor, pre-cast concrete, shuttered concrete, block & beam, composite metal floor decking or timber joists. Our robust walls offer superior support capacity compared to timber or steel frame structures. Concrete floor systems are typically standard in multi-residential buildings where sound and fire prevention are critical, and they are also gaining popularity in single-family residential projects.

Thermofloor

Floors designed in conjunction with the Thermohouse ICF system are capable of efficiently transmitting loads to the ground, ensuring compliance with disproportionate collapse requirements.

The Thermofloor system offers the benefits of cast concrete flooring while significantly reducing the overall construction timeline due to its quick installation (no need for cranes).

Thermofloor is a lightweight, *non-structural permanent shutter* flooring solution for ground floor (if required) but generally for intermediate floors, providing excellent thermal insulation, noise reduction, and air-tightness advantages.

Other flooring systems can be adapted to be used with the Thermowall blocks, further information on these is shown in this section.

Please refer to the delivery & Handling guide in relation to how to offload/handle and store these Thermofloor panels correctly whilst on site.

Thermofloor Elements

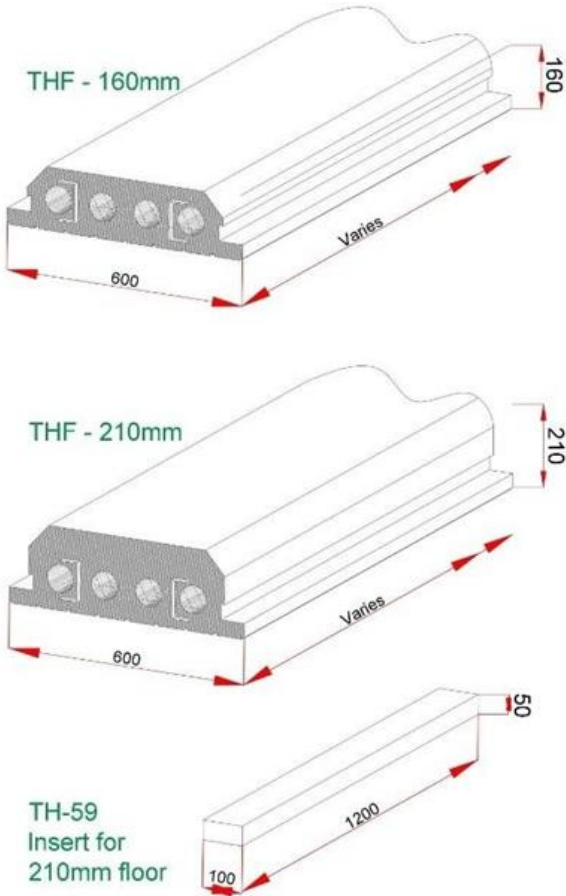

Thermofloor Components

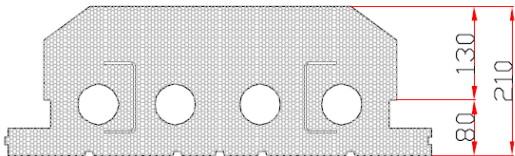

Available on request

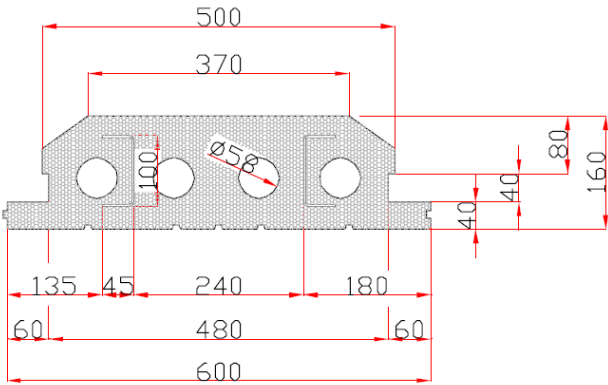

Standard Flooring Element

Thermofloor Dimensions Diagram

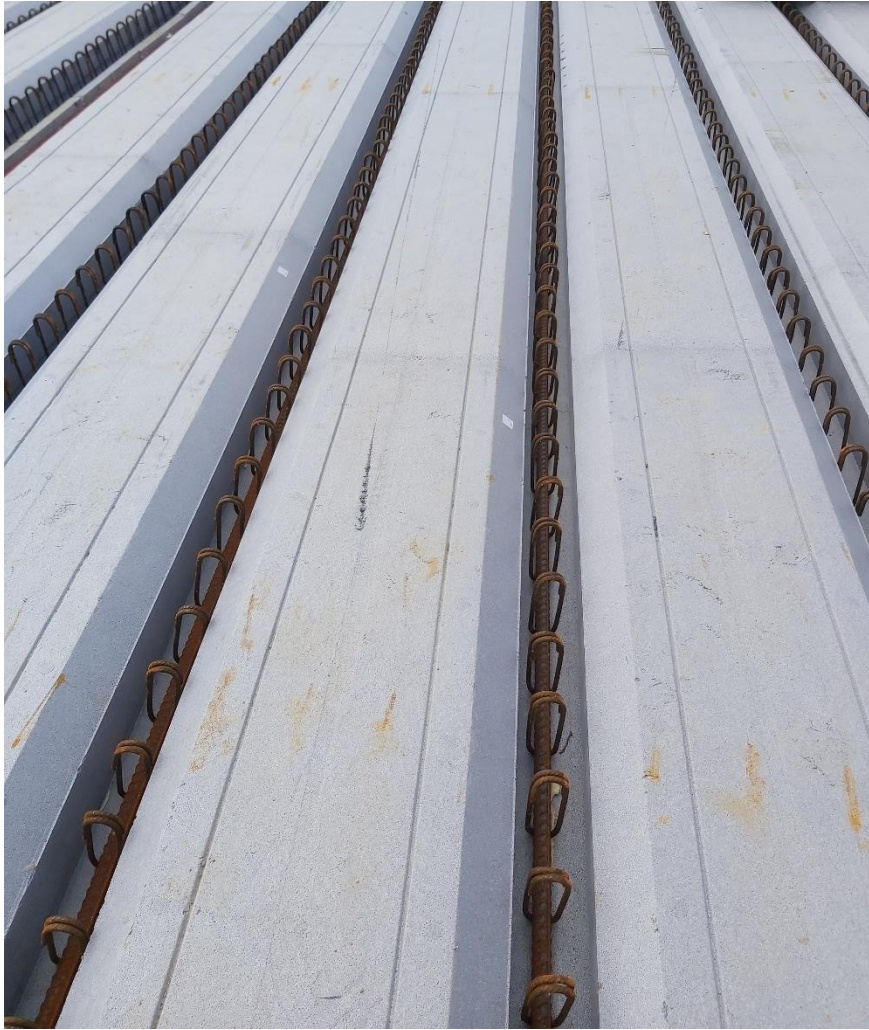

Thermofloor



The Thermowall elements, made of expanded polystyrene (EPS), are applied as the formwork for plain or reinforced concrete walls cast in-situ. The Thermowall elements comprise of two leaves of EPS, which are connected by steel inserts to resist the pressure of the concrete during filling and vibrating. The upper and lower surfaces of the shuttering leaves are tongue and groove to lock the elements together.

Size (H x W)	Max Length	Weight	U-Value Rating
160mm x 600mm	6000mm	10.0kg	-
210mm x 600mm	8000mm	10.0kg	0.160W/m ² K

Technical	
Thermal Conductivity (EPS)	0.030W/mK
Density (EPS)	24kg/m ³
Airborne Noise Tested	✓
Impact Noise Tested	✓

Fire Rating	
External Fire Spread	Class 0

Materials
EPS & Steel C-Sections

Commercial	
Typical Use	210mm Floor can be used as G/F suspended floor slab 160mm Floor can be use for all other intermediate floors



Contact Us

Phone: 0203 771 7426

Email: info@thermohouse.co.uk

Website: www.thermohouse.co.uk



Thermofloor - Ground Floor

Thermofloor can also be utilized as a ground-level suspended floor, often serving as an alternative to block and beam systems or for insulating concrete flat roofs. The achievable U-values are contingent upon the perimeter-to-area ratio, and it is advisable to have these values confirmed by the Project Engineer. Typically, minimal additional insulation is required on top of the flat roof concrete screed to prevent interstitial condensation.

When employing Thermofloor as a suspended floor at ground level, ensure that the ground conditions provide adequate support for the panel propping. At ground floor level, all the propping used will be sacrificial and will ultimately be enclosed within the void. Before proceeding with Thermofloor panels, reinforcement steel insertion, and concrete pouring, verify the suitability of all supports.

The ultimate load-bearing capacity of Thermofloor hinges on the specific reinforcement steel utilised and the thickness of the concrete screed.

You can find examples of other Floor systems in various applications within the section details provided in this section.

Following this information, you will discover a data sheet containing loading calculations for the 160mm & 210mm floor. This sheet is also available in Excel format for project engineers to employ in their specific design calculations.

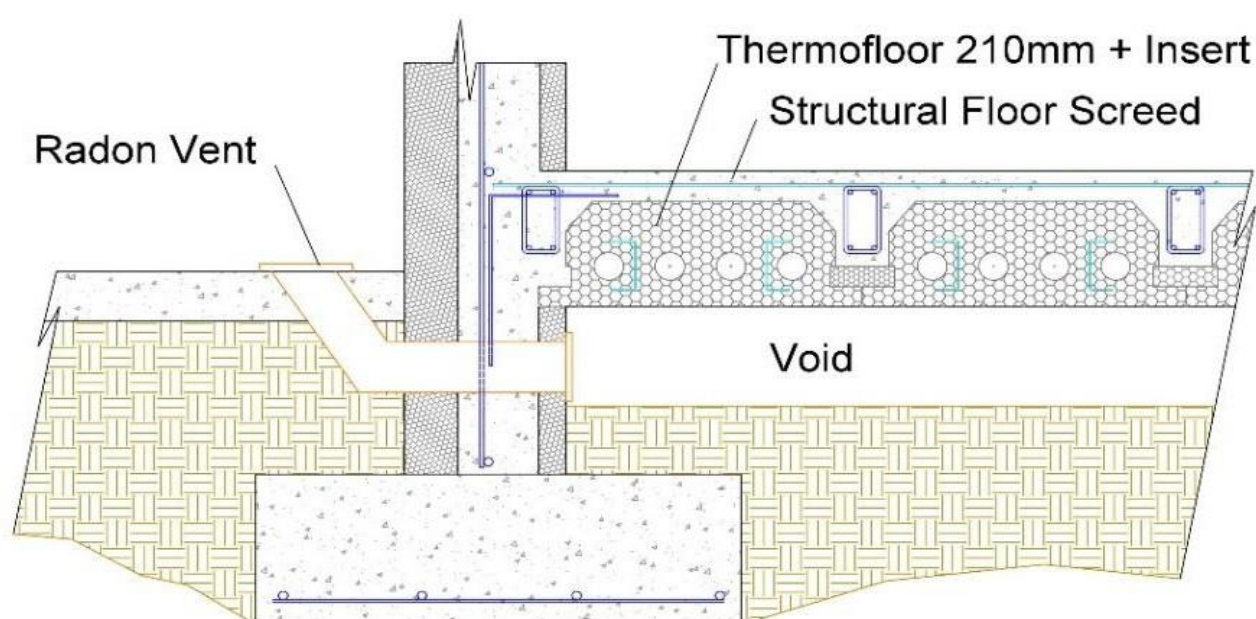

TF1 - Typical Suspended G/F Thermofloor Detail (U-Value = 0.16)

The installation procedure for Thermofloor panels closely resembles that of a hollow core slab. Thermofloor elements are positioned and supported, ensuring safety precautions are taken before steel installation. This process involves the sacrificial propping to be in place, as well as the placement of TH61 Thermowall component around the floor edge as an insulated shutter.

Once these steps are completed, the designated concrete screed is poured to finalise the structure. **Detailed reinforcement examples can be found in further sections and the Loading Calcs sheet, however it's essential for the Supervising Engineer to verify them.**

Following this information, you will discover a data sheet containing loading calculations for the 210mm floor. This sheet is also available in Excel format for project engineers to employ in their specific design calculations.

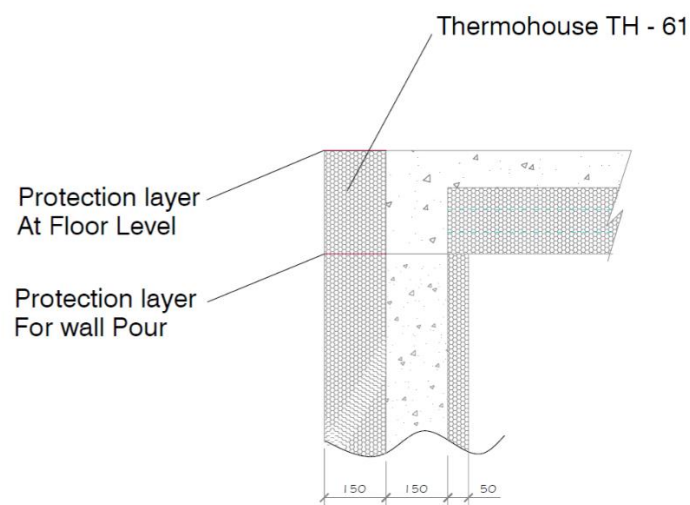

TF2 - Typical Placement of TH21 external leaf in line with Floor panel placement.



TF3 Edge Support to TH21 course at floor edge

Design according to EN1992-1-1:2004 Incorporating Corrigenda January 2008 and the Irish National Annex

NOTES:

1. Input values in blue cells
2. This spreadsheet covers simply supported beams only.
3. User to input blue cells only.
4. Maximum allowable span is 9.0m.

PROJECT #:

BEAM NAME:

CALCS BY:

CHECKED BY:

DATE:

GEOMETRIC DATA

Element Type =	H210
hf (mm) =	100
bw (mm) =	100
cp (mm) =	600
o (mm) =	25
H tot (mm) =	270
beff, 1-2 (mm) =	250
bf (mm) =	600
Bar DIA (mm) =	20
Link DIA (mm) =	8
d (mm) =	228

SECTION ANALYSIS: BENDING

K =	0.0188	
z (mm) =	218	
x (mm) =	28.8	OKAY
As,req'd (mm ²) =	168	
As,min (mm ²) =	32.9	
As,max (mm ²) =	1080.0	
Select reinforcing =	1-20Φ	
As,prov'd (mm ²) =	314	OKAY
Clear bar spao., if applloable (mm) =	N/A	
Minimum bar spao. (mm) =	25	OKAY

SECTION ANALYSIS: SHEAR

Ved (kN) =	12.44	
ved (Mpa) =	0.64	
Angle of Strut (°) =	21.80	
Asv,req'd (mm ² /m) =	60.0	
Asv,min (mm ² /m) =	84.7	
Select reinforcing =	2-8Φ	
Select spacing =	125	
Asv, prov'd (mm ² /m) =	804	OKAY
Max. long. spacing (mm) =	171.8	OKAY
Vrd,o (kN) =	17.9	
Vrd,s (kN) =	190.2	
Vrd,max (kN) =	74.8	

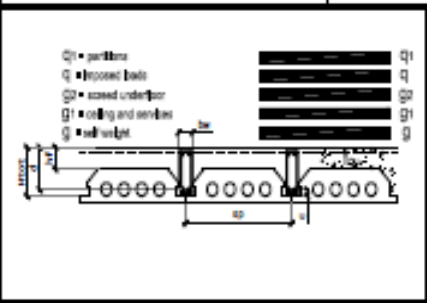

LOADING: PERMANENT

SDL (kNm ²) =	1.85
Screed w = [mm]	0
Beam SW (kNm/m) =	1.85
SDL (kNm/m) =	0.99
Screed SW (kNm/m) =	0.00
Total Permanent Load (kNm/m) =	2.84

SECTION ANALYSIS: TRANSVERSE SHEAR

Theta	28.5	
Max. Strut Comp. Stress (Mpa) =	3.38	
k*fold (MPa) =	0.62	
v,ed (MPa) =	0.22	NO TRANSVERSE REINF. REQ'D
Acfc (mm ² /m) =	24.88	

LOADING: IMPOSED

Imposed (kNm ²) =	1.50
Partitions (kNm ²) =	0.00
Imposed (kNm/m) =	0.90
Partitions (kNm/m) =	0.00
Total Imposed Load (kNm/m) =	0.90

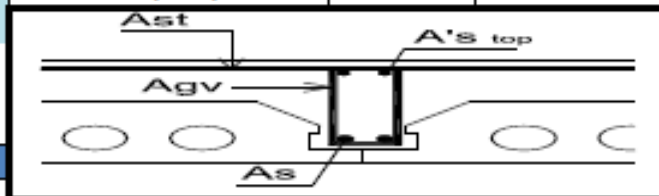

LOADING: TOTAL

Total Serviceability UDL (kNm/m) =	3.74
Total Ultimate UDL (kNm/m) =	6.18

DEFLECTION

Kb	1	**NOTE: PROPS AT 1/2 REQ'D**
L/D,allowable =	40.00	
L/D,actual =	20.96	OKAY

MATERIAL STRENGTHS

fou (MPa) =	C28/35
fyk (MPa) =	600

STRUCTURAL ANALYSIS

Span (m) =	4.80
Check at 'x' from support (m):	0.20
M@x (kNm) =	2.38
V@x (kN) =	11.40
Mmax @ midspan (kNm) =	14.92
Vmax @ support (kN) =	12.44

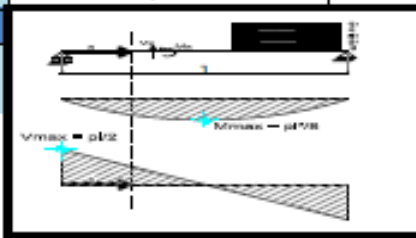

SUMMARY

Beam Size:
100wide x 270deep
Bottom Reinforcement:
1-20Φ
Links:
2-8Φ @125

Thermofloor Intermediate Floors

For intermediate floors, the 160mm Thermofloor sections (span up to 6.0m) are typically used instead of the 210mm (span up to 8.0m). This choice is mainly driven by the fact that intermediate floors don't necessitate reduced U-values. This decision helps save on floor height build-ups.

The Thermofloor 160mm is suitable for use as a party wall floor because it meets building regulations' requirements for Airborne Acoustics and Impact Acoustics (when used with an Impact Mat). It's also considered a structural floor slab once concrete has been poured.

The installation process for the intermediate Thermofloor is similar in principle to the ground floor slab. You'll still position the floor sections over the relevant structural supports or walls and prop the underside of the floor panels while preparing for the concrete pour.

ThermoFloor 160mm panels can span up to 6m (210mm 8.0m) and support various loads. The reinforcement and screed depth should be adjusted based on the engineering requirements for the specific span. **Detailed reinforcement examples can be found in further sections and the Loading Calcs sheet, however it's essential for the Supervising Engineer to verify them.**

Following this information, you will discover a data sheet containing loading calculations for the 160mm floor. This sheet is also available in Excel format for project engineers to employ in their specific design calculations.

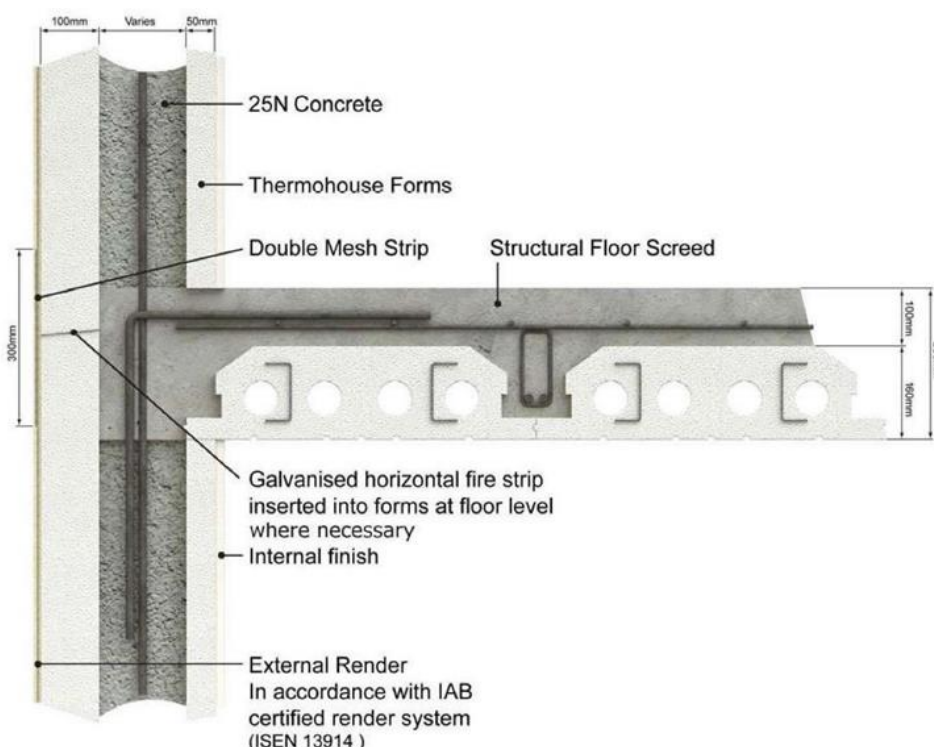

TF4 - Typical Intermediate Thermofloor Build Up.

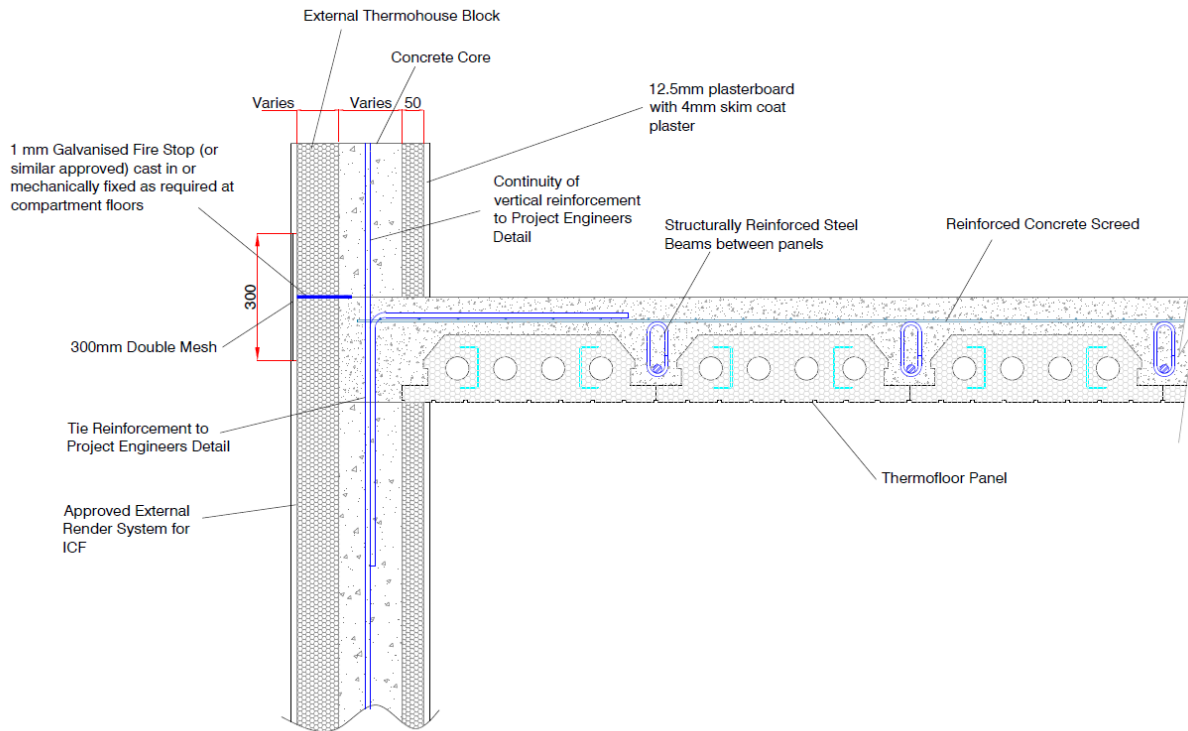

TF5 - Typical Intermediate Thermofloor Section Detail

When installing concrete flooring, you'll need to lay a course of TH-61 blocks on the top course of the blockwork on the outer insulation layer. Special attention is required for propping and casing since this TH-61 on the top course of the block is not connected to an internal face.

It's recommended to tape or cover the top of the outer insulation of the Thermohouse block at ceiling level to protect it from concrete spillage when pouring the wall structure. This will safeguard the external nipples for connecting TH21/TH-61's rising to the floor level pour. Repeat this process on the top of the TH-61 when pouring the floor to enable the connection of the first course to the next level.

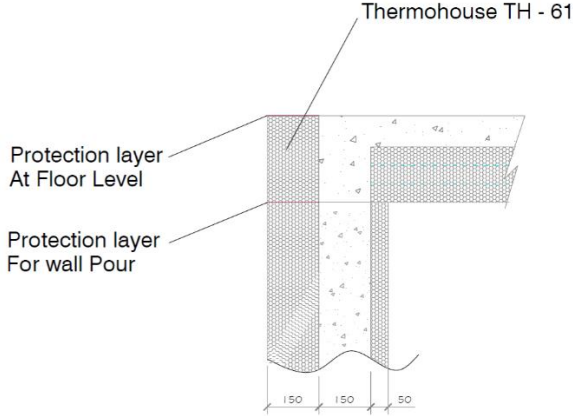

TF2 Typical Placement of TH21 external leaf in line with Floor panel placement.

If necessary, underfloor heating can be installed on the Thermofloor panels before the concrete pour. The heating pipes can be pinned to the panels or tied to the reinforcement mesh. Ensure you select a system suitable for burial into the concrete. Also consider their depth for the placement of the props for the first floor wall supports.

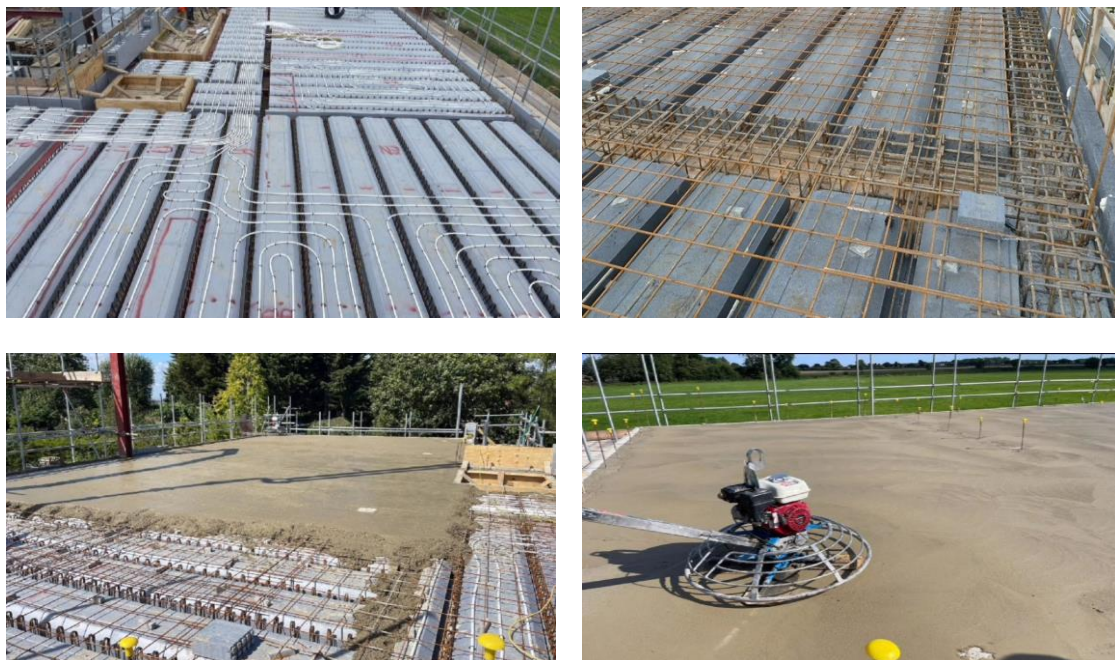

All services passing through the floor should be considered and cut before the pour, with shuttering in place to contain the concrete. This proactive planning will save time and costs.

If required, and once the concrete has cured, it's possible to remove some of the EPS from the underside of the Thermofloor panel to create a service void if necessary.

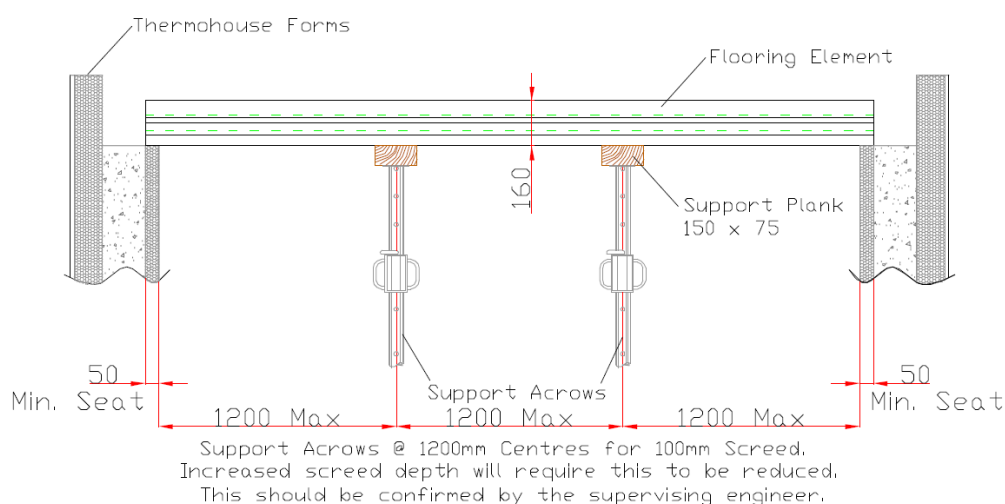

It is recommended that the support planks are a minimum of 150mm x 75mm and the

TF6 Typical Thermofloor Propping Support

support acro's are placed at a maximum of 1.5m Centre's. It is necessary to have the support system verified by the Supervising Engineer before placement of reinforcing steel and concrete.



TF7 - Typical Thermofloor Propping Support prepared to take floor above

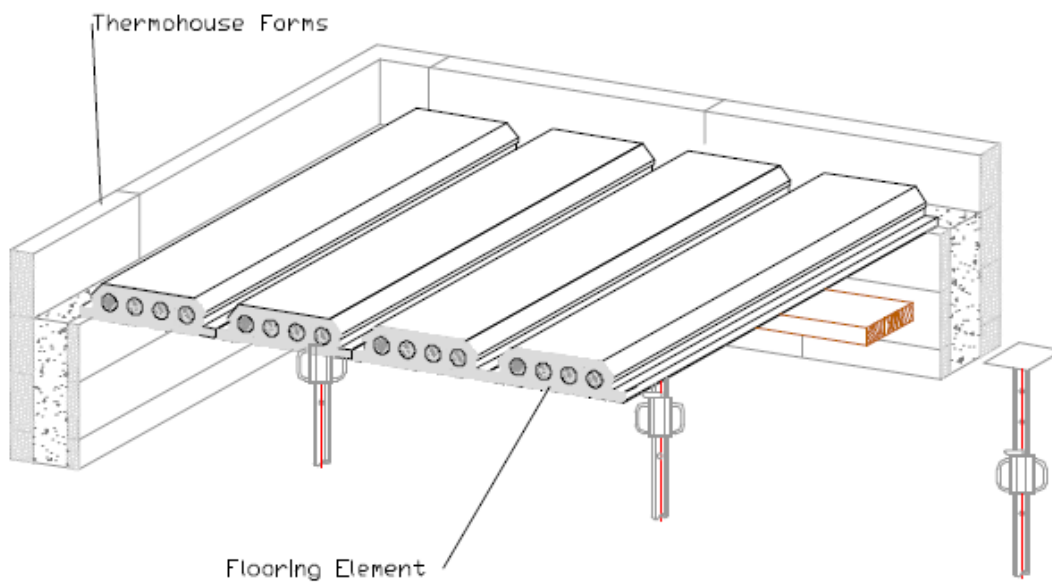

TF8 Step 1 – Place acrows and supports in place to place thermofloor over

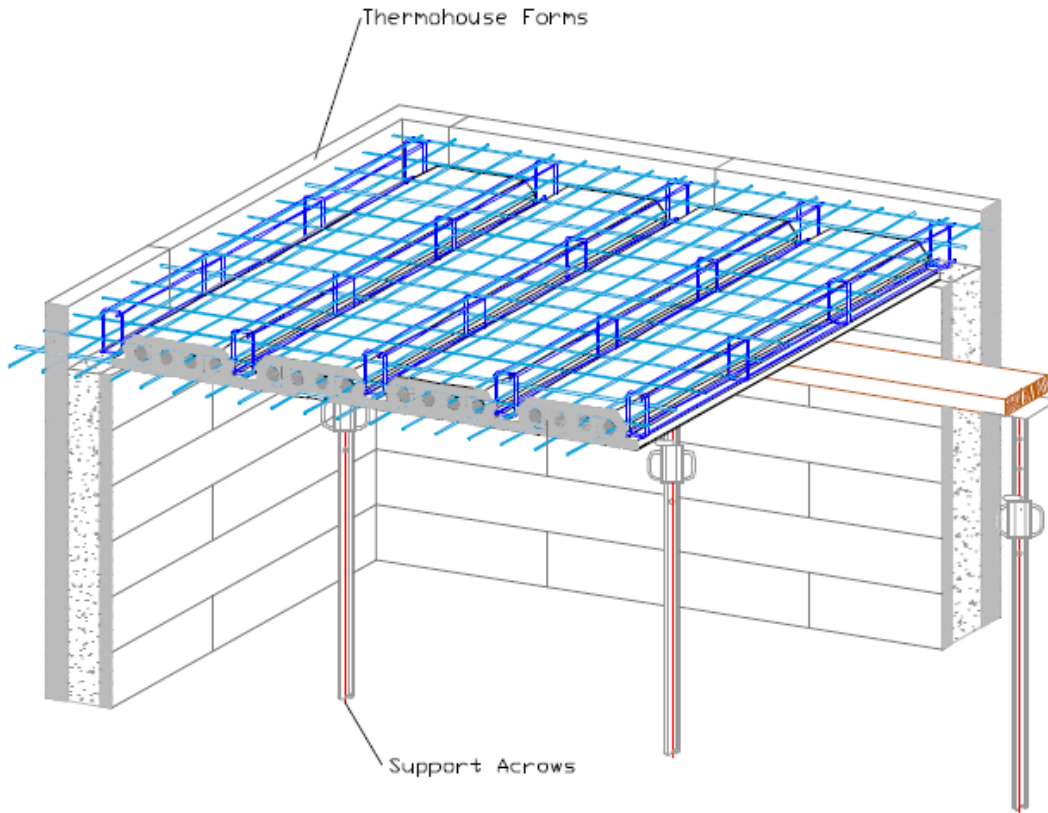

TF9 Step 2 – Place “T” beams and steel mesh into position over top of floor, Also connect Rebar from wall onto floor rebar.

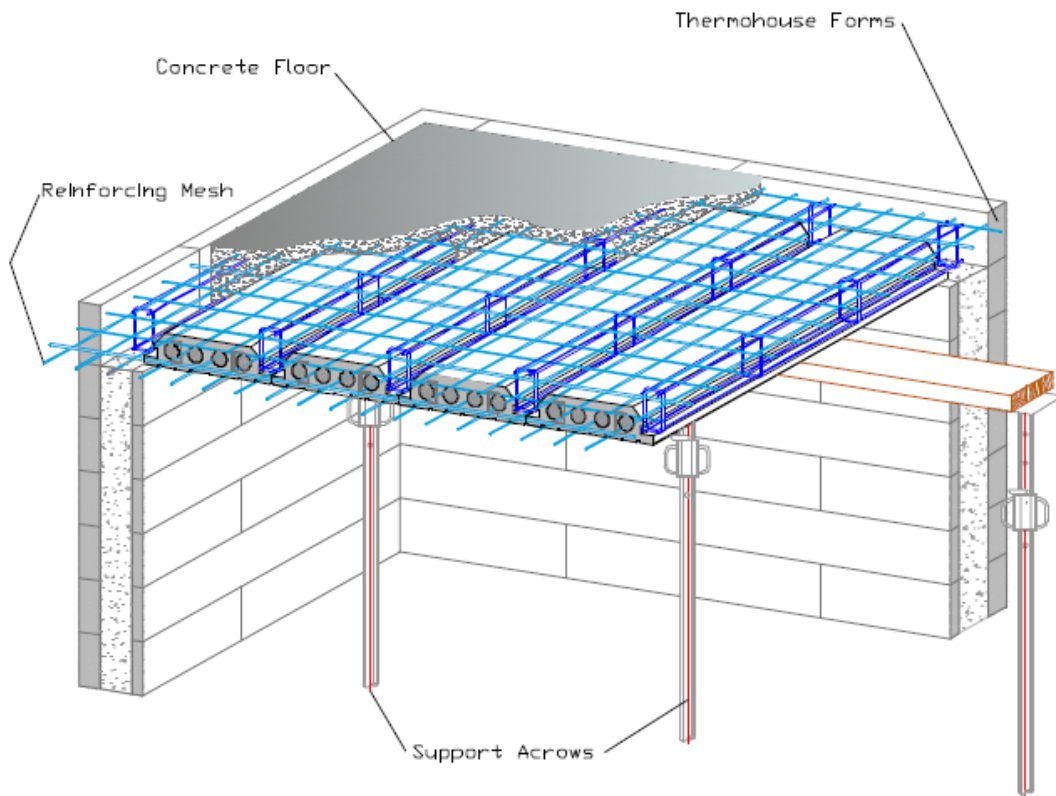

TF10 Step 3 – Place concrete to the required thickness over floor covering all the steel Reinforcements

Once the concrete has fully cured (28 days) and the floor is safe for walking on, you can proceed to remove the support propping below. Once dry, the floor will serve as a secure working platform, enabling the construction work to progress on the higher levels. This also allows for second fix works to be carried out on the lower levels.

The diagram below illustrates the extent of concrete coverage area.

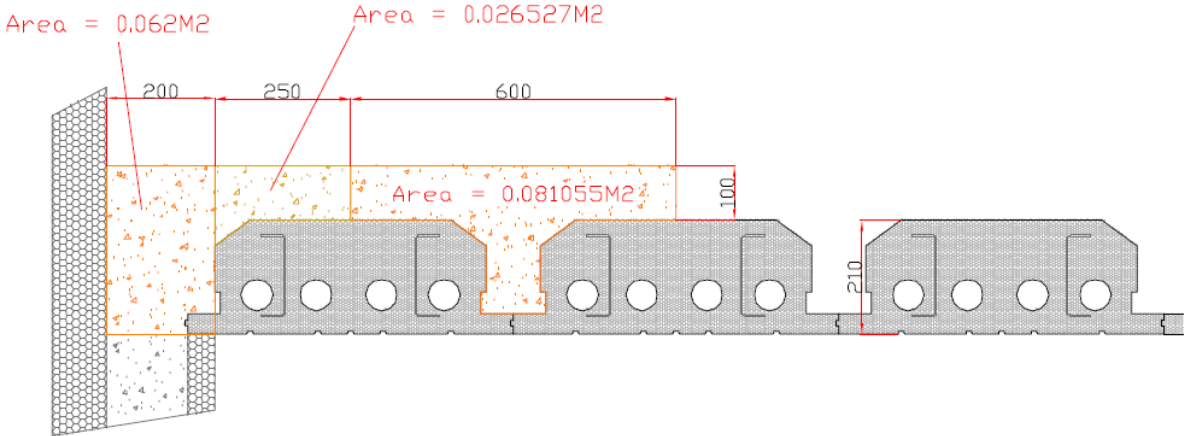
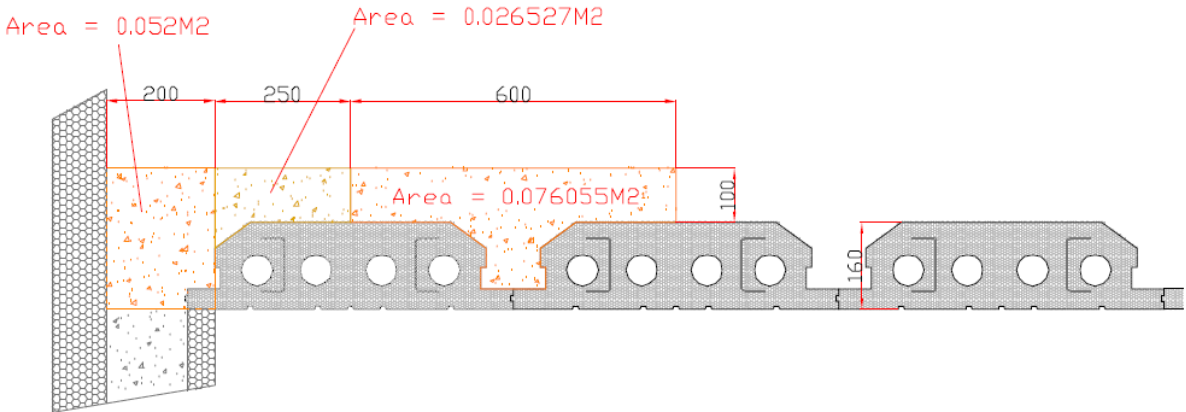

TF11 Typical concrete area coverage

Thermofloor – Build Ups

Exemplary Floor Constructions using Thermofloor are depicted below. It's crucial to address this aspect during the initial design phase, as it could influence the vertical space available from underside of floor panel to ceiling level for a service void.

When integrated into the early design and planning application stages, this can be seamlessly incorporated. It's essential to meticulously assess the service void's dimensions, taking into account the size and nature of the services that will have to be accommodated.

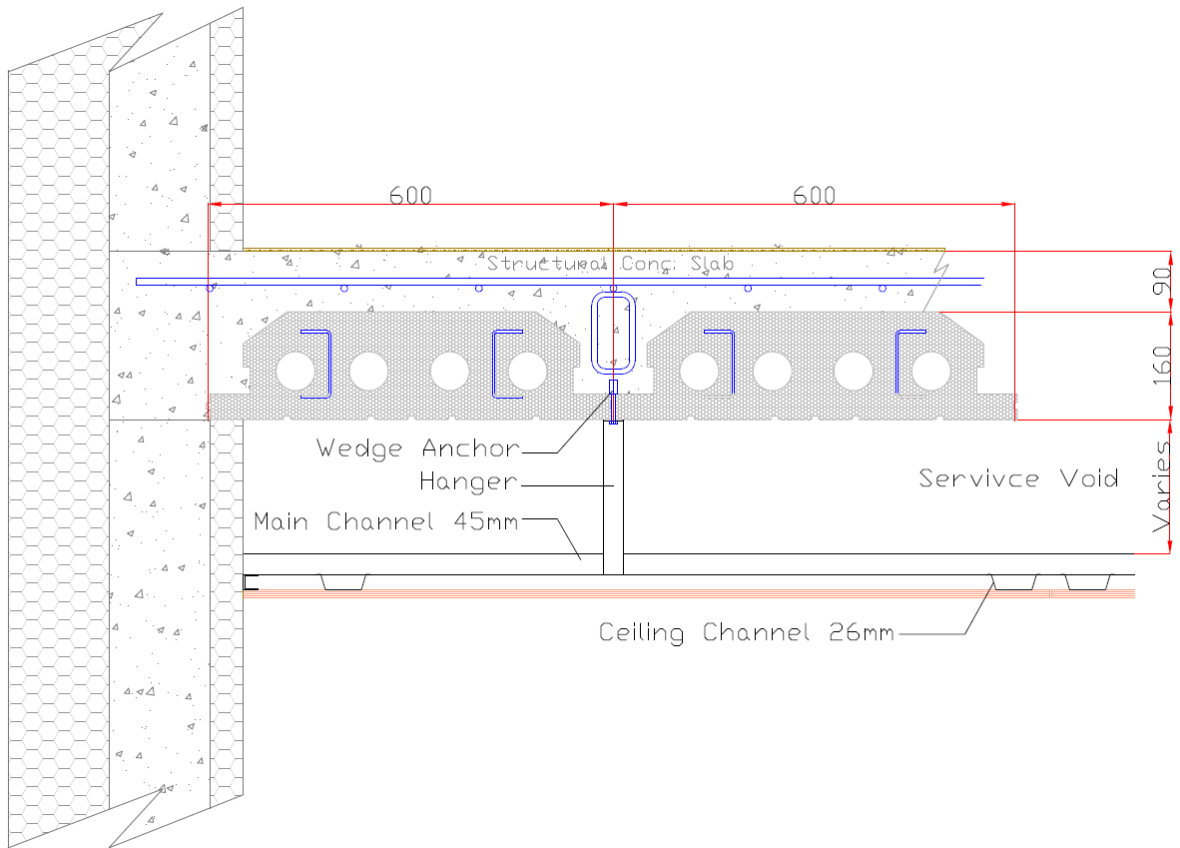

TF21 - Typical 160mm Thermofloor suspended floor build up

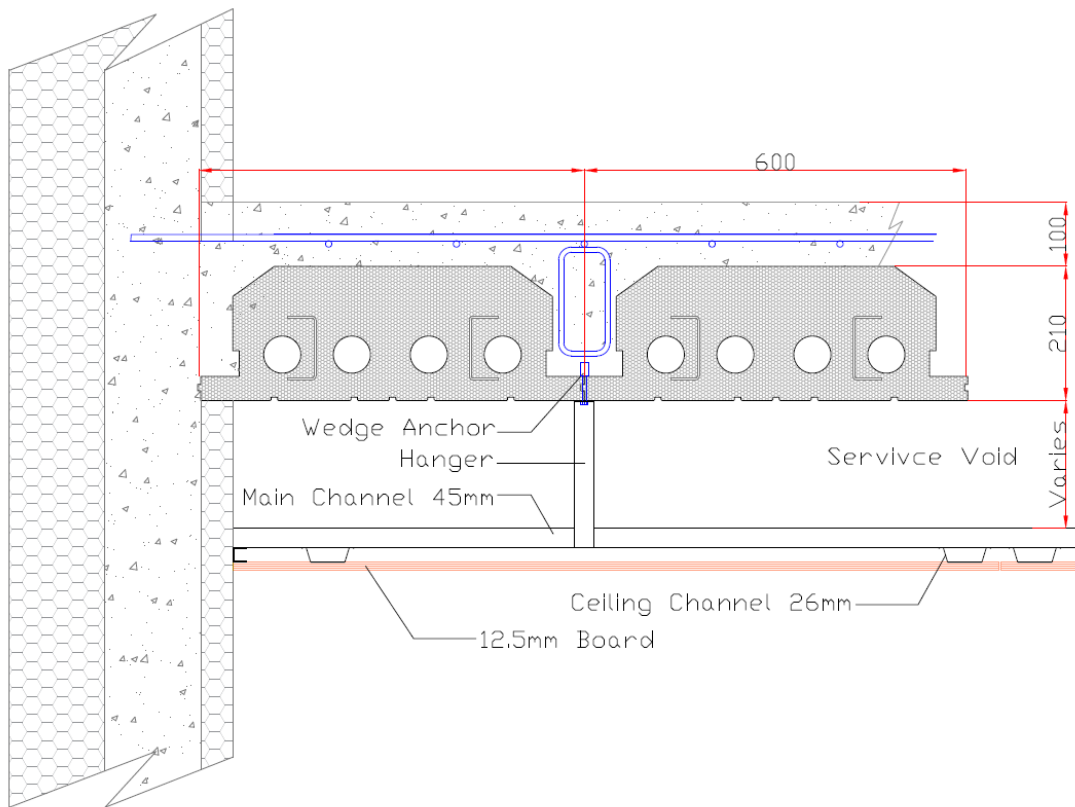

TF22 - Typical 210mm Thermofloor suspended floor build up



Hanger fixing & typical service void in suspended ceiling.

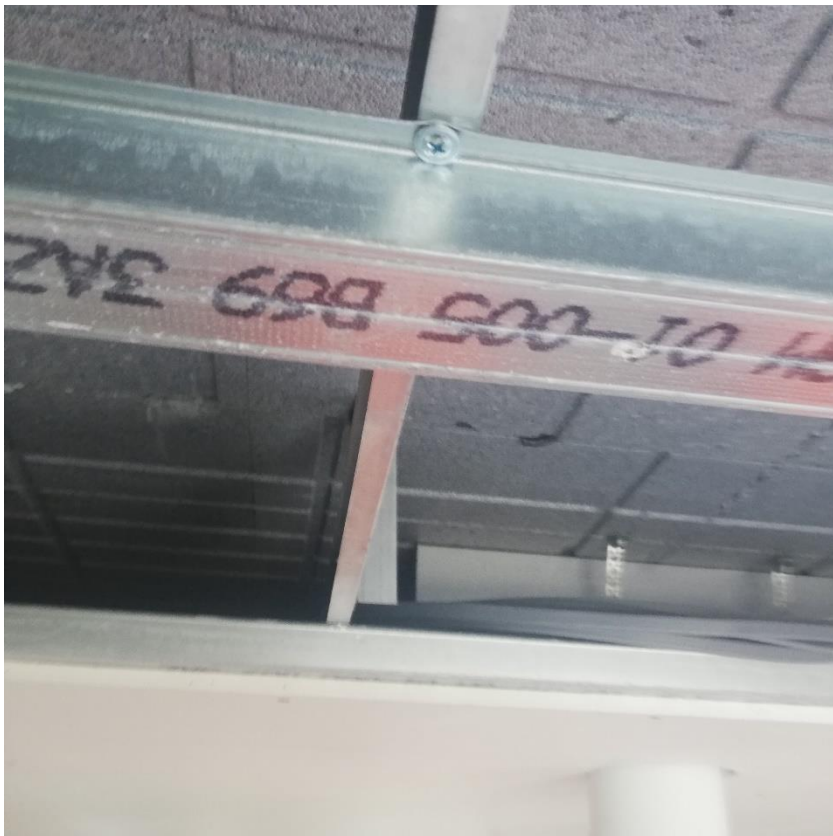



Other solutions using ThermoFloor

There are scenarios in which the ThermoFloor is employed, but the construction design necessitates adjustments to align with specific requirements. Here are a couple of instances where the ThermoFloor has been employed and tailored to accommodate the construction without altering the design or sacrificing performance.

However, it's important to note that the system's versatility extends beyond these two examples. Design engineers have the flexibility to explore the ThermoFloor system to create new solutions tailored to their unique construction needs.

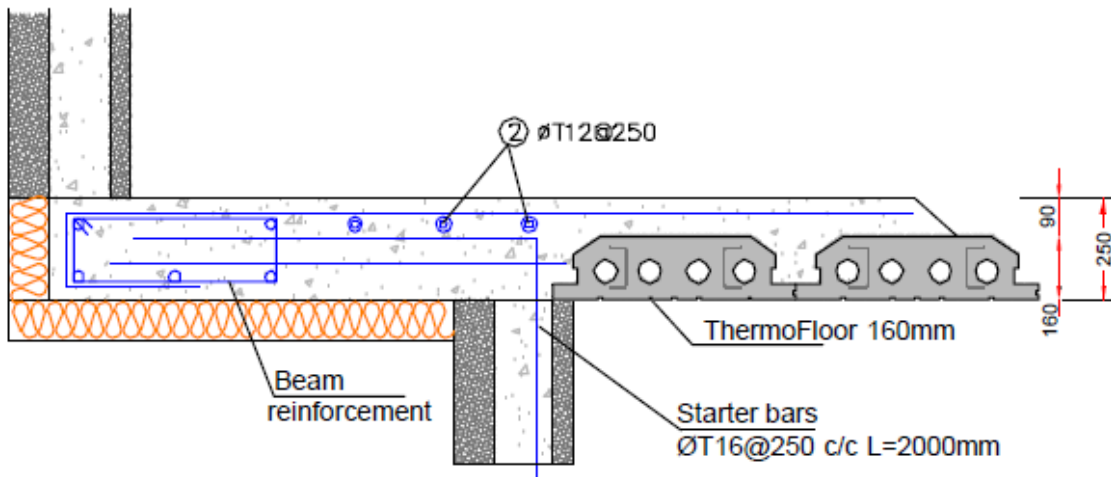

TF12a - Cantilever Floor

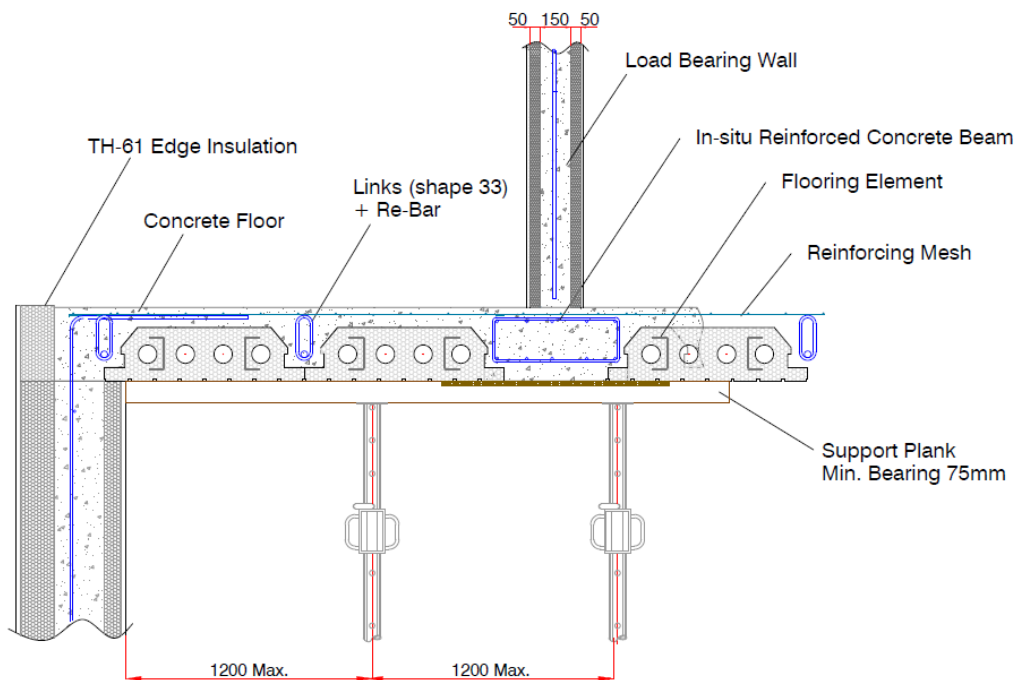

TF12b - In-situ Floor Beam

Thermofloor Acoustics

The Thermofloor system has been successfully applied in numerous projects, meeting the essential Airborne and Impact acoustic test criteria as specified by building regulations. A sample of comprehensive test results from a finished project is available in [the annex section](#) at the end of this document.

To enhance Impact acoustic performance, it is recommended to incorporate an impact mat on the concrete surface before surfacing the floor finish, contributing to the attainment of the desired results.

Pre-Cast Floors (Hollowcore)

Pre-cast flooring systems (also known as Hollowcore) are manufactured in a factory, often pre-cut to size, and then transported to the construction site where they are lifted into position using a crane. Site safety procedures must be followed when using this type of flooring on site.

These floors are typically pre-tensioned using steel cables embedded in the concrete to achieve exceptional strength. Pre-cast floors offer rapid installation and the capability for extensive unobstructed spans.

In the Thermohouse construction process, the walls are built to the desired height, and the pre-cast floors are placed directly onto the solidified concrete wall, as illustrated below diagrams.

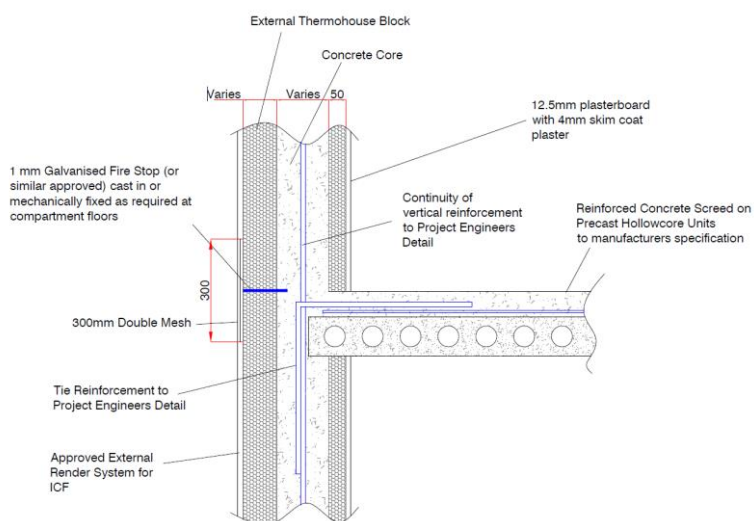

TF13 - Typical Precast Floor Detail (on external wall)

Notes to consider:

1. Screed & mesh Specification (Where Applicable) are the responsibility of the pre-cast manufacturer or design engineer
2. Minimum bearing of the precast slab should be as per the manufacturer's recommendations
3. All Laps and anchorage of reinforcing bars to be 50x bar diameter or as per design engineers specified requirements

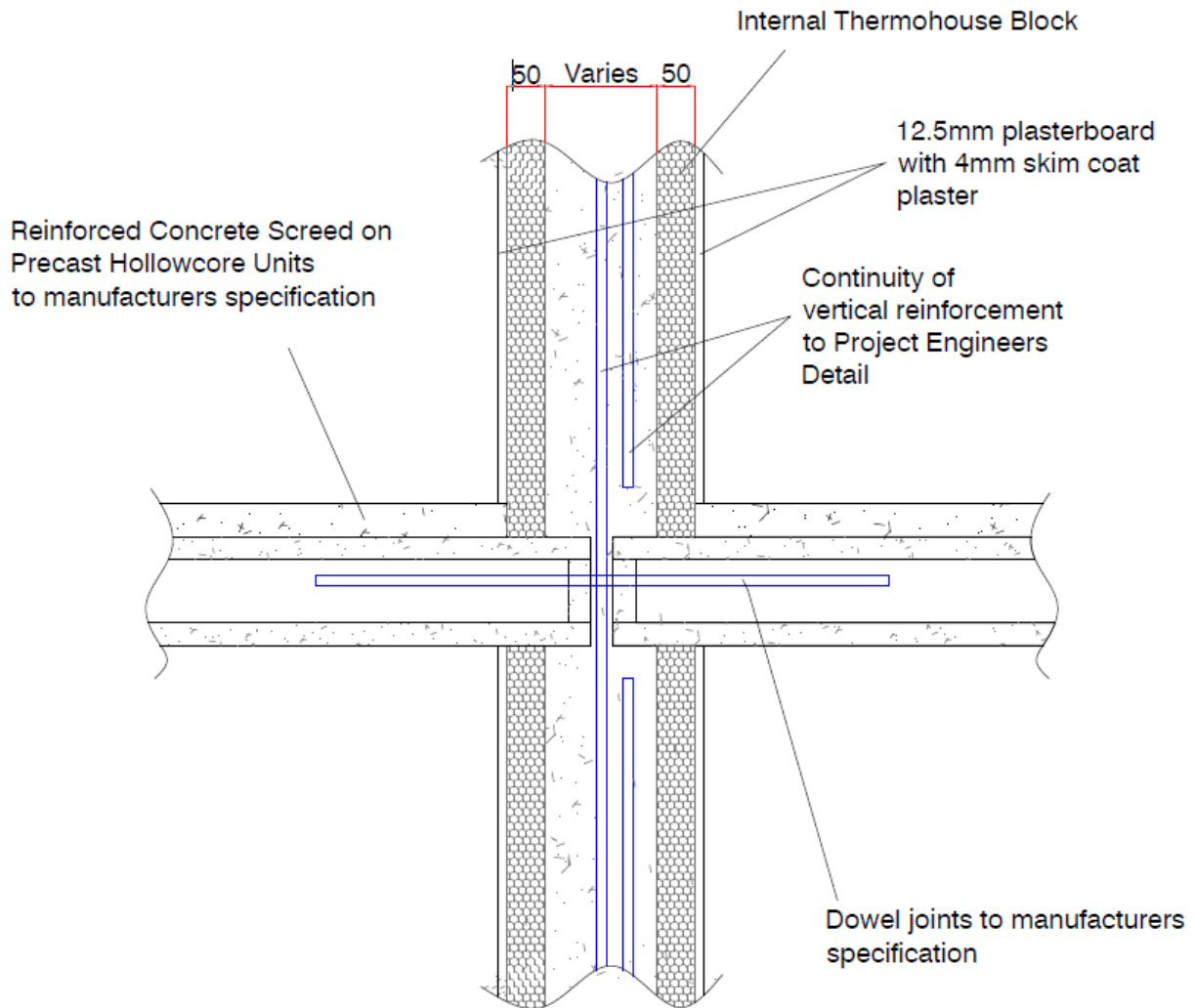

TF14 - Typical Precast Floor Detail (on internal wall)

Notes to consider:

1. Screed & mesh Specification (Where Applicable) are the responsibility of the pre-cast manufacturer or design engineer
2. Minimum bearing of the precast slab should be as per the manufacturer's recommendations
3. All Laps and anchorage of reinforcing bars to be 50x bar diameter or as per design engineers specified requirements.

Block & Beam

Block and beam flooring is a widely utilised system, often preferred due to its ready availability from local suppliers.

It can also be integrated with the Thermowall ICF system, provided that the manufacturer's recommendations are adhered to.

The primary advantage of the Beam & Blocks approach is its accessibility. The components are typically standard sizes designed for specific spans, and they can be easily assembled on-site.

However, compared to the Thermofloor system, Block and Beam can be relatively time-consuming to install and may require substantial lifting efforts. For upper floors, safety measures are typically needed, and additional insulation may still be necessary.

The following diagrams illustrate typical applications of the block and beam system, one with ICF as the substructure and the other with brickwork as the substructure.

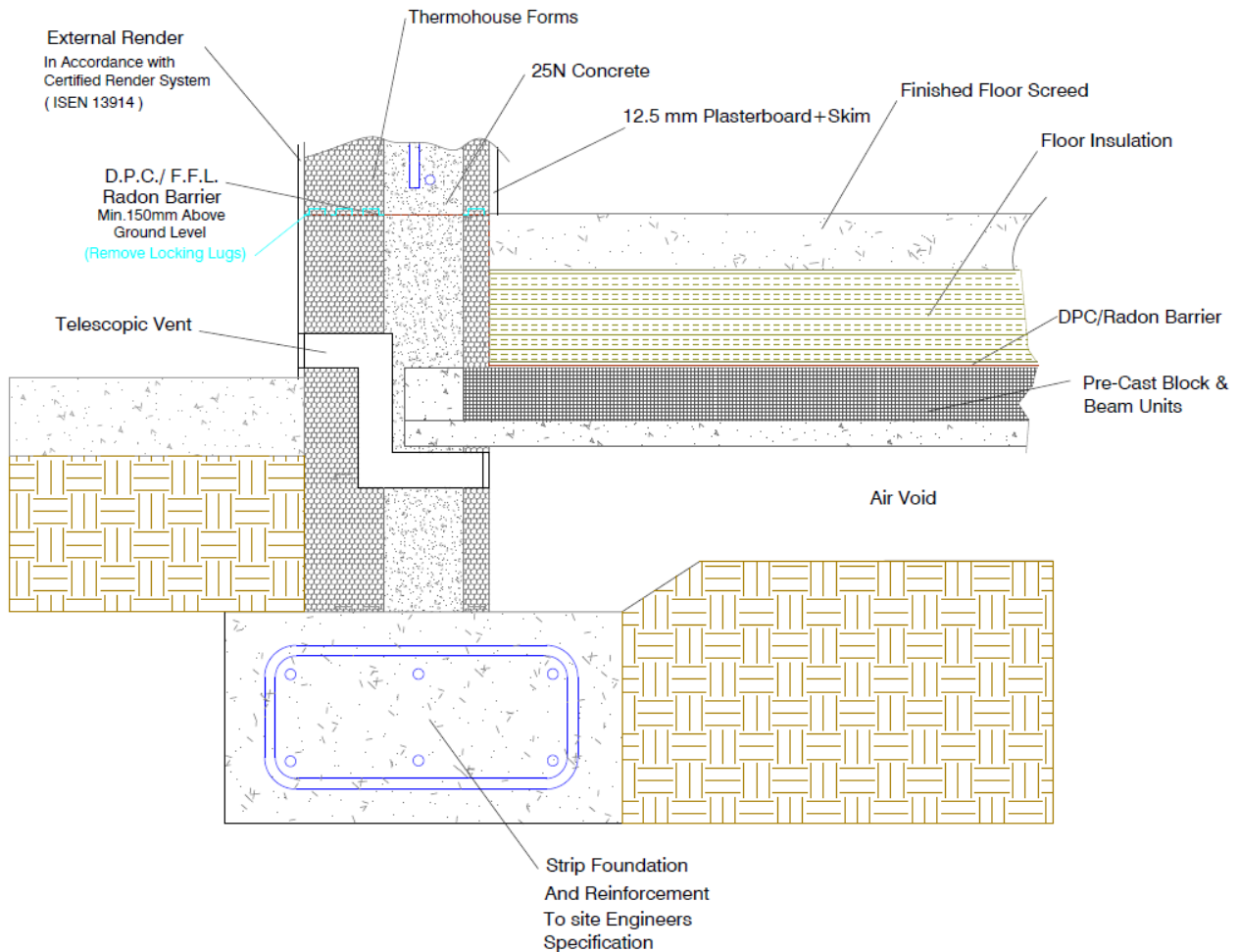

TF15 - Typical Block & Beam Floor Detail (on Thermowall blockwork wall)

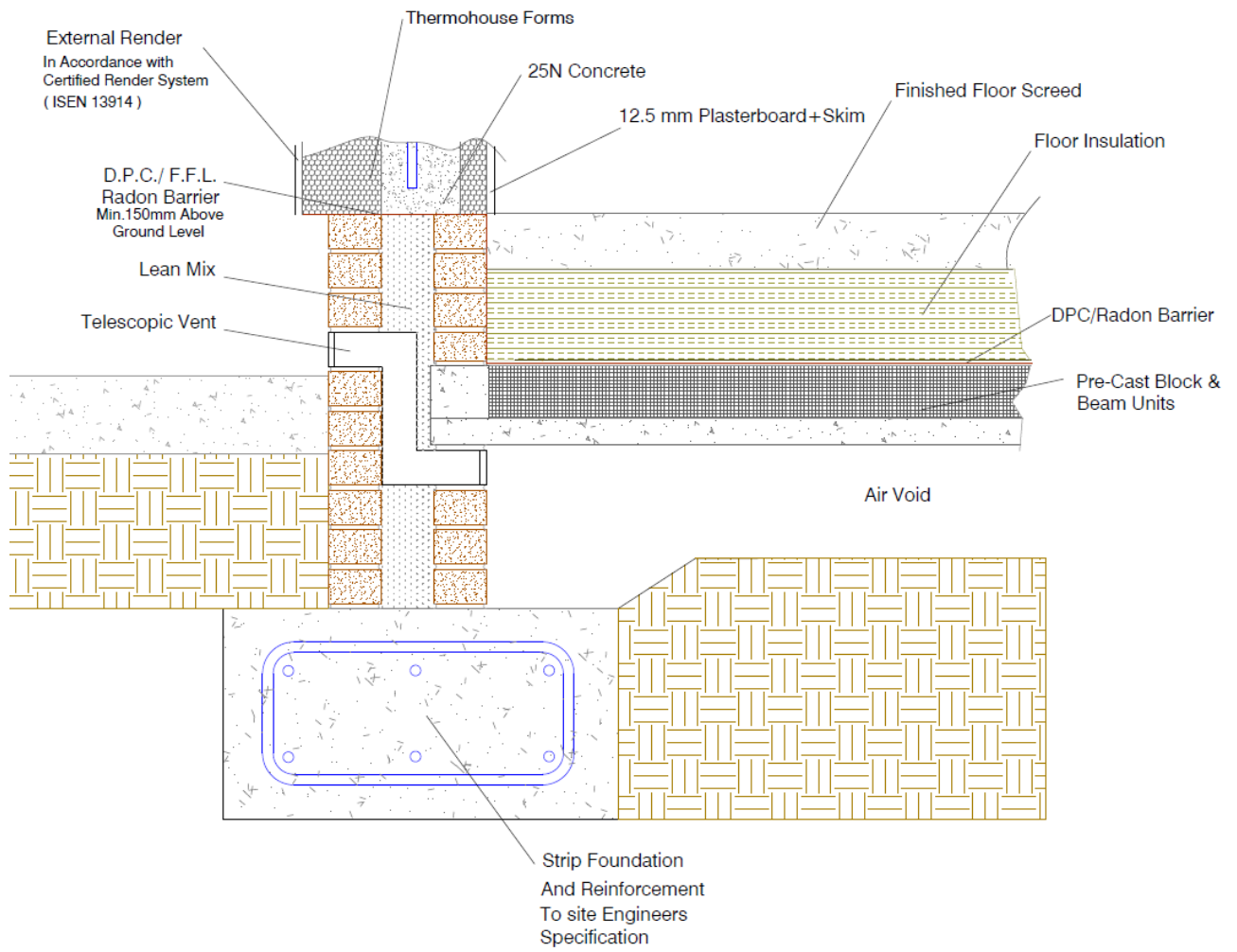

TF16 - Typical Block & Beam Floor Detail (on Brickwork wall)

Composite Metal Deck Flooring

The metal decking system is an innovative flooring solution widely used in construction. Comprising profiled steel sheets, it offers exceptional strength and durability for building floors. Its unique design enables rapid installation, reducing construction time and costs.

Additionally, metal deck system enhances structural stability and fire resistance, ensuring safer and more resilient buildings.

This versatile system is favoured for its adaptability to various architectural designs and its ability to create robust, long-lasting floors in both commercial and industrial settings.

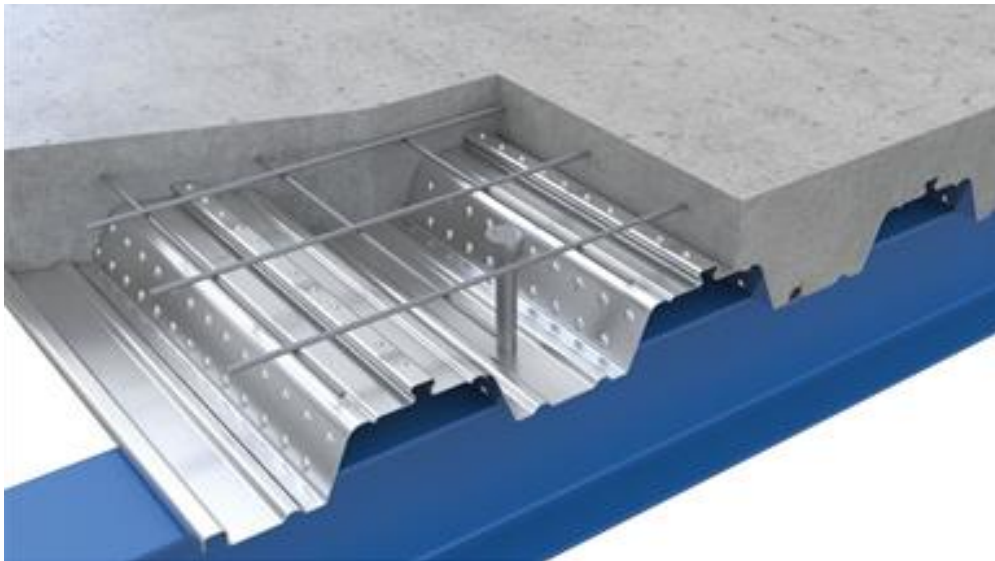

Metal Deck Floor System

Image source: Tata Comflor (similar products from other manufacturers may be used)

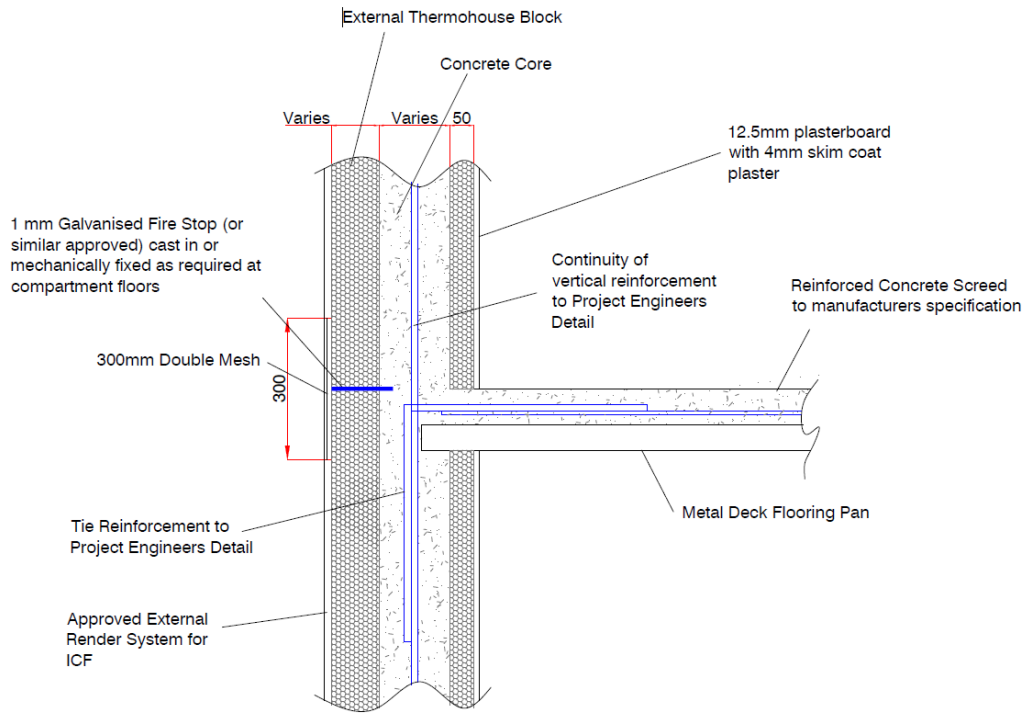

TF17 - Typical Metal Deck Floor Detail

Notes to consider:

1. Screed & mesh Specification (Where Applicable) are the responsibility of the pre-cast manufacturer or design engineer
2. Minimum bearing of the precast slab should be as per the manufacturer's recommendations
3. All Laps and anchorage of reinforcing bars to be 50x bar diameter or as per design engineers specified requirements.
4. The choice of metal deck type, size, and profile should be based on a thorough review of the manufacturer's technical specifications. The design engineer is responsible for approving the ultimate system configuration.

Suspended Timber Floor

When considering suspended timber floor systems for use with Thermowall, traditional timber joists, web joists, and I-Joist (also known as I-beams) can all be utilised. Each type has distinct applications, but the installation principles with ICF walls remain consistent.

Timber systems are readily available at local builders' merchants and can be cut on-site for installation flexibility. They typically require less space and, in the case of web joists, allow for service routing through the joists.

However, drawbacks may include longer installation times, difficulties in wet weather, increased weight, and potential warping or bending issues that can arise later in the construction process.



Traditional Timber Joist



Timber Web Joist

Image source: Pasquill (similar products from other manufacturers may be used)



Timber I-Joist (I-Beam)

Image source: Pasquill (similar products from other manufacturers may be used)

Please note:

All walls should be prepared and shuttered during the erection stage before the concrete pour to facilitate the intended fixing system for the trimmers/joists.

Preparation for face fixing:

Mark the centre of the ledger and core/cut 100-150mm holes at specified centres through the internal 50mm EPS, adequately shutter face of wall to form the fixing corbal for the trimmer.

Here are the steps for installing timber floor systems with Thermohouse blocks:

Face fixing ledger : Securely attach rim joists or ledgers to the concrete corbals previously set-out in the wall using anchor bolts either pre-fixed or post fixed. The size and spacing (determined before concrete pour) of these bolts should be specified by the Structural Engineer.

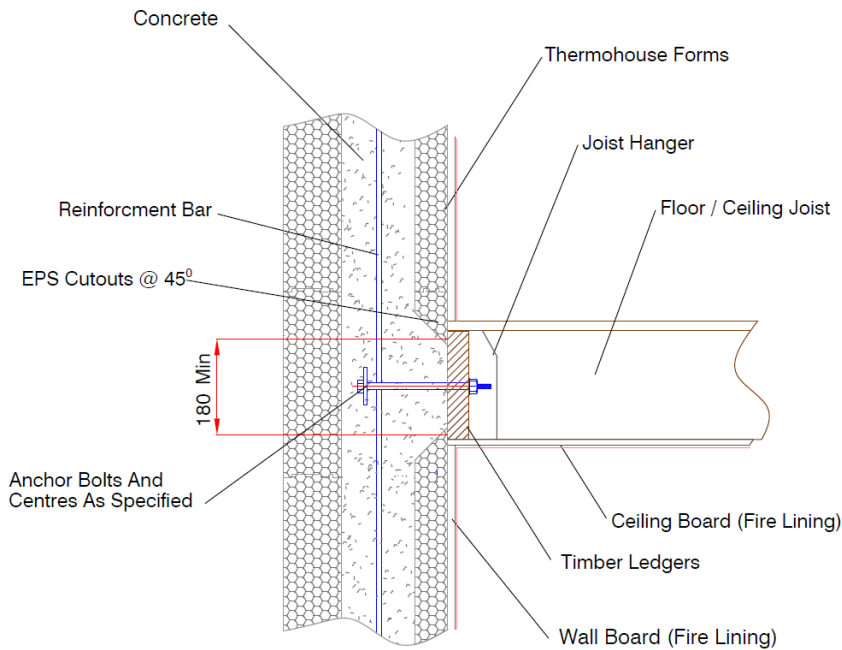

TF18a - Option 1 Cutout Corbals @ Secified Centres

Inset Ledger: Pre-fit joist hangers to ledger and install with retaining fixings as a wall shutter.

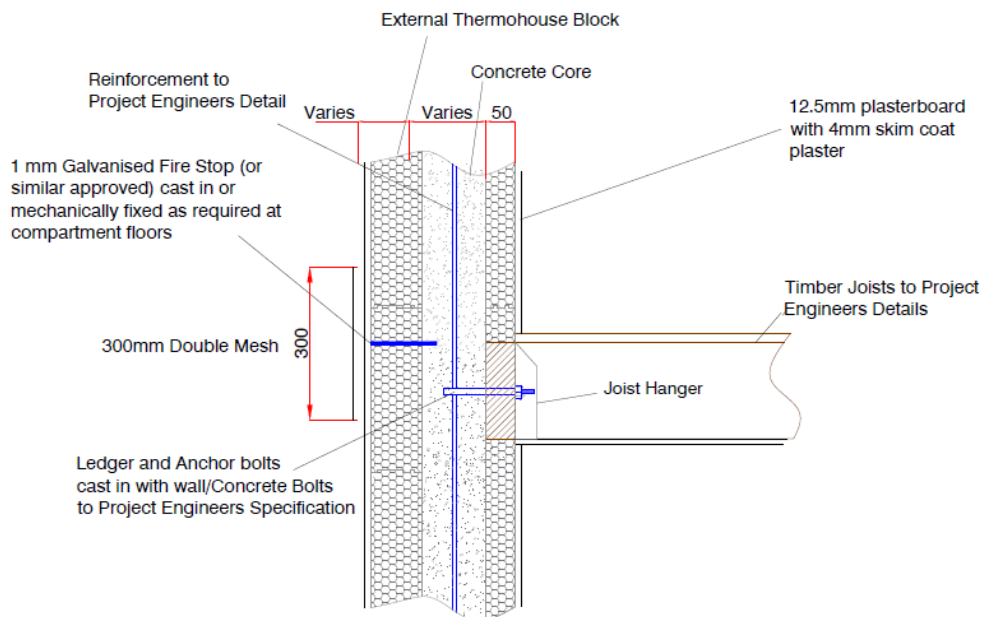

TF18b - Option 2 inset Ledger fixed in-line with blocks as shutter

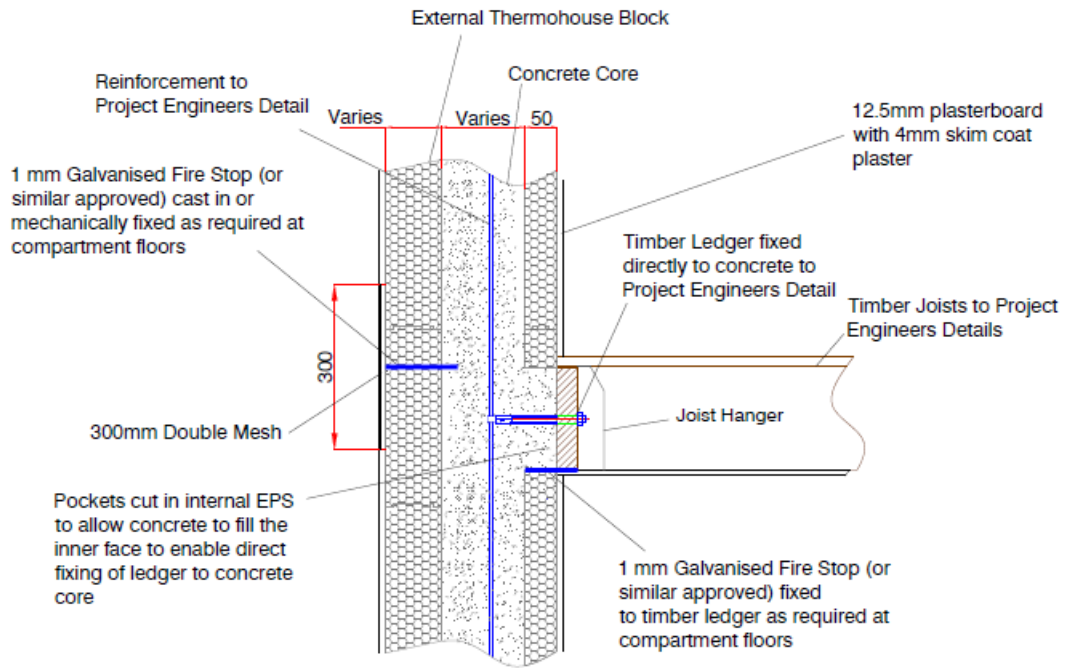

TF18c - Option 3 Ledger fixed in front of blocks

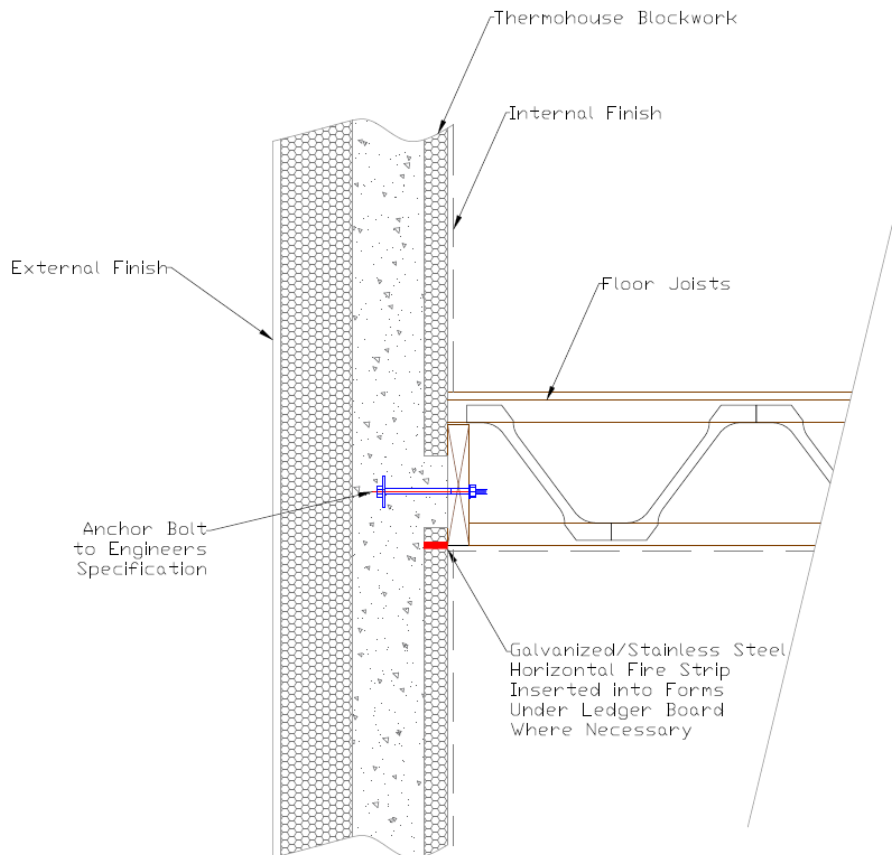

TF18d - Typical Ledger detail using Web joist or I-Beams

Metal Ledger fixings

The use of standard joist hangers to fix the floor joists. Alternatively, you can use the trimmer as the wall shutter with pre-hung joist hangers already in place. Proprietary joist hangers, like McMillan Joist Hanger or Simpson Strong-Tie (or any approved system), are designed for supporting wooden floor joists to ICF walls. Follow the manufacturer's instructions for proper installation.

ICF Metal Ledger Hanger Systems offer a robust solution for attaching ledgers to Insulating Concrete Forms (ICF) securely. These systems are versatile and can be tailored to fit specific design requirements. As illustrated in the diagrams below and detailed in Step 8 on the previous page, they ensure proper ledger attachment following manufacturer-recommended installation methods.

These systems come in various types and are supplied by different manufacturers, providing flexibility for design teams to select the product that best aligns with their project goals. It's essential to carefully consider the most suitable product for achieving your specific design objectives.

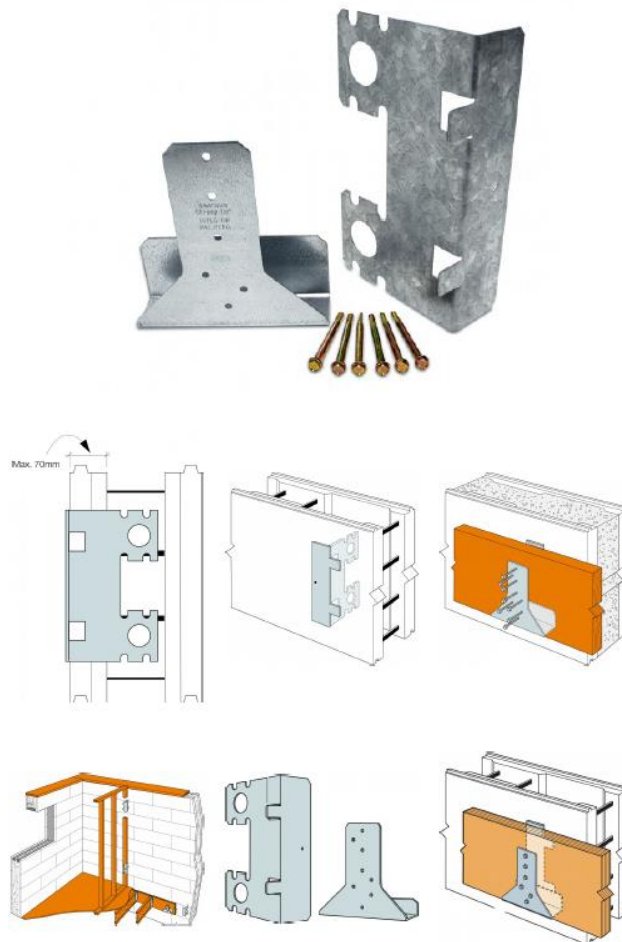

Typical Metal Ledger System

Image source: Simpson Strong-Tie (similar products from other manufacturers may be used)

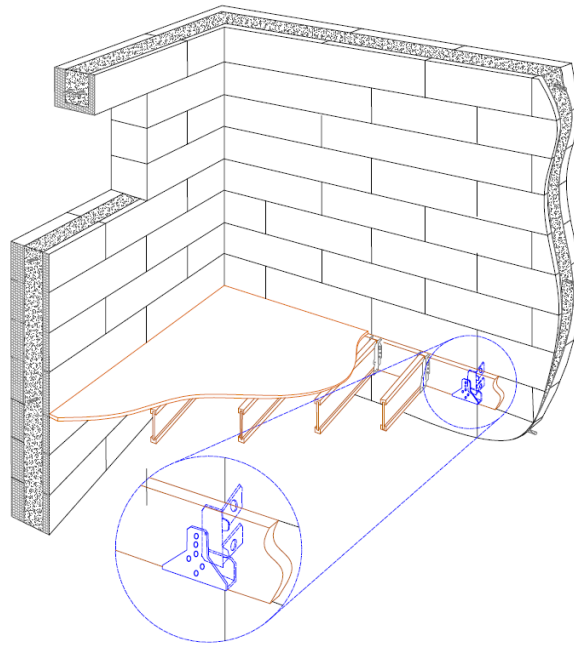

TF19 - Typical Metal Ledger System Detail

Thermofloor – As a flat roof

The Thermofloor 210mm, when paired with the TH-59 "T" beam insert, can serve as a concrete flat roof system. It's crucial to emphasize, as illustrated in the figures below, that the equivalent of a minimum of 60mm mineral wool insulation (thermal conductivity 0.040) should be placed on the concrete beneath the surface finish (done by others). **This insulation is required and prevents the formation of interstitial condensation on the internal surface.**

The depth of the slab will vary depending on spans and load requirements for the roof's intended use. To create a slope, you can either incorporate it into the concrete during installation, which may be challenging, or use firing battens placed on top of the cured concrete to achieve the desired slope.



210mm Thermofloor flat roof construction showing "T" Beam insulated Inserts & Reinforcements

Below are a couple of typical build up diagrams.

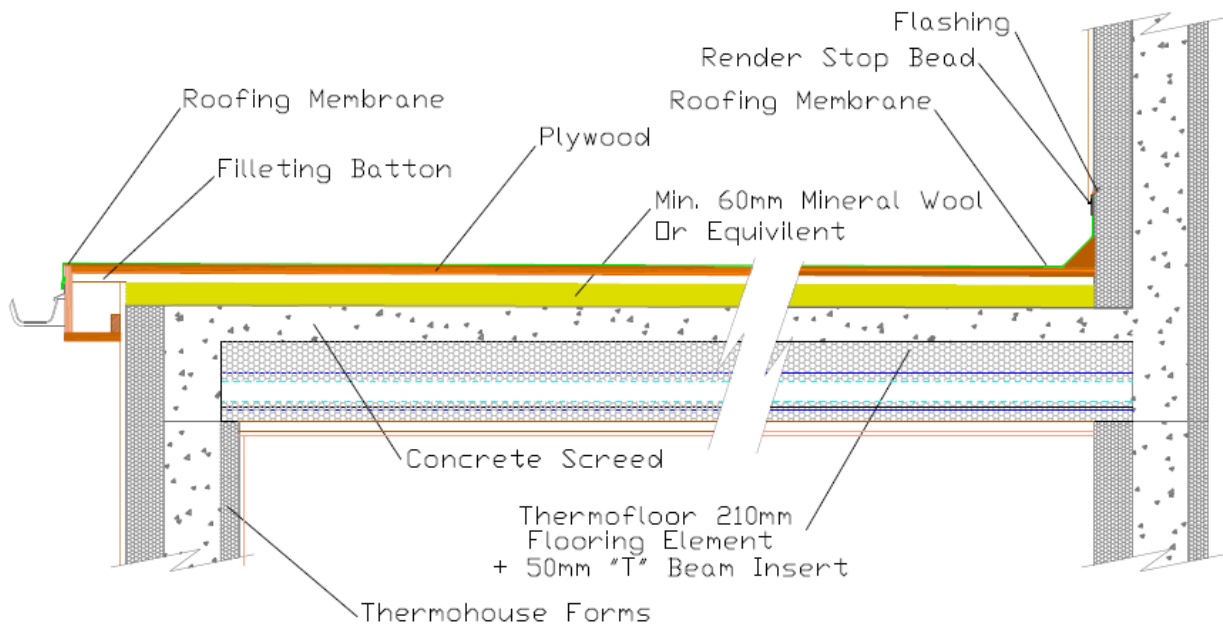

TF20a - Typical 210mm Thermofloor flat roof (open edge) Detail

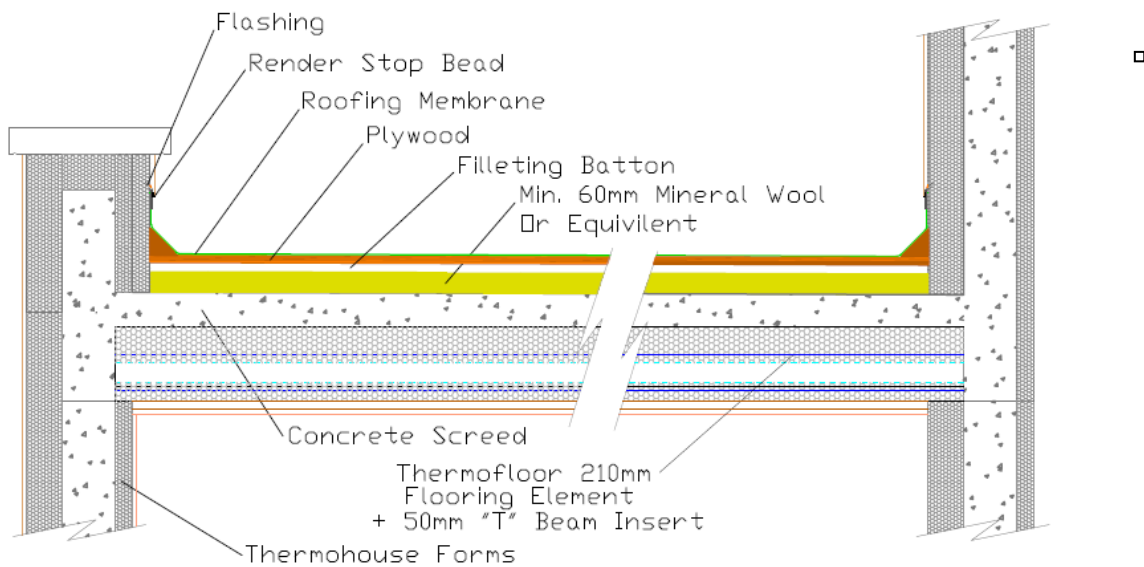

TF20b - Typical 210mm Thermofloor flat roof (Parapet Wall) Detail

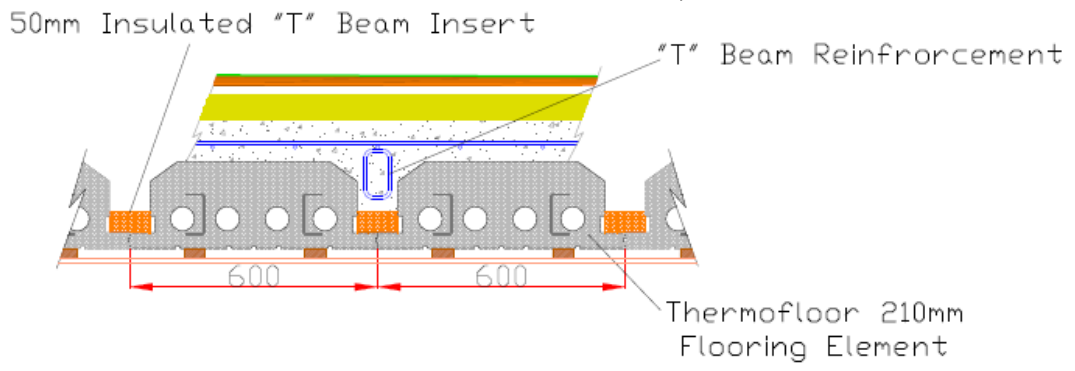

TF20c - Typical 210mm Thermofloor flat roof section Detail

210mm Thermofloor used in external balcony



Under intermediate floor Slab - Services

Electrical Installation

Electrical installations are typically done after pouring concrete. However, if needed, conduits that pass through the floor should ideally be installed or sleeved before concrete placement to avoid the need for core boring later.

For secure attachment, tracks and conduits can be screw-fixed to the "C" sections within the Thermofloor panels. These panels have a longitudinal groove at approx. 250mm centers on their underside to guide the screw placement. Additionally, the concrete "T" beam can be utilised as an alternative attachment point for drop ceilings etc.

Please note that PVC cables must be placed inside conduits to prevent any adverse reactions with the EPS. Therefore, it's essential to ensure that PVC cables do not come into direct contact with the EPS.

Various tools can be used to create channels and spaces for wiring and electrical boxes, including a hot knife, different types of hand saws, or a router.

Lastly, it's crucial to adhere to all relevant electrical regulations and standards when performing electrical wiring works with EPS.



Suspended ceiling showing service void

MVHR Ducting / Plumbing & other services

In the majority of cases, building designs are intended to avoid routing plumbing pipes through the Thermofloor panels, except for specific utility entry and exit points or engineered openings designed for this purpose.

Typically, pipes are situated within the service void located between the floor panel and the false ceiling. If additional space is needed, it is feasible to remove the EPS material between the "C" sections after the structural concrete floor above has fully cured (28+days).

Many Mechanical Ventilation & Heat Recovery (MVHR) units utilise plastic ducts, which are often routed within these service voids. It's crucial to engage in early discussions with the manufacturer of the selected units to obtain duct sizing information during the design stage. This ensures adequate space allocation, as these ducts may traverse through the voids and floors, necessitating pre-planned service points.



Suspended ceiling showing Services running in void



Thermohouse development in Killarney



Thermohouse development in Killarney



the complete low energy building system

Thermorooof

Thermorooft Elements

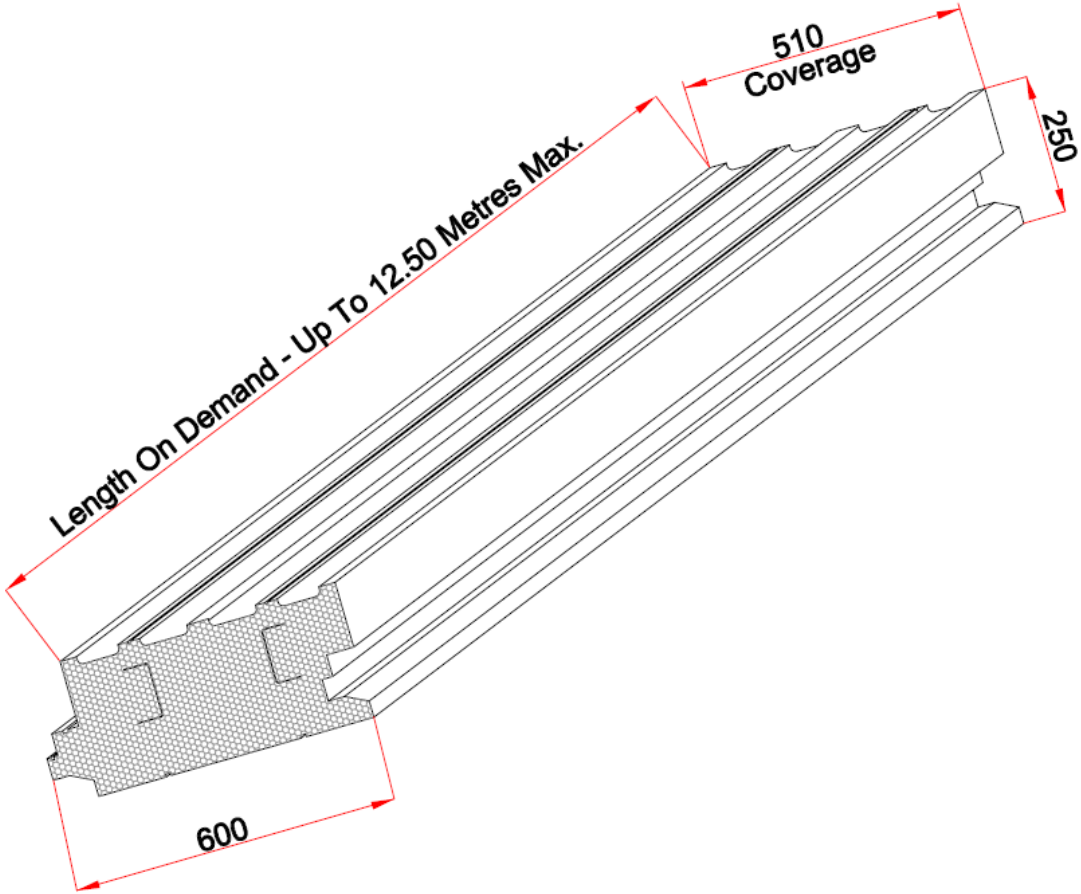

TR1 – Roof Element

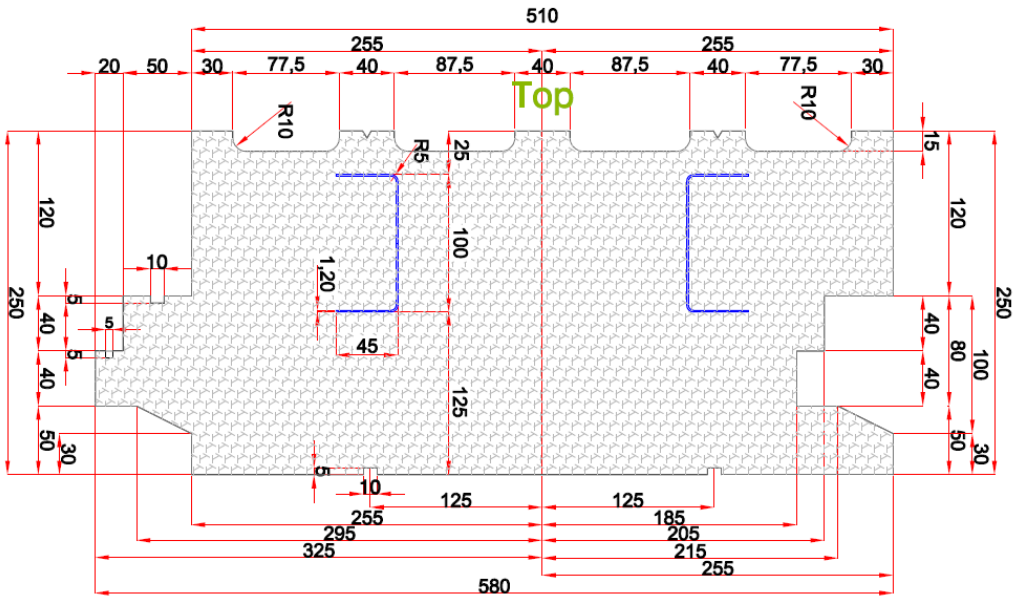

TR2 – Roof Element

Thermorooft 



The Thermorooft insulated roof panel is produced from EPS and has two galvanized steel C-sections running through its length. Panels are manufactured to length and only require intermediate support .
Panels can be used to suit any design or finish, whether A-shaped, flat, mono-pitched or curved. For pitched roofs panels span from wall plate to ridge beam. For curved roofs, panels span gable to gable.

Size (H x W)	Max Length	Weight
250mm x 510mm	10000mm	13.4kg/m ²

Technical	
Thermal Conductivity (EPS)	0.030W/mK
Density	24kg/m ³
U-Value Rating	0.150W/m ² K

Certifications & Ratings	
Certifications	ETA, IAB, NSAI
External Fire Spread	Class 0

Materials	
EPS & Steel C-Sections	

Commercial	
Typical Use	Pitched double & single span roof



Design according to EN1991-1-4:2005 and associated National Annexes

TABLE 1A - MAXIMUM SPAN FOR A SINGLE SPAN ROOF							
ROOF FINISH	WIND LOAD TYPE	ROOF SLOPE					
		10°	20°	30°	40°	50°	60°
SPAN (m)							
SLATES	EXPOSURE 1	3.30	3.30	3.30	3.30	3.30	3.30
	EXPOSURE 2	3.30	3.30	3.30	3.30	3.30	3.30
	EXPOSURE 3	3.50	3.50	3.50	3.50	3.50	3.50
	EXPOSURE 4	3.70	3.70	3.63	3.70	3.70	3.70
TILES	EXPOSURE 1	3.10	3.10	3.10	3.10	3.10	3.10
	EXPOSURE 2	3.25	3.25	3.25	3.25	3.25	3.25
	EXPOSURE 3	3.40	3.40	3.40	3.40	3.40	3.40
	EXPOSURE 4	3.50	3.50	3.50	3.50	3.50	3.50

Table 1B - MAXIMUM SPANS FOR A DOUBLE SPAN ROOF							
ROOF FINISH	WIND LOAD TYPE	ROOF SLOPE					
		10°	20°	30°	40°	50°	60°
SPAN (m)							
SLATES	EXPOSURE 1	3.20	3.20	3.20	3.20	3.20	3.20
	EXPOSURE 2	3.20	3.20	3.20	3.20	3.20	3.20
	EXPOSURE 3	3.40	3.40	3.40	3.40	3.40	3.40
	EXPOSURE 4	3.50	3.50	3.50	3.50	3.50	3.50
TILES	EXPOSURE 1	2.95	2.95	2.95	2.95	2.95	2.95
	EXPOSURE 2	3.00	3.00	3.00	3.00	3.00	3.00
	EXPOSURE 3	3.20	3.20	3.20	3.20	3.20	3.20
	EXPOSURE 4	3.30	3.30	3.30	3.30	3.30	3.30

TABLE 2 - THERMOROOF PANEL PROPERTIES

THERMOROOF PANEL	Moment Capacity	5.84 kNm/m
	Moment of Inertia	119.2 cm ⁴ /m

TABLE 3 - LOAD SUMMARY FOR ANALYSIS

SLATED ROOF PERMANENT LOAD		TILED ROOF PERMANENT LOAD	
Slates (15mm avg tk x 30kN/m ²)	0.45 kN/m ²	Tiles (35mm avg tk x 20kN/m ²)	0.70 kN/m ²
Thermorooft panel	0.12 kN/m ²	Thermorooft panel	0.12 kN/m ²
Battens and felt	0.05 kN/m ²	Battens and felt	0.05 kN/m ²
Ceilings and services	0.25 kN/m ²	Ceilings and services	0.25 kN/m ²
TOTAL PERMANENT:	0.87 kN/m²	TOTAL PERMANENT:	1.12 kN/m²
WIND LOAD		OTHER LOADS	
Exposure 1	1.78 kN/m ²	Imposed (Repair and maintenance)	0.80 kN/m ²
Exposure 2	1.88 kN/m ²	Snow (Basic)	0.80 kN/m ²
Exposure 3	1.41 kN/m ²		
Exposure 4	1.18 kN/m ²		

NOTES AND ASSUMPTIONS:

1. Site orography not significant.
2. Relevant only to structures less than 250 m OD Main Head.
3. Wind load types:
 - Exposure 1 - Refers to basic wind speed of 26 - 27 m/s .
 - Exposure 2 - Refers to basic wind speed of 25 - 26 m/s.
 - Exposure 3 - Refers to basic wind speed of 23 - 24 m/s.
 - Exposure 4 - Refers to basic wind speed of 22 m/s or less.
4. The span is measured along the slope of the roof and double span panel assumed. If single span panel is proposed, consult the certificate holder.
5. Steel grade to be minimum S275.
6. Spans are calculated with deflection limits of L/200 (no ceiling). For roofs supporting ceilings which require stricter deflection criteria, consult the certificate holder.
7. For basic ground snow loads greater than 0.6kN/m² and/or combined with the presence of snow drifts, consult the certificate holder.
8. For other load conditions outside the scope of these tables, consult the certificate holder.

Thermorooft Application

The Thermohouse Roofing System is certified for utilisation in a wide range of building types, encompassing both residential and commercial structures, regardless of the roof pitch. This versatile system is suitable for various roofing styles, including traditional, flat, and curved roofs.

The system has undergone rigorous assessment to ensure its suitability as load-bearing roofing panels, which can be conveniently supported by wall plates, ridge beams, and intermittent purlins (dependent on span). These panels can be employed in single or multiple spans, depending on the specific project requirements.

In essence, the roof panels function as conventional roof rafters in traditional roof constructions, relying on primary support elements like purlins and steel beams, if the span requires same. It is imperative that the primary roof structure is engineered to withstand all wind uplift forces.

It is essential to note that all designs and applications must receive final approval from the Supervising Engineer to guarantee their structural integrity and safety.

Thermorooft Design

The Thermohouse Roofing System comprises two steel cold-formed "C" sections enveloped within molded panels made of expanded polystyrene (EPS) and will span 4.0m. These panels securely interlock thanks to their tongue-and-groove profiles. To ensure a robust seal, the vertical tongue-and-groove joints are bonded using low-expansion adhesive foam during installation. Each individual panel is firmly anchored by fastening it through the two cold-formed "C" sections to timber wall plates, purlins (or knee walls), and ridge beams.

The Thermohouse Roofing System panels are custom-manufactured to meet the specific pitch and length requirements of each project. Typically, the roof panels are crafted as one continuous unit, extending seamlessly from ridge to eaves. The practice of butt jointing panels or splicing them along their length is discouraged, unless such joints are positioned on a supporting beam. Each panel possesses an overall depth of 250mm and a width of 510mm. The dimensional tolerances for manufactured panels are as follows:

- Length: $\pm 0.6\%$
- Width: $\pm 2\text{mm}$
- Height: $\pm 2\text{mm}$

Additionally, the roof panels are mitred to accommodate plumb cuts at the eaves and ridge, ensuring a precise fit. For cutting the cold-formed sections, utilise either a "Large Blade Circular Saw" or a "Reciprocating Saw." After cutting, it is imperative to reinstate corrosion protection to the cut ends of all cold-formed sections. Exercise reasonable care to prevent any damage to the forms before, during, and after installation. Do not puncture, split, deform, or excessively compress the forms before their intended use.

The next page will show what a typical set out drawing for our roof panels looks like.

IT IS THE RESPONSIBILITY OF THE CLIENTS PROJECT ENGINEER TO DESIGN AND SPECIFY ALL THE STRUCTURAL ELEMENTS.

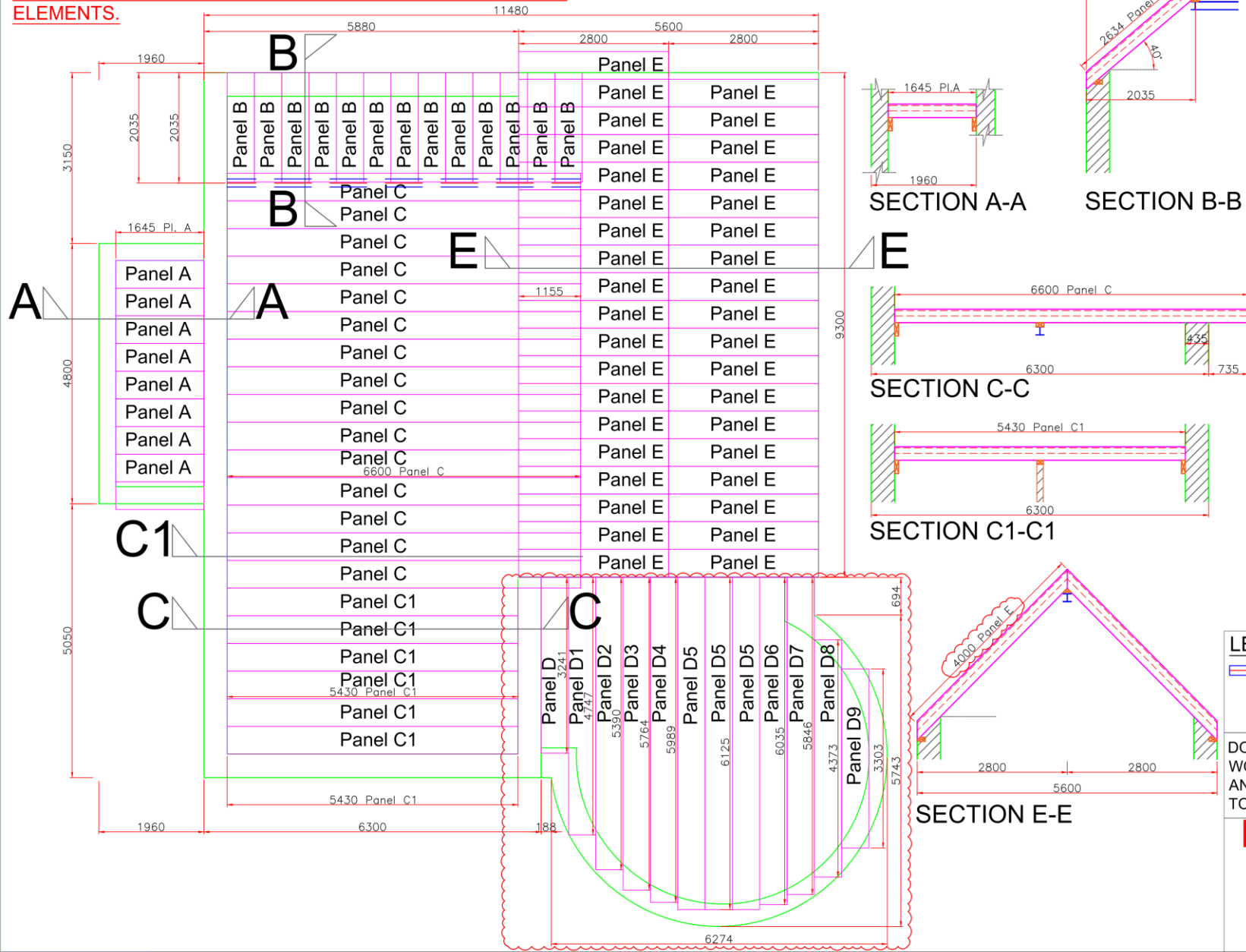

Roof Panel 250MM

Panel Ref.	No. of Panels	Panel Length	Pitch
A	8	1.645	0°
B	13	2.635	40°
C	16	6.600	0°
C1	6	5.430	0°
D	1	3.240	0°
D1	1	4.750	0°
D2	1	5.390	0°
D3	1	5.765	0°
D4	1	5.990	0°
D5	3	6.125	0°
D6	1	6.035	0°
D7	1	5.845	0°
D8	1	4.375	0°
D9	1	3.305	0°
E	37	4.000	45°

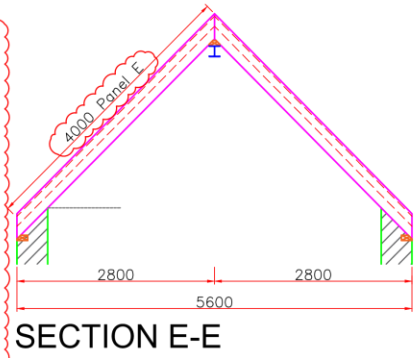
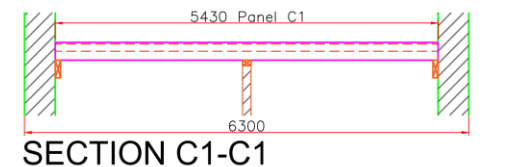
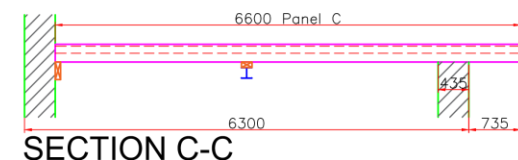
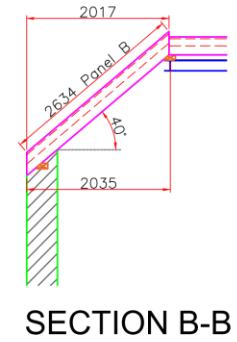
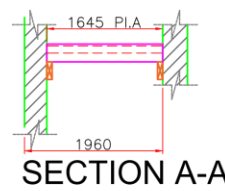

LEGEND
 Steel Beam
 (to be designed by clients structural engineer)

DO NOT SCALE FROM THIS DRAWING, WORK ONLY FROM FIGURED DIMENSIONS. ANY DISCREPANCIES OR OMISSIONS ARE TO BE REPORTED TO THE ENGINEER.

Provisional Layout

For Approval
 Name : _____
 Date : _____



Coolcastagh
 Killarney
 Co. Kerry
 Ireland
 Tel: 064 66 31307
 Email: info@thermohouse.ie
 Web: www.thermohouse.ie

This drawing to be read in conjunction with all other Thermohouse drawings and any other relevant information.
 No dimensions are to be scaled from this drawing.
 Unless noted otherwise, all dimensions are in millimeters and all levels are in meters from the noted datum.
 Copyright reserved.

2	Revised as per the clients comments	25.07.23	TK	FT	Client:
1	Addition of main pitched roof	14.07.23	TK	FT	
0	Produced for comment only	14.07.23	TK	FT	
Rev:	Description:	Date:	Drawn:	Checked:	Project:

Title: Roof Panel Set Out			
Scale: NTS	Sheet Size: A3	Date: 173	25-07-2023
Drawn By: TK	Checked By: FT	Drawing No:	Revision: 2

**To Cut - Use a Reciprocating Saw
With a Long Reach Blade
Suitable For Cutting "C" Section Steel Profiles**

**All Bevelled Cuts Should Be Carried Out At Ground Level
Before Positioning The Roof Panels And Before Installing
The Roofing Lath's.**

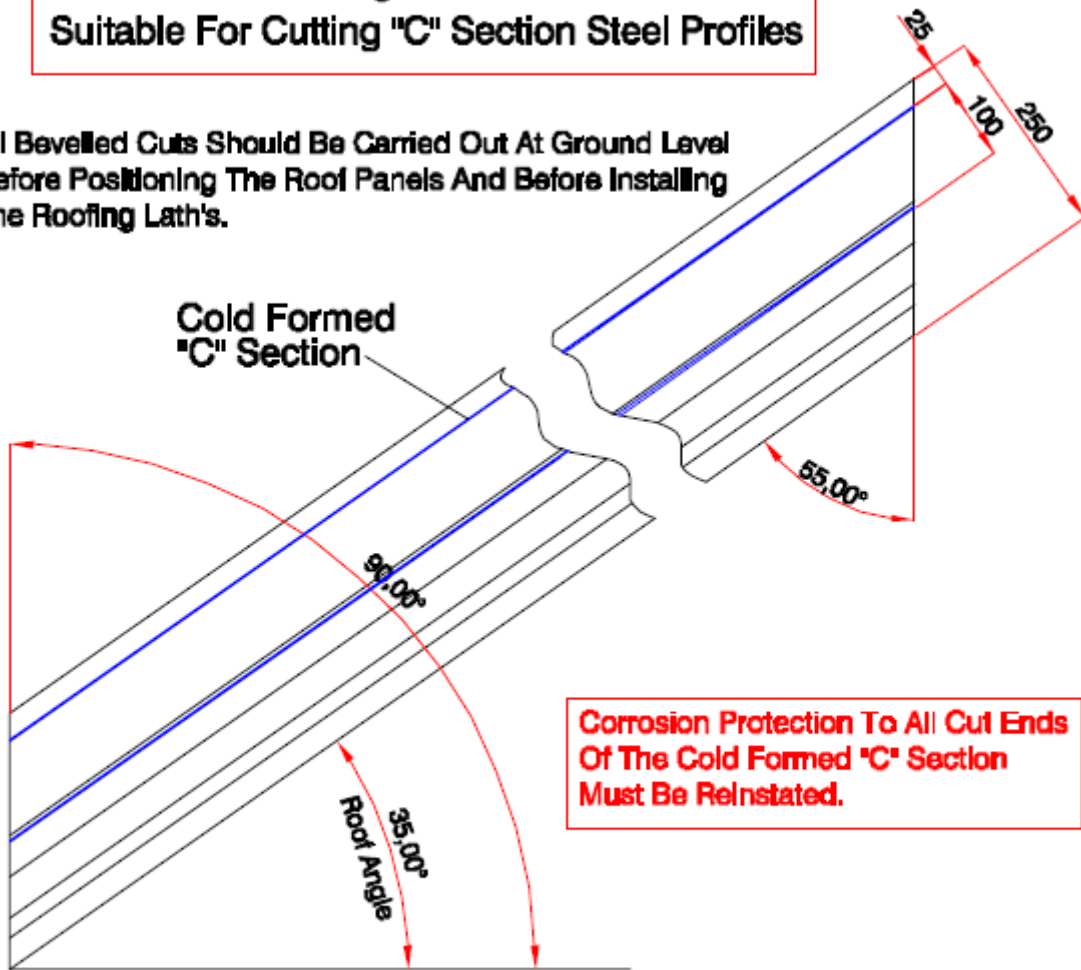

**All Cut Angles Should Be Measured
Relative To The Angle Of The Roof**

TR3 - Typical Beval Cut Detail

Tools Materials & Accessory requirements

Here's a checklist of materials, tools, and accessories required for the project:

Materials:

8mm x 275mm Panel Screw (Supplied)

6-8mm x 180mm Panel Screw (Supplied if required)

Ensure that when using the panel screws, they are driven through the "V" grooves on the panels, which indicate the location of the "C" sections embedded within the panel. Screws should be inserted perpendicularly (at 90 degrees) to the panel to achieve a 50mm embedment into the timber supports. If the screw needs to be driven at an angle other than 90 degrees, a longer screw will be necessary to ensure proper embedment. Best driven with an impact wrench, It may be necessary to punch the screw before driving.

Low Expanding Adhesive Foam (Supplied)

Expansion Foam

Weathering / Airtight Tape

Fixings for Battens, Wall Plates, Purlins

Ridge/Apex Straps (if required)

Timber Battens

Anchor Bolts

PVC Pipe Sleeves for Penetrations (If necessary)

Fire Stops (If necessary)

Vapour Control Layer (If necessary)

Breathable Vapour Barrier (Exterior)

Tools & Accessories:

Impact wrench (or similar)

Foam Gun

Large dia. Skill saw

or

Reciprocating saw

Long reach metal blade

Handsaw

Delivery, Storage & Marking

Please make sure to review the "**Delivery, Handling & Storage**" section in this manual for comprehensive details when working with Thermohouse panels. Upon delivery to the site, panels are securely strapped in bales, and all components are clearly labeled with their respective sizes and positions within the construction as shown in the Roof Panel Layout which is previously agreed.

Under normal storage conditions, Thermohouse Roof System components should not deteriorate, provided they are shielded from environmental exposure prior to usage. Storage should take place on stable, level, and dry ground. If components are to be stored outdoors, they must be safeguarded from adverse weather conditions by employing a secure covering. Additionally, it's crucial to protect Thermohouse Roof System materials from prolonged direct sunlight and prevent contact with plastic materials containing plasticizers or volatile, aggressive solvents.

Take special care to ensure that the polystyrene **does not** come into contact with any corrosive chemicals or harmful agents, such as diesel oil, petrol, various cleaning solvents, hydrocarbons, membranes with coal tar pitches, or building products containing solvents.

The lightweight panels are easily manageable on-site, and the EPS (expanded polystyrene) can be readily cut or trimmed using a knife or a fine-toothed saw.

For cutting the cold-formed sections, utilize either a "Large Blade Circular Saw" or a "Reciprocating Saw." After cutting, it is imperative to reinstate corrosion protection to the cut ends of all cold-formed sections. Exercise reasonable care to prevent any damage to the forms before, during, and after installation. Do not puncture, split, deform, or excessively compress the forms before their intended use.

The surface finish of the "C" sections consists of a Zinc coating designated as Z275, equating to 275 g/m² of Zinc coating on both the top and bottom surfaces of the hot-dipped galvanized steel coils. This ensures a minimum thickness of 15µm (microns) of zinc coating on each side of the cold-formed section.



Straight A-Line roof running gable to gable

Wall Plate

For easier understanding, please also consult the **"Wall Plate Connections"** section in this manual, which offers a detailed explanation of the correct installation procedure.

The Thermohouse Roofing panel must be supported exclusively by timber wall plates, ridge beams, and intermediate purlins (where necessary), generally formed from 150mm x 75mm with a single or double chamfer to suit. If any other forms of support, like masonry walls or steel beams, are used, a timber fixing beam with a minimum bearing width of 75mm must be securely affixed before installing the roofing panels or a suitable fixing in the circumstances.

Ensure that all timber wall plates are firmly anchored to withstand the specific regulatory design loads. The timber wall plates, purlins, and ridge beams should possess adequate depth to allow for a complete 50mm embedding of the holding down screws. To keep compressive forces on the EPS material within acceptable limits, all timber support beams must be chamfered to match the roof pitch and provide a minimum bearing width of 75mm, this is to counteract the compaction of the EPS. Bearing widths may be reduced in cases where the "C" section sits directly on the support, but designers should consult the certificate holder for guidance in such instances.

For support at gable ends, special T-fixings, as illustrated in the images below, may be necessary. In all situations, the wall plate must be securely anchored or strapped down before the installation of Thermohouse roofing panels.

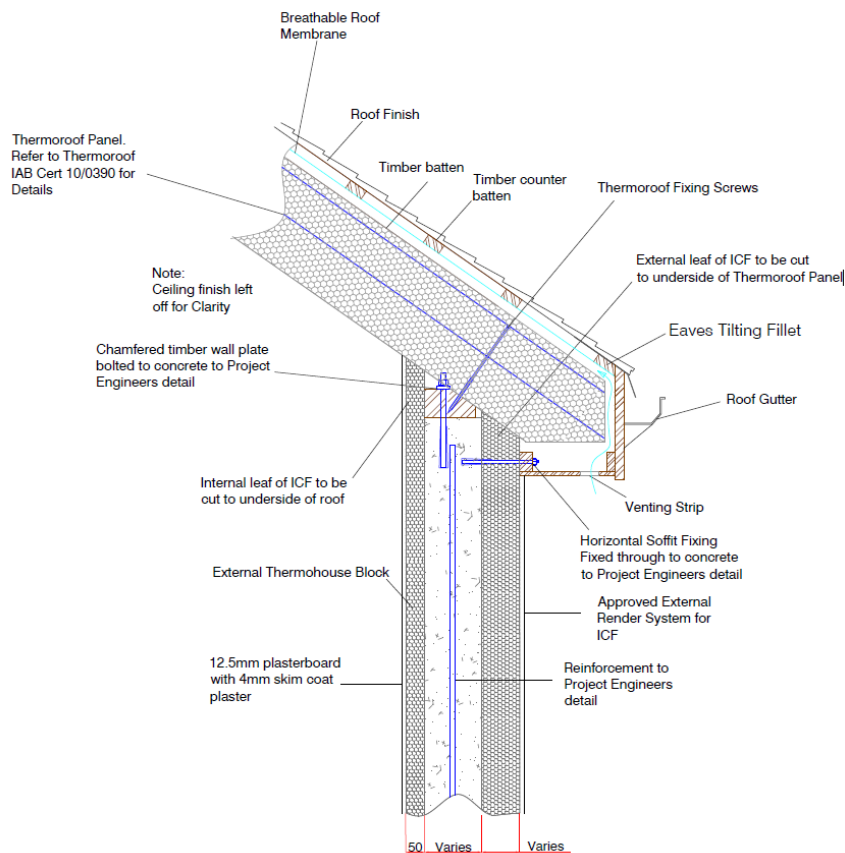

TR4 - ThermorooF to Thermowall Typical Detail

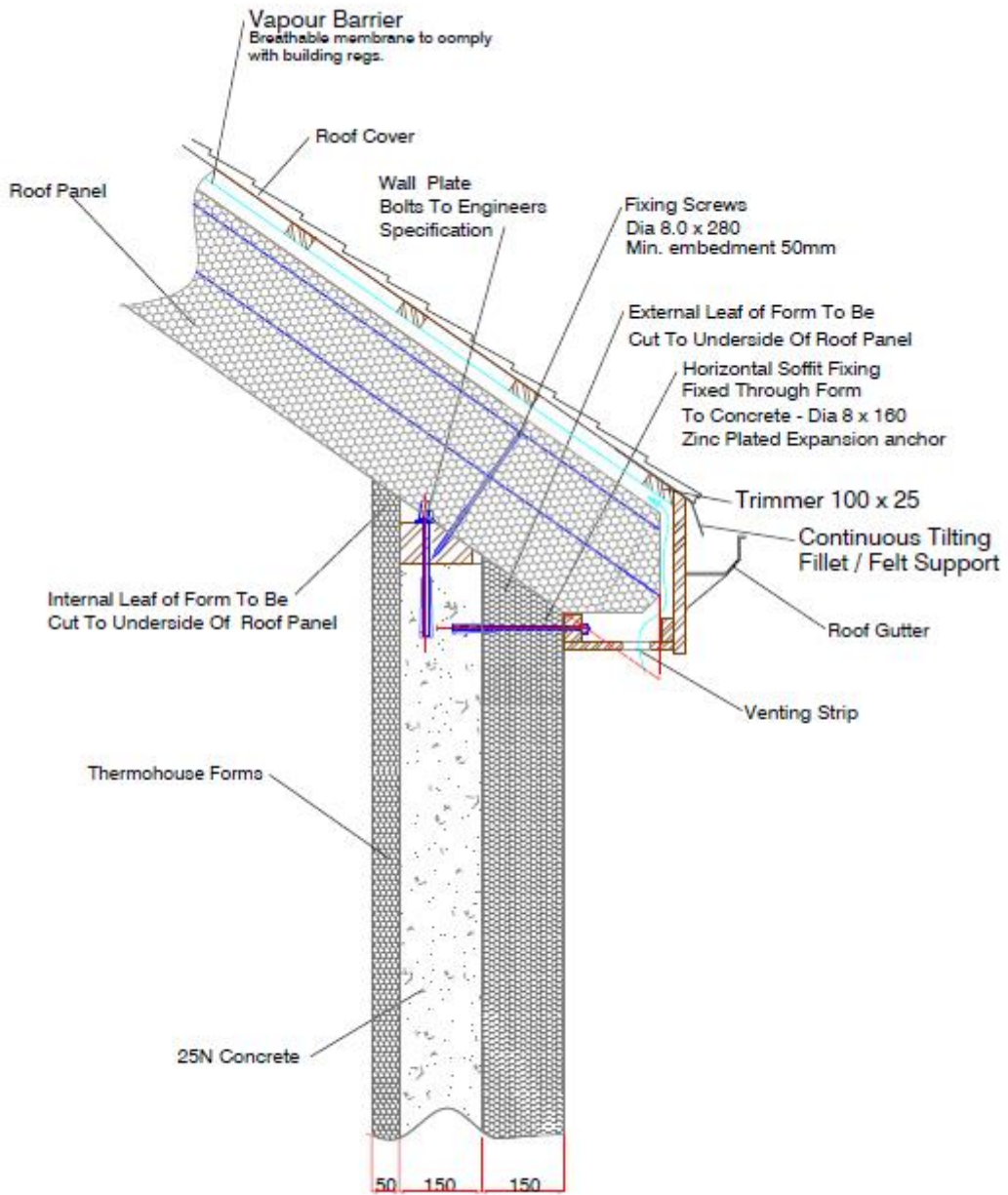

TR5 - Thermoroofto Thermowall 350 Typical Detail

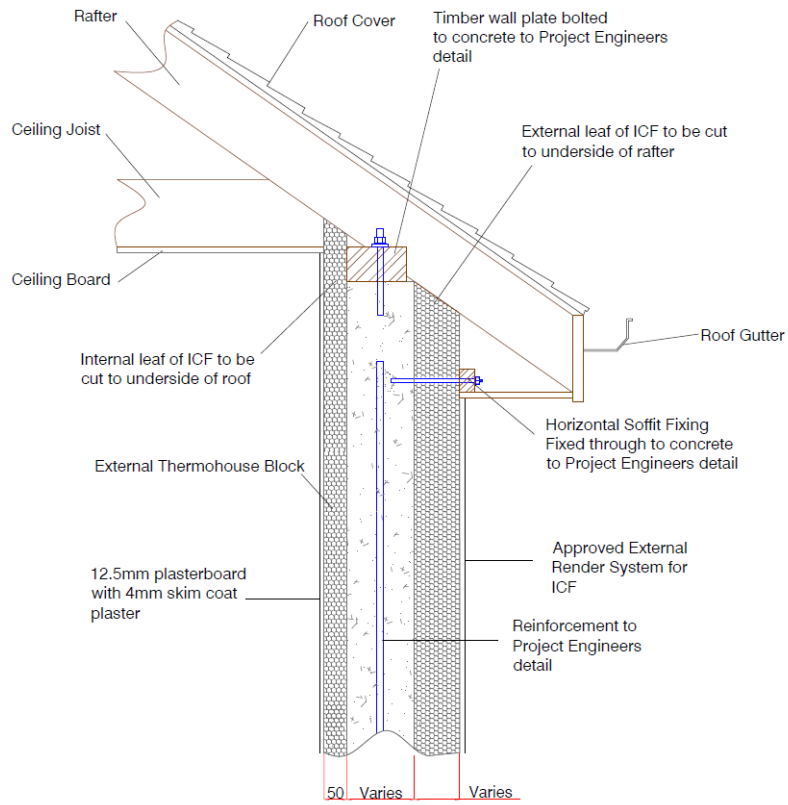

TR6 – Timber Cut or Truss Roof to Thermowall Typical Detail

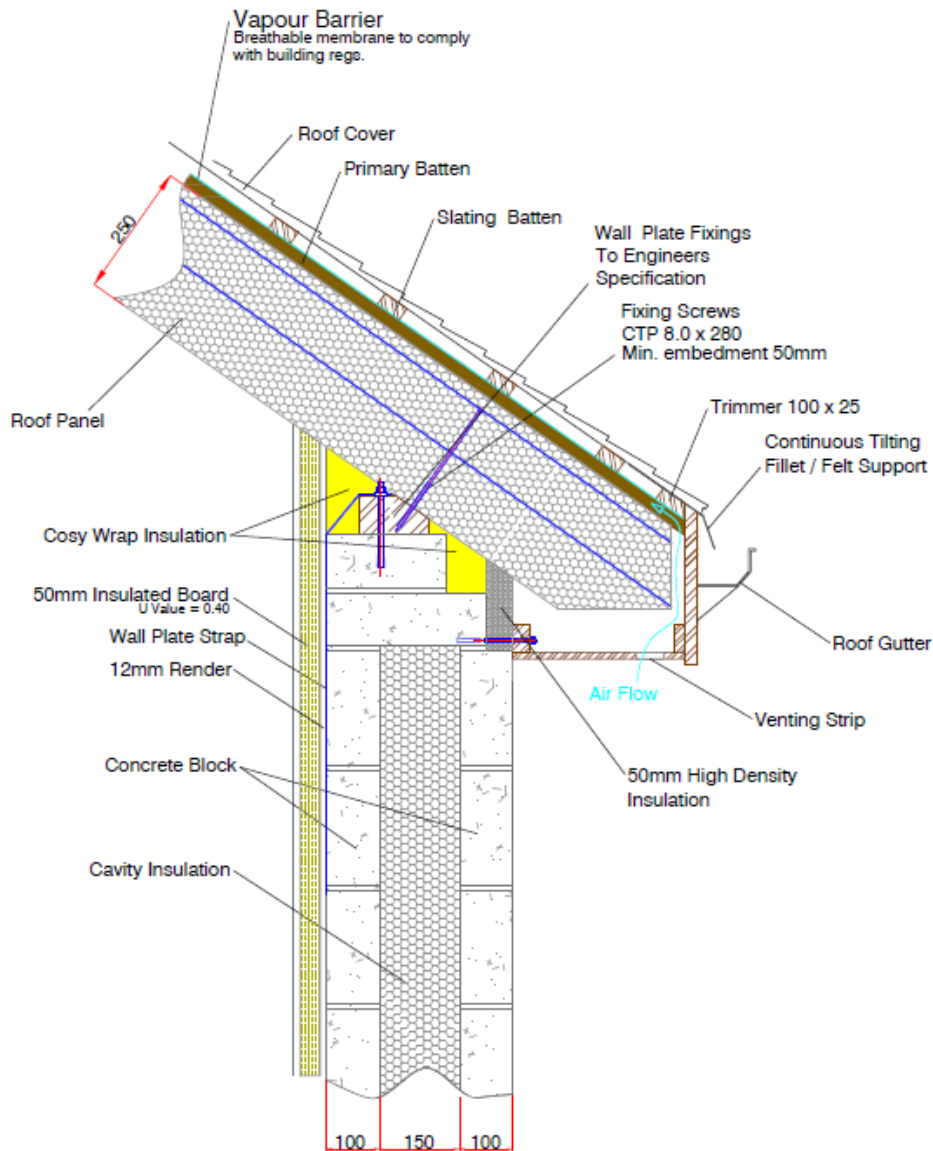

TR7 – Thermoroofto Block/Brick wall Typical Detail

Panel Fixing Screw

Once positioned correctly, each Thermohouse Roofing panel must be anchored securely at every support point to resist wind uplift. Using holding down screws through both cold formed sections within each panel, the panels are affixed to a timber wall plate, purlin, or ridge beam.

After positioning the first roofing panel and the installer confirms the alignment and levelness, the panel is secured using a diameter 8.0 x 280mm long fixing screw. These roof fixing screws must be embedded at least 50mm to ensure proper anchoring and stability.

Ridge, Hip & Valley Connections

The Thermorooft system offers remarkable versatility, empowering the design team to create roofs featuring valleys, hips, dormers, and more. Its flexibility and its capability to customize panels to specific shapes or angles provide numerous design advantages.

Ridge Straps

Ridge straps are rarely necessary but can be utilised if needed. In such cases, they should be crafted from either hot-dipped galvanized steel meeting BS 1449: Part 1 standards, or stainless steel meeting the criteria outlined in BS 1554 (specification for stainless & heat resisting steel) grades 302, 304, 315, 316, 321, or 347.

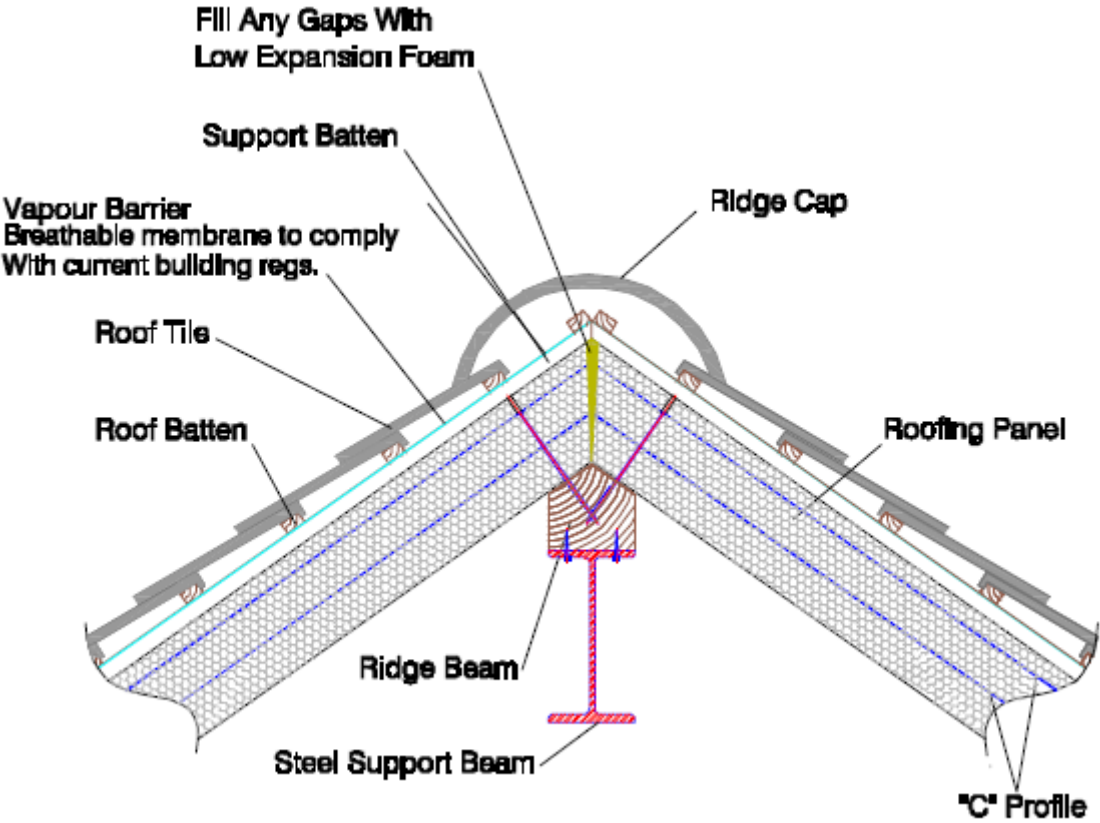

TR8 – Thermorooft on steel ridge Typical Detail

Fixing Screws
 CTP 8.0 x 280
 Install 2 no. screws
 thro' pre-drilled
 or punched "C" section
 into ridge beam
 Min. embedment 50mm

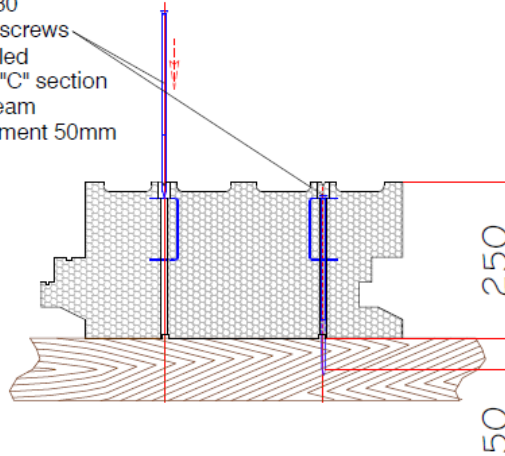

TR9 – ThermorooF Fixing Typical Detail

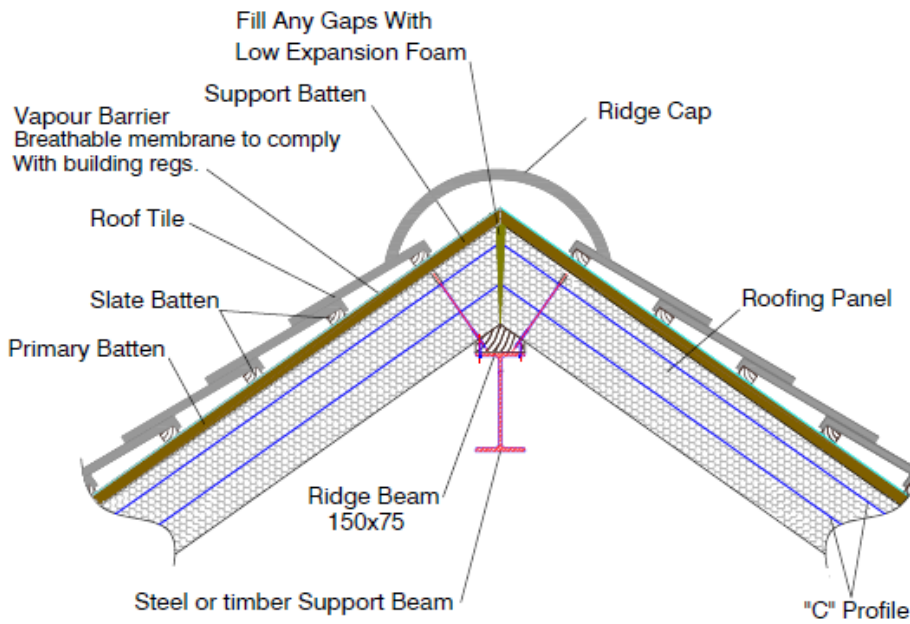

TR10 – ThermorooF on Steel & Timber Ridge Typical Detail

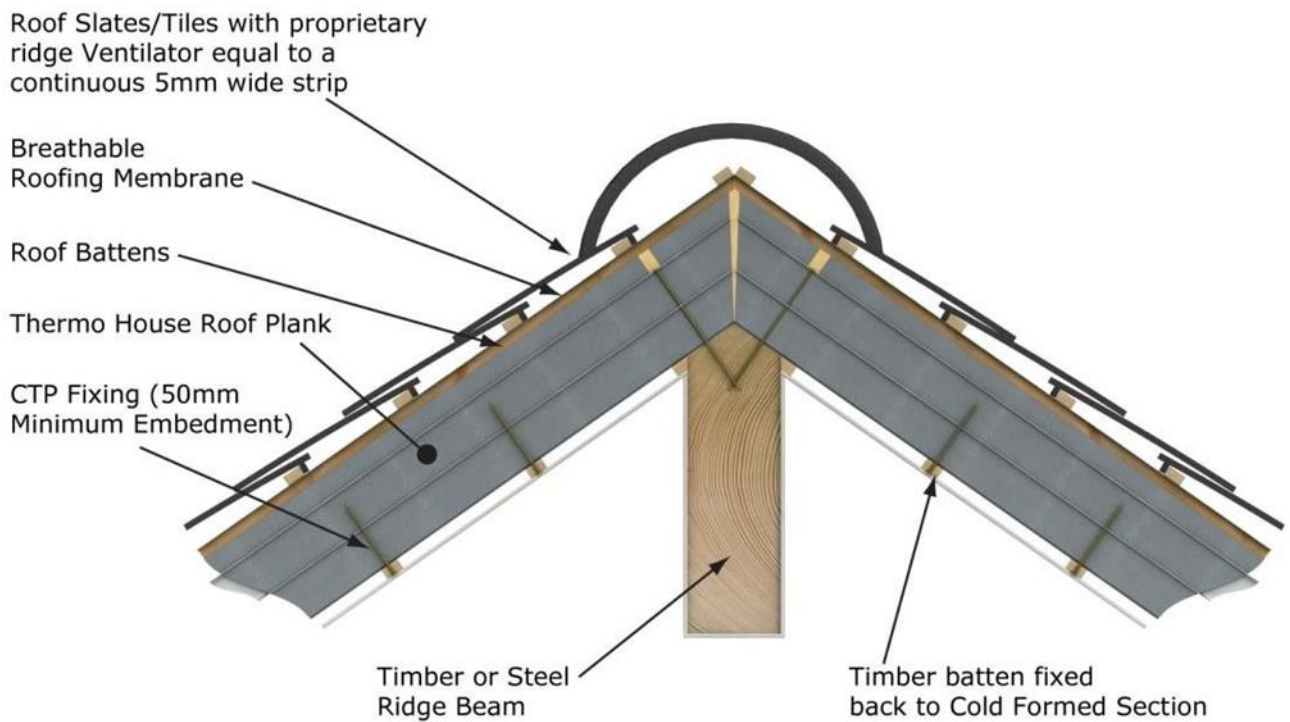

Should the engineering specifications necessitate the ridge to be an RSJ, it will need a timber capping. This capping ensures a minimum 75mm seating on the chamfered face, providing space for the Thermorooft panel to rest and allowing a 50mm embedment for the fixing screw. This setup is akin to, but mirrored in relation to, the purlin support shown in figure TR10 above. The ridge beam may also be a timber beam if engineering permits but the 75mm seating will still apply.

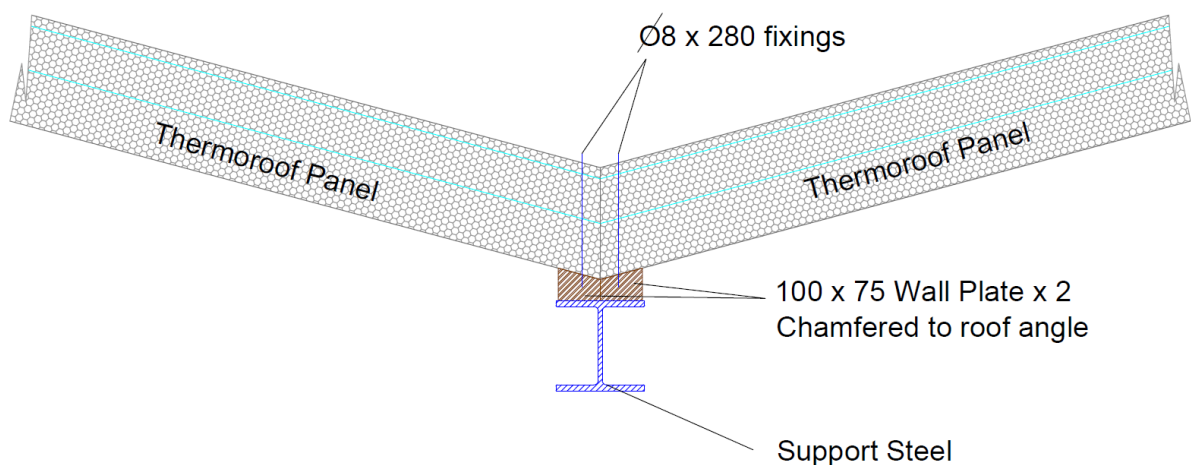

TR11 – Thermorooft Valley Typical Detail



Purlin Supports

For Thermorooft panels surpassing the maximum unsupported span (4.0m), purlin supports become necessary. These supports can take the form of steel, timber beams, or supporting walls, but their design must adhere to the specifications outlined by the Structural Engineer, ensuring compliance with all design requirements.

As a general guideline, each panel must have support every 4 meters based on the length of the roof panel along the slope angle between wall plate & ridge beam, rather than measuring the distance between walls. This calculation accounts for the panel's length along the slope and dictates the placement of necessary supports within 4.0m max. of each other.

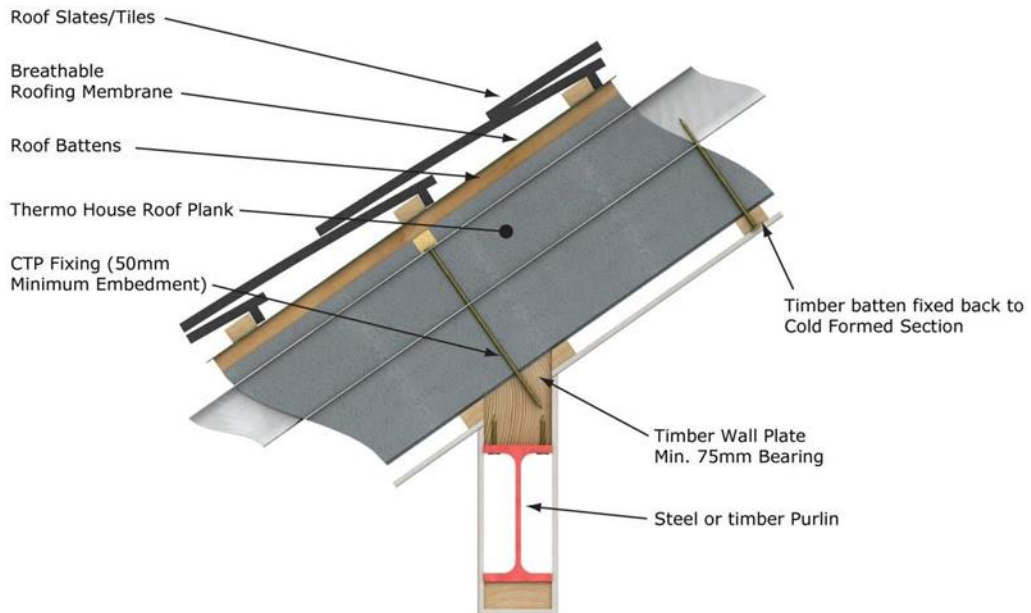
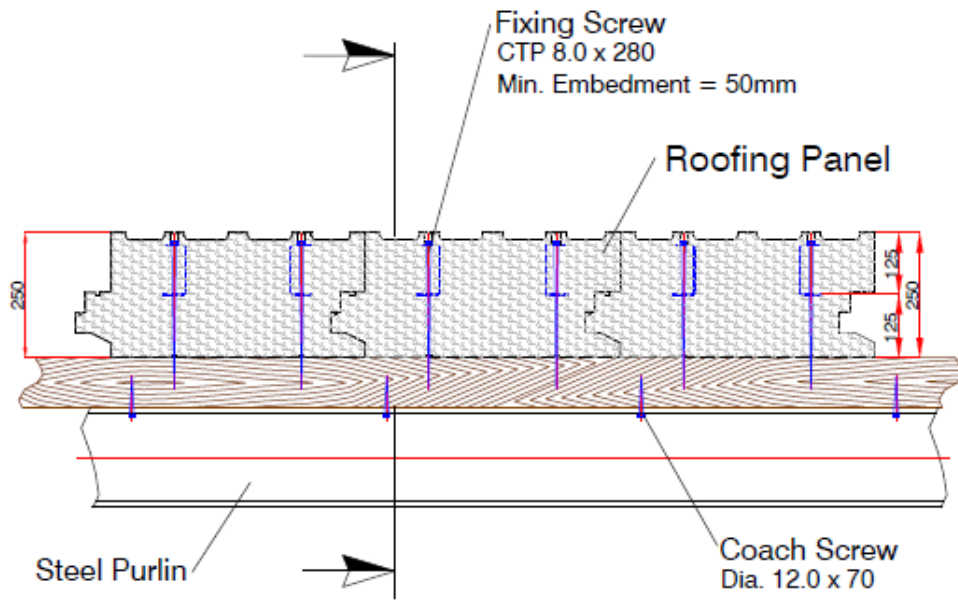

TR12 – ThermorooF Purlin Fixing Timber on Steel Typical Detail

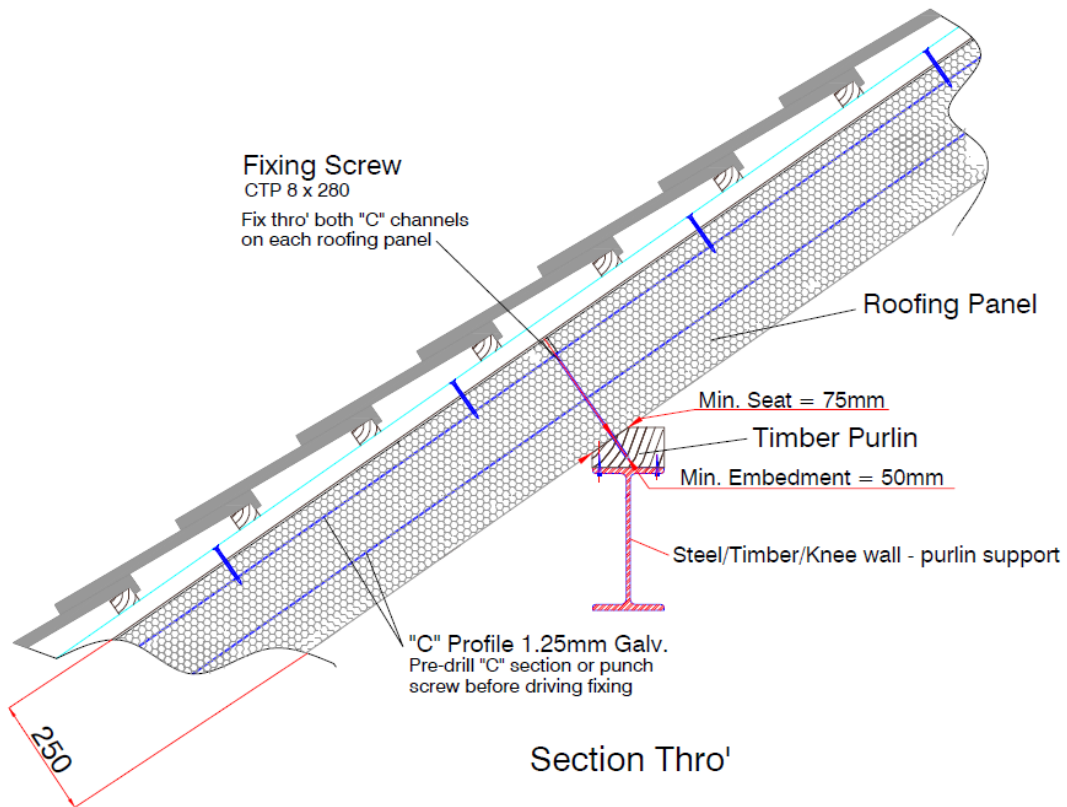

TR13 – Thermorof Purlin Fixing Timber on Steel through section Typical Detail

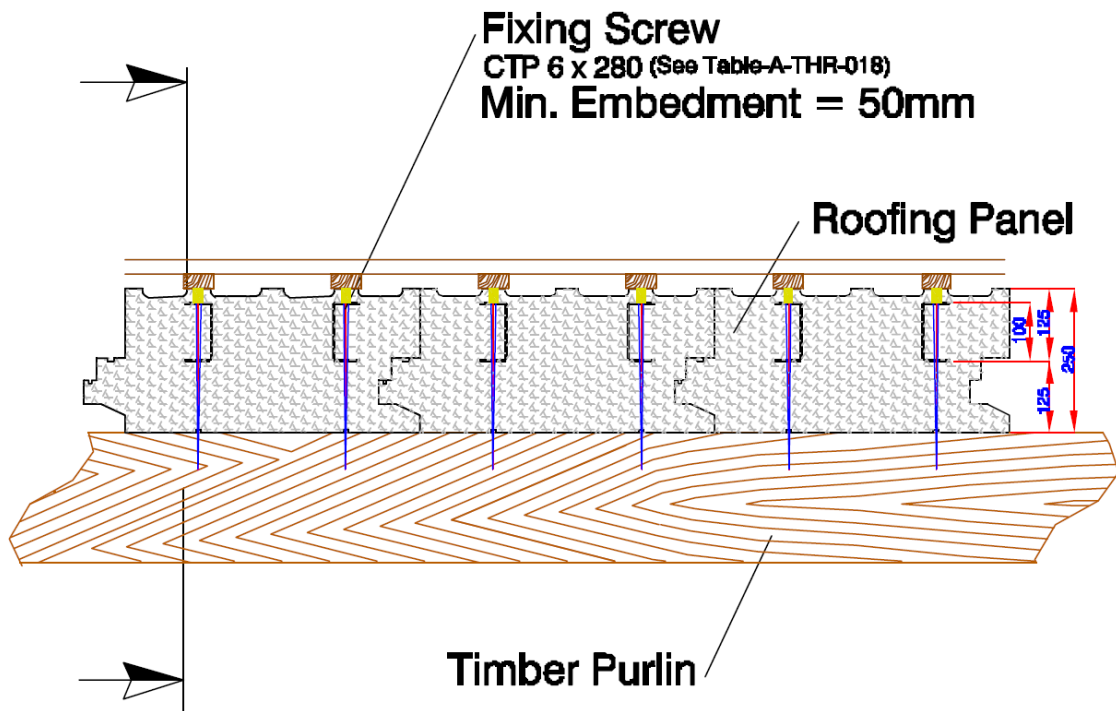

TR14 – Thermorof Timer Purlin Fixing Typical Detail

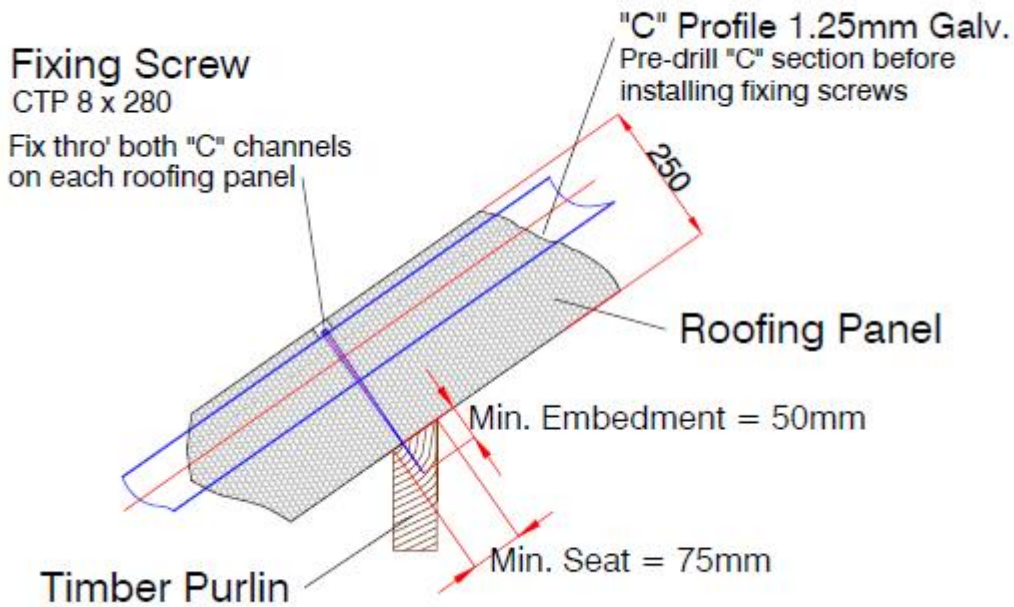

TR15 – Thermorooft Timber Purlin through Section Typical Detail

When concealing the required purlin without boxing it, the design engineer can explore the following options to assess their suitability.

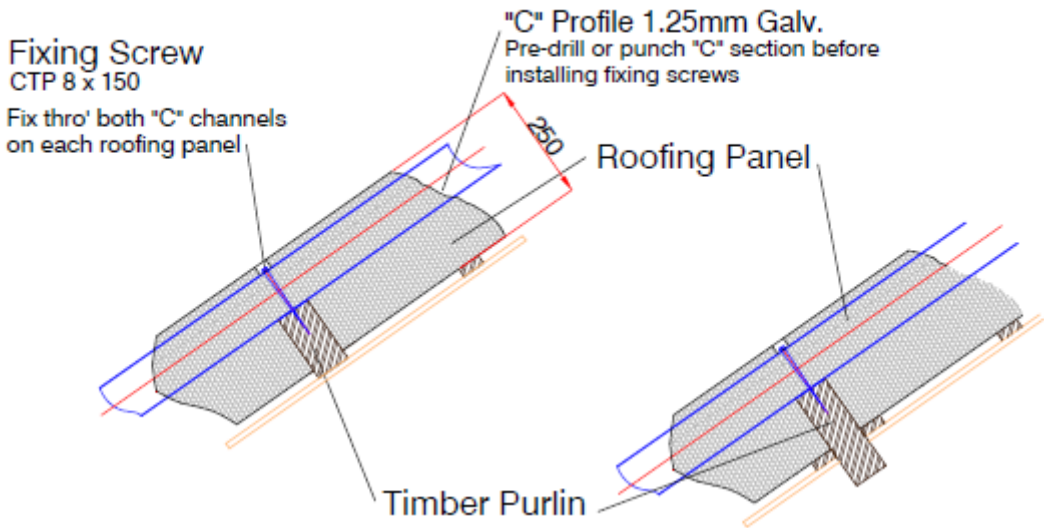

TR16 – Thermorooft Concealed Timber Purlin Typical Detail



Thermorooft Partywall

When integrating the Thermorooft panel with the Thermowall party wall block, ensuring sufficient provision for firestop is crucial. The design team has the authority to designate the materials or systems required for effective firestop measures. The provided detail outlines a typical specification. However, if alternative products are proposed or used, the design team must seek technical guidance from the product manufacturer to ensure suitability.

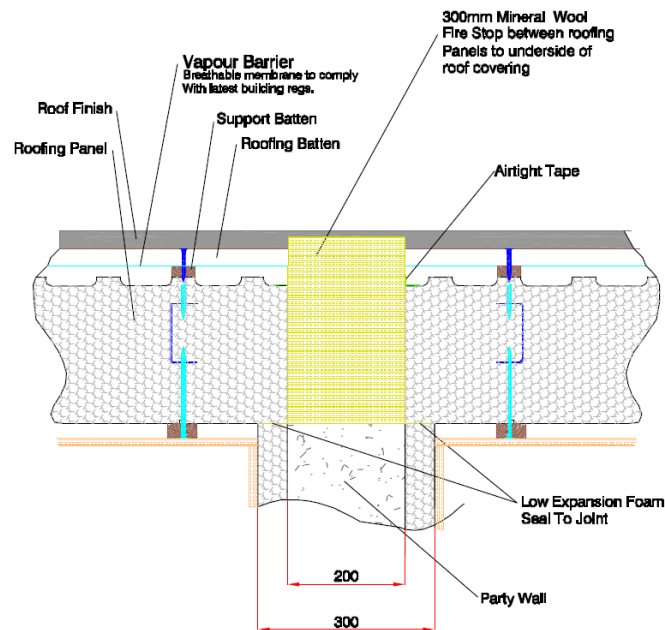

TR17 – Thermorooft & Thermowall Party wall Firestop Typical Detail

The plasterboard used as internal lining with the Thermohouse Roofing Systems must possess a spread of flame rating equal to Class 0. As per the Irish Building Regulations (specifically, Appendix A Table A1 of part B on fire safety), there's no requirement for a roof element to be fire-resistant. However, at the boundary or party wall junction between two adjacent dwellings, the dividing wall's integrity must extend upwards through the roof structure, as demonstrated in figure TR17 above and the photos below.

It's important to note that regulations in different countries may differ, and it's essential to consider these regulations when finalising all design details.



Void in Panels For Fire Batt infill

Concrete In-Fill on Party Wall

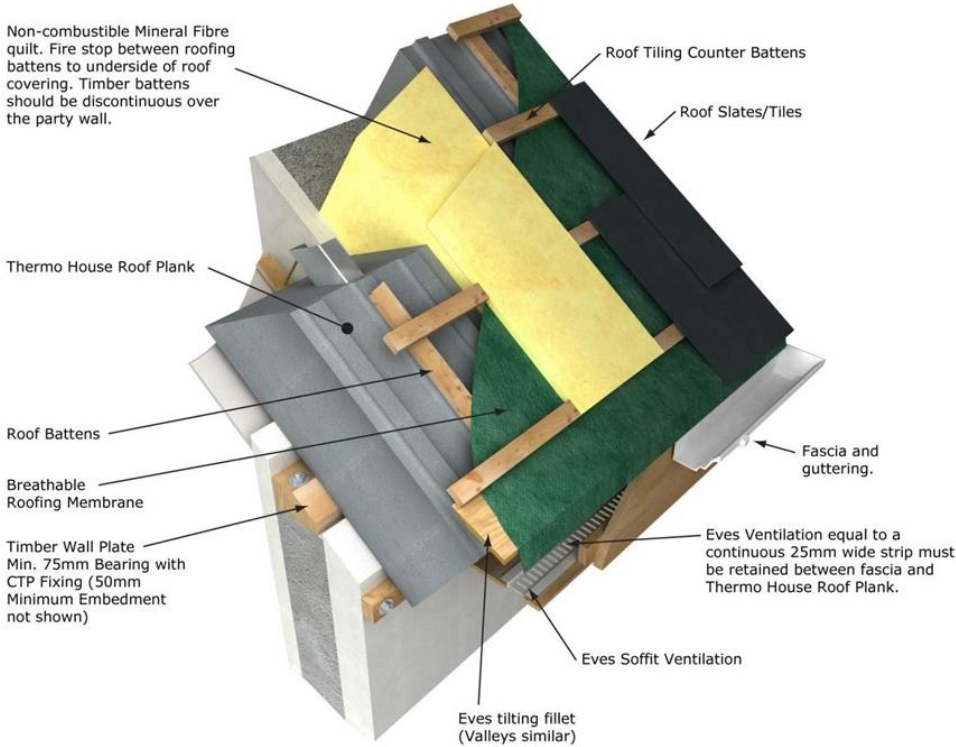

Firestopping a Party wall roof Junction

ThermorooF Air-tighness & Sealing

During installation, it is recommended to apply a complete 10-15mm diameter continuous bead of low expansion adhesive foam on the lower inner corner of the female section of the joint groove of each panel just before the next is fitted in position by pushing the tongue into place, fix the panel in position and allow glue to set while you continue with the next panel. Additionally, any gaps or damage caused during installation, like voids at the gable wall /ridge or drill holes for holding down screws, should be sealed using expanding foam.

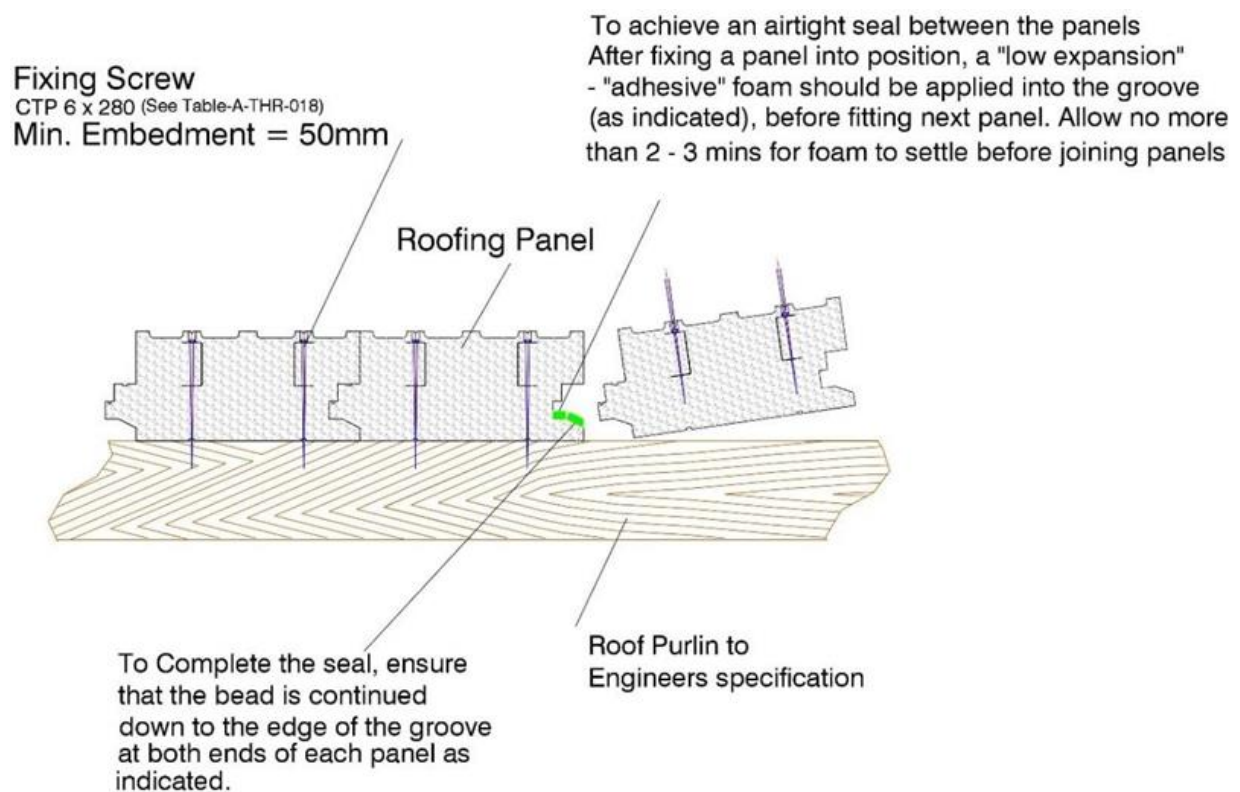

TR18 - ThermorooF Airtightness sealing Typical Detail

Thermohouse build with a Multi faceted Thermorooft construction



□



Roof Windows

Roof windows can be integrated into the Thermohouse roofing system, but designers must furnish details of their chosen roof window to the certificate holder. In cases of very large openings in the roof panels, the structural engineer might need to design supplementary structural steel support.

The roof panels can be cut out in a suitable location and framed out as detailed below. An alternative option with the framing is to remove the "C" section from the cut-out and fix it across the ends of the remaining "C" sections as shown here.

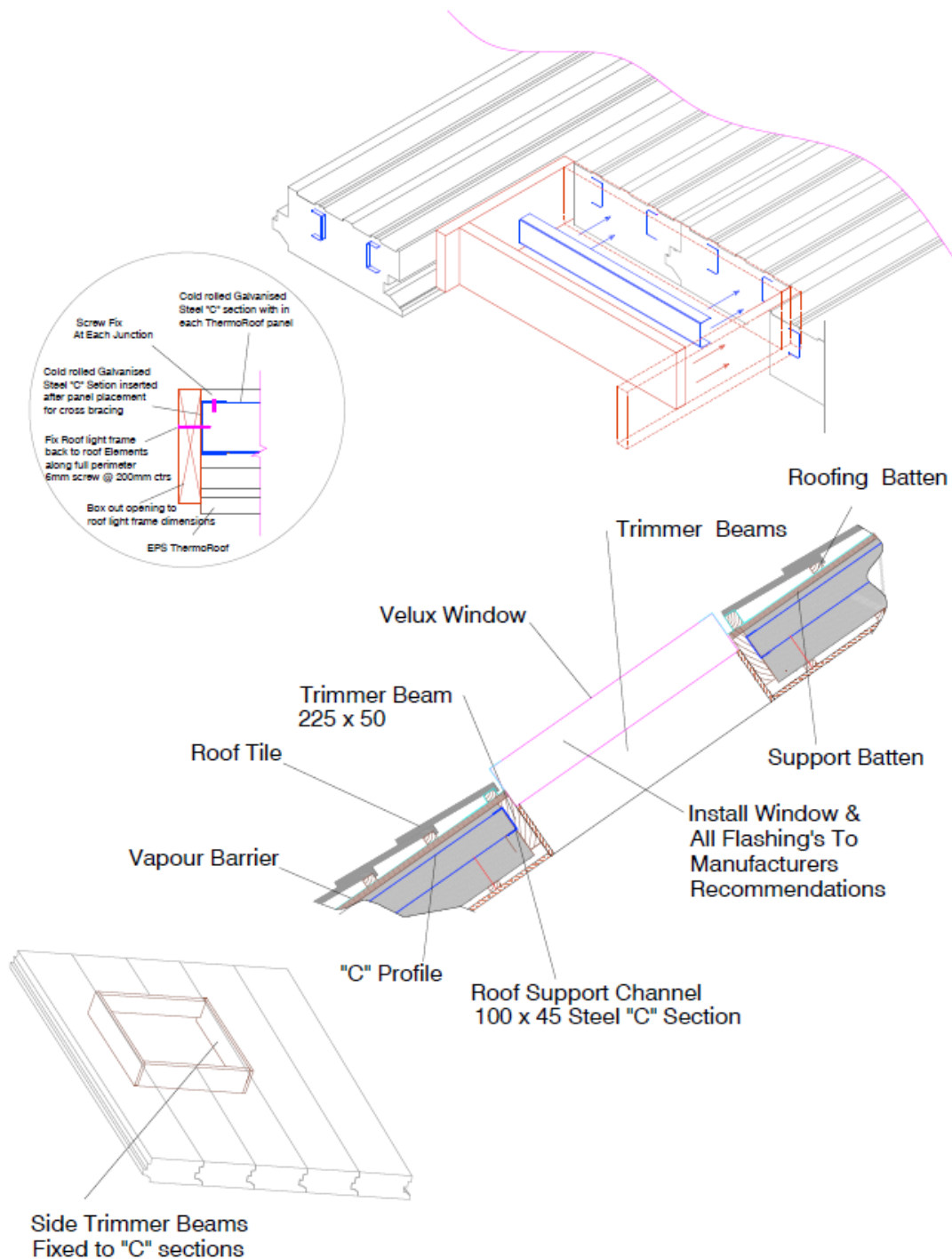

TR20 – Thermorooft Velux style rooflight Typical Detail



Typical window framing in ThermoRoof Panels

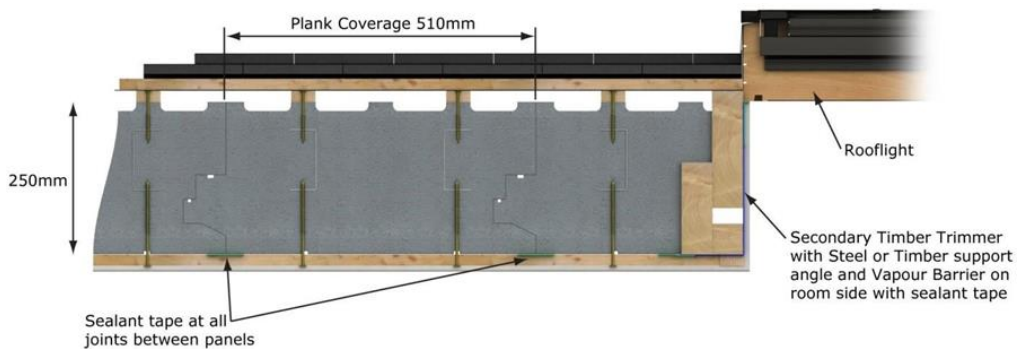
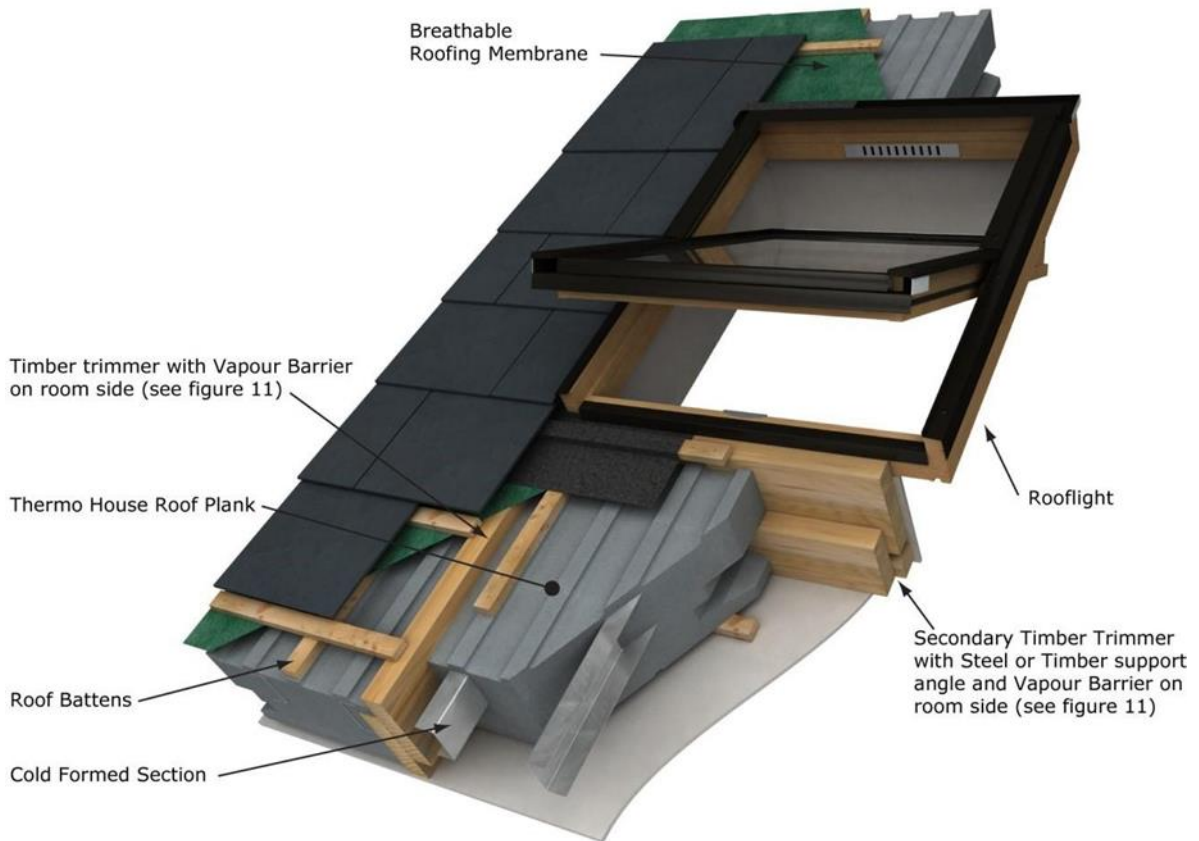

The Flexibility of Thermorooft



Multi Faceted roof with large overhangs



Curved Barn Style Roof



Multi Faceted roof with large overhangs



Curved Barn Style Roof

Dormer roofs can be integrated into the overall roof design. This can be achieved through framing constructed either with timber or steel, following the recommended method by the structural designer. After finalizing the framing, the Thermorooft panel installation can be adjusted accordingly. Below is a typical detail that can serve as a reference

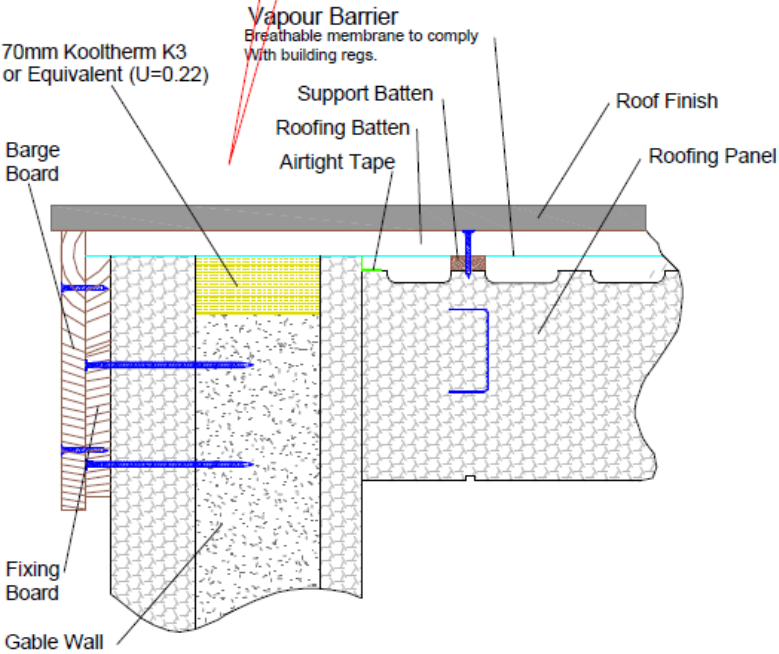
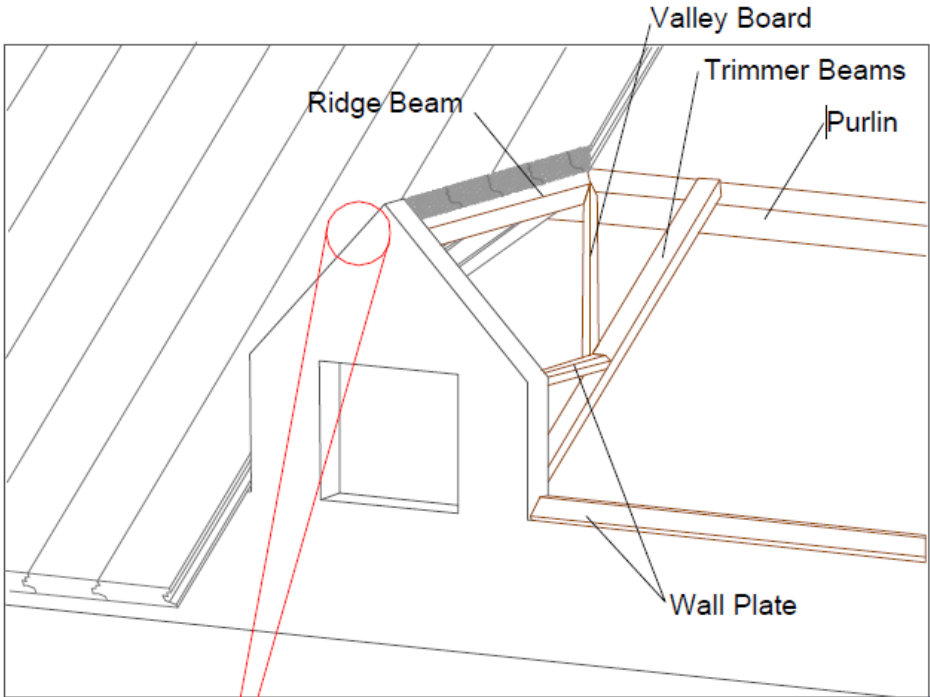

TR21 –Dormer Window Typical Detail

Battens & Vapour Membrane

Now, it's time to fit the roofing panels with primary timber battens. These primary battens should be installed parallel to and on top of each cold-formed section enclosed within the moulded EPS panels at approx. 250mm centres. This alignment ensures an even distribution of roof and wind loads across the load-bearing cold-formed "C" sections.

The initial layer of timber battens is affixed to the top flange of the cold-formed "C" section (marked on the panel with a "V" groove on the up-stand) using self-tapping Ruspert corrosion-resistant fixings or a similar alternative. For further details on all fixings used, please refer to table 9 in our IAB certificate.

Next, a suitable vapor-permeable underlay is draped over the primary timber battens. This underlay is then counter-battened to accommodate roof tiles or slates or whatever is the finish of choice. The roof tiles or slates etc, can be securely fixed onto the counter battens. For additional guidance, please see Diagrams below.

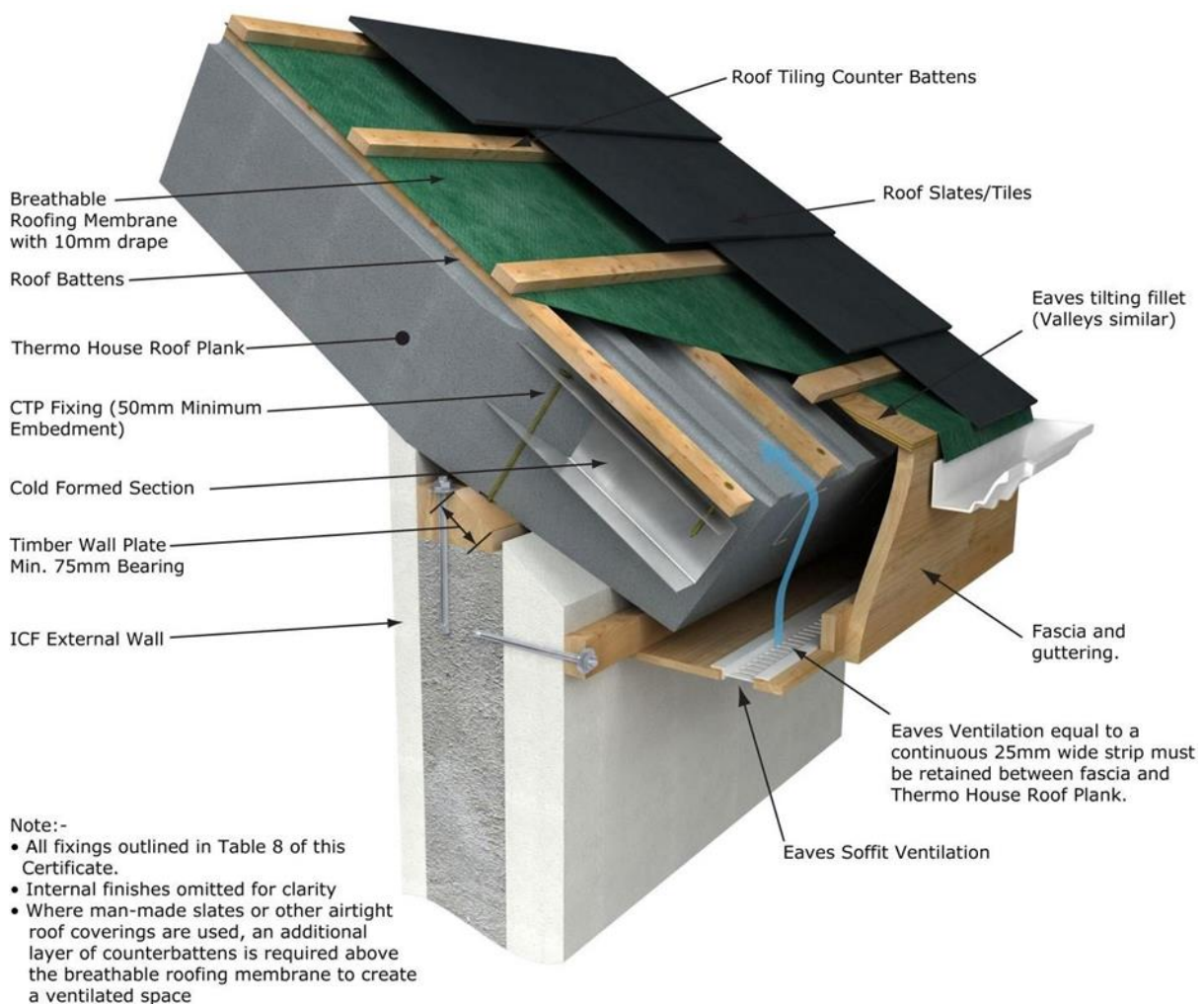

**Only Suitable Self Tapping "wing Drill Tek Screws"
To Be Used To Fix The Battens
(See Table-B-THR-018)**

*Calculation For Proper Screw Length;
For A Standard Roofing Sheet @ 250mm With A 30mm Support Lath
Screw Length = 25+30+30 = 85mm*

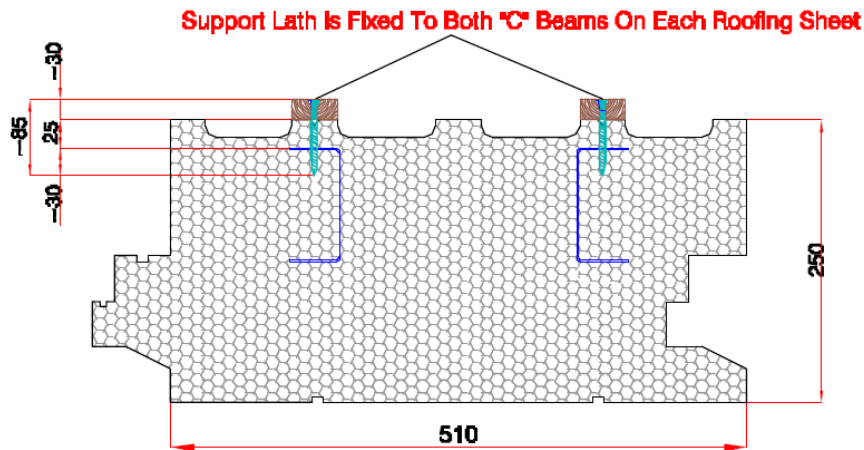

TR22 – Roof Batten Fixing Typical Detail

Underlay, Slating & Tiling

The Thermohouse Roofing System necessitates the use of a breathable roof underlay. Follow the installation guidelines provided in Detail TR23 below for proper underlay placement. This underlay is supported between the primary roof support battens and the battens used for roof tiling.

For adequate roof ventilation, comply with relevant building regulations and adhere to the recommendations outlined in BS 5250, the Code of Practice for Control of Condensation in Buildings.

When utilizing man-made slates or airtight roof coverings, an additional layer of counter battens is essential above the breathable roofing membrane. This setup creates a ventilated space. To ensure adequate ventilation in this unobstructed free air space between the roof tile and the breathable roofing membrane, eave vent tiles can be installed if necessary.

Finally, when it comes to slating or tiling, adhere to the appropriate regulations and ensure workmanship aligns with BS 8000-6, the Code of Practice for Slating, Tiling, Roofs, and Claddings.

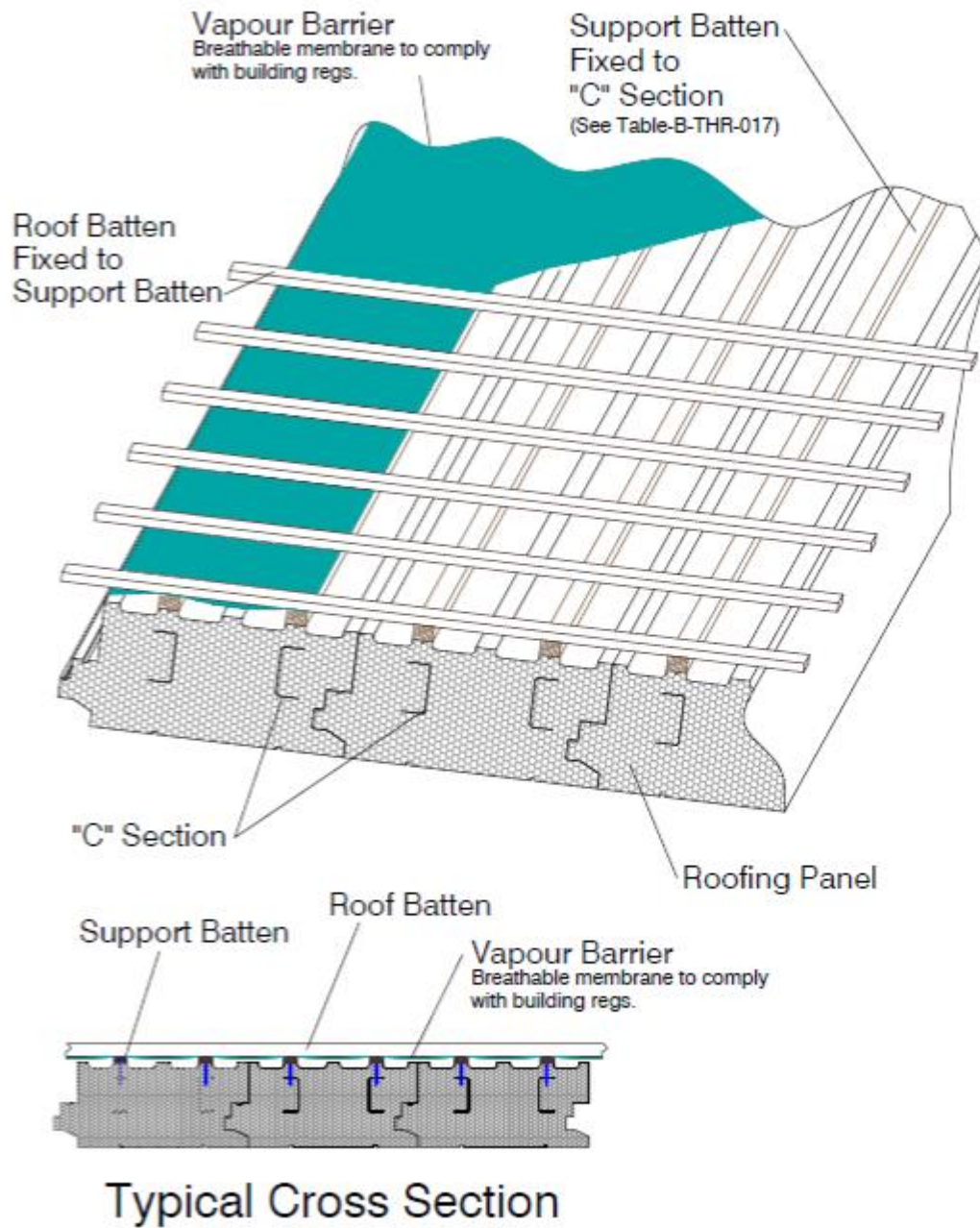

TR23 – Roof Batten & Underlay Fixing Typical Detail

Chimney

Chimneys fall outside the scope of the Thermohouse Roofing System and are not covered by our certification. However, the system can accommodate an approved pre-fabricated chimney system or a traditional masonry chimney.

Compliance with Part J of the Irish Building Regulations regarding heat-producing appliances necessitates certain separation distances for combustible materials, such as polystyrene insulation. These requirements stipulate:

- a) A separation distance of 200mm from a flue, or
- b) A separation distance of 40mm from the outer surface of a brick or block-work chimney or fireplace recess.

All penetrations, such as chimney flues, must be appropriately addressed by adding extra purlins or primary structural support members. Please refer to Below Diagrams for further guidance.

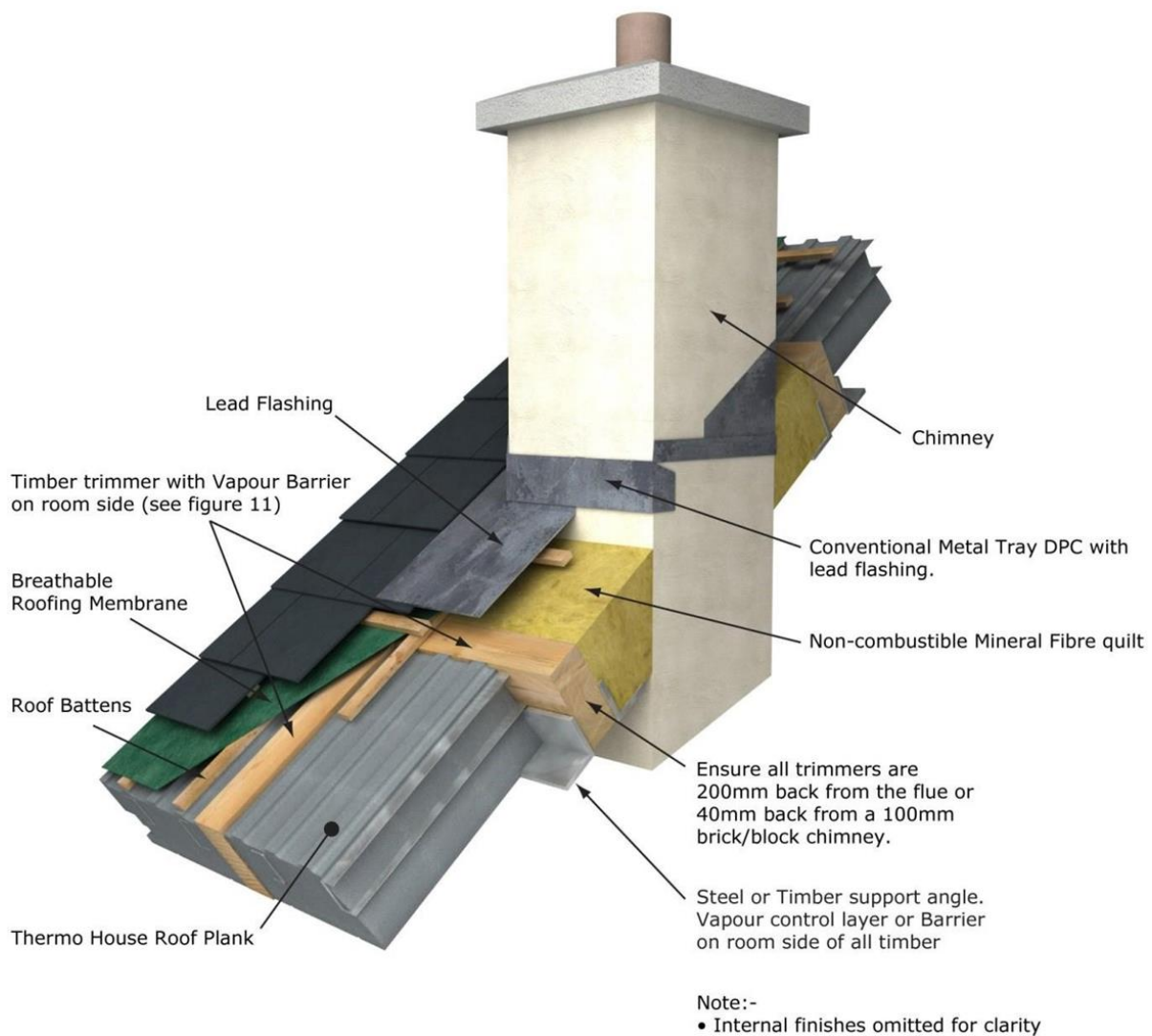

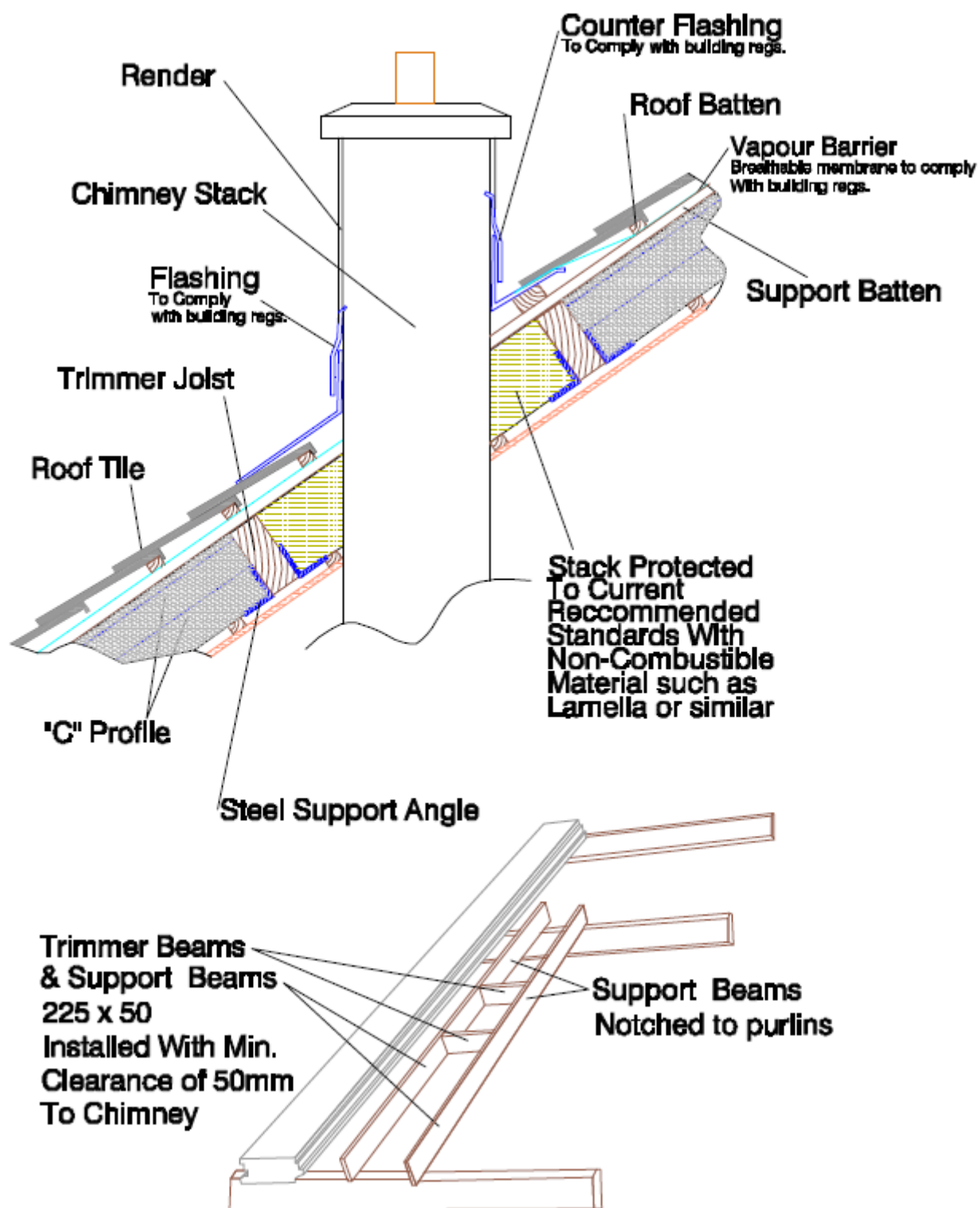

TR24 – Chimney Stack Cross Section Typical Detail

Facia & Soffit / Eaves Detailing

The eaves section, where the Thermorooft panel meets the external wall, necessitates finishing with Facia & Soffit panels. Several methods can achieve this, ensuring secure fixing points for supporting battens. Facia & Soffit options include timber, plywood, or UPVC materials, with the finishes and product specifications determined by the architect's design. Additionally, it's worth noting that this area typically serves as a fixing point for guttering installation. Below, you'll find various samples of photos, diagrams, and images illustrating different options for consideration.

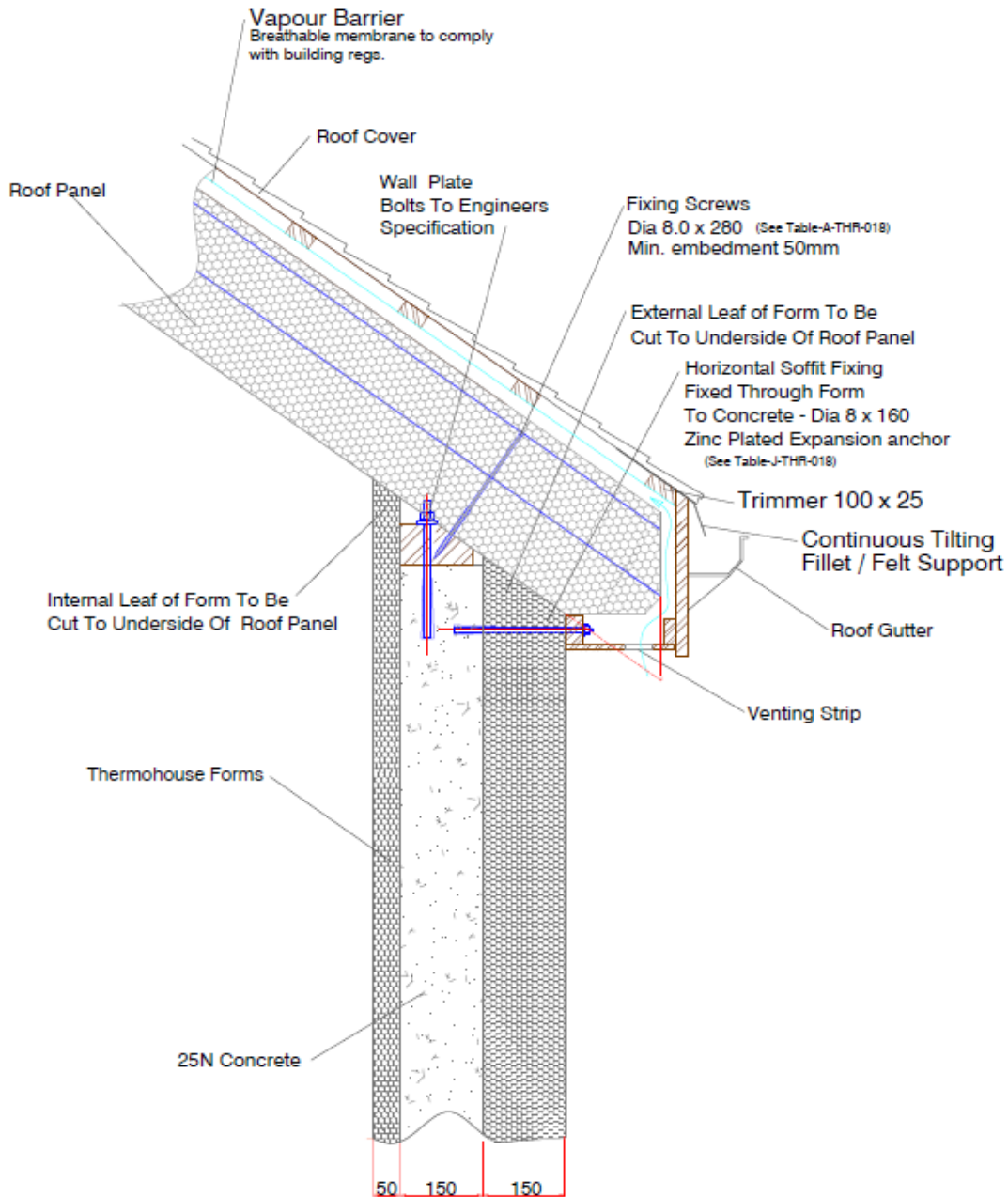

TR25 – Angled End Thermorooft Section Typical Detail

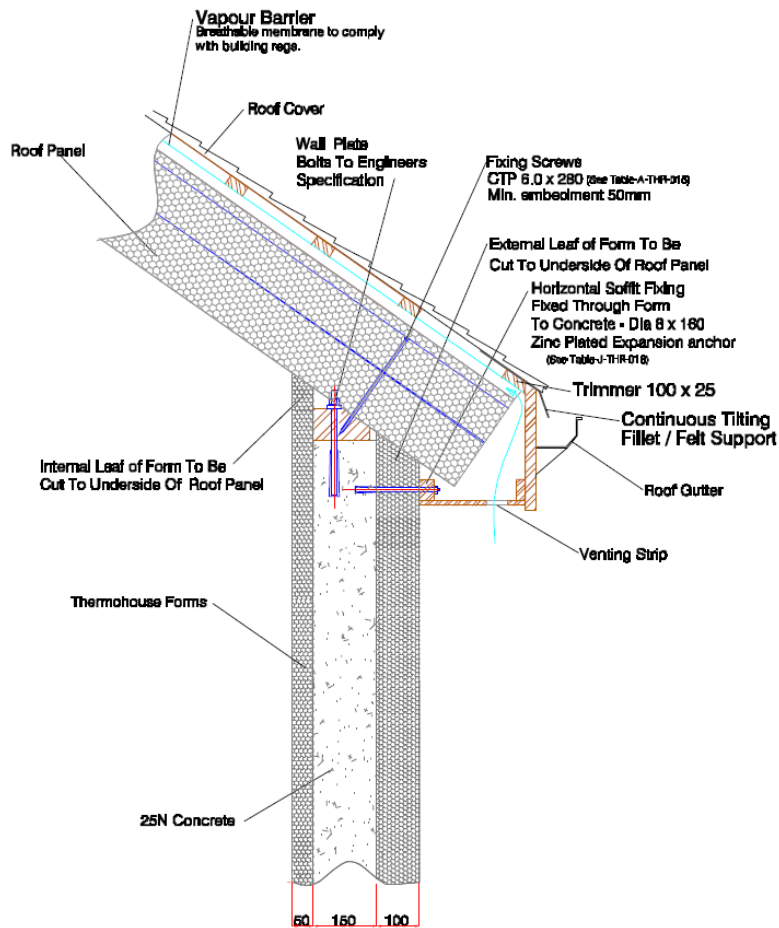

TR26 – Straight End Thermorooft Section Typical Detail

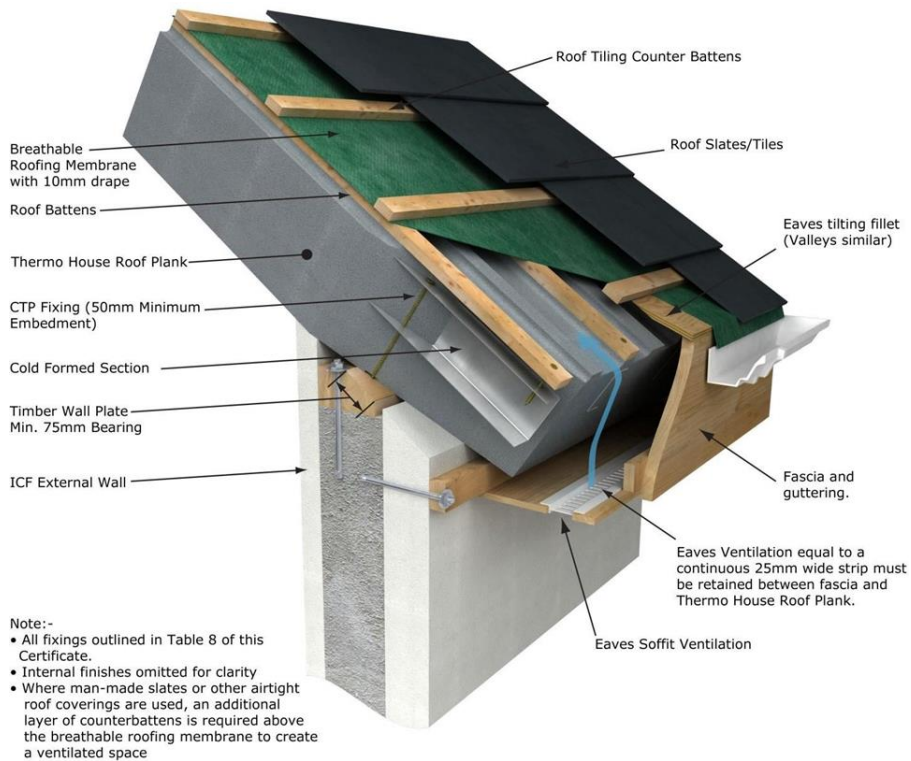

Thermorooft Eaves Section on Thermowall Typical Detail

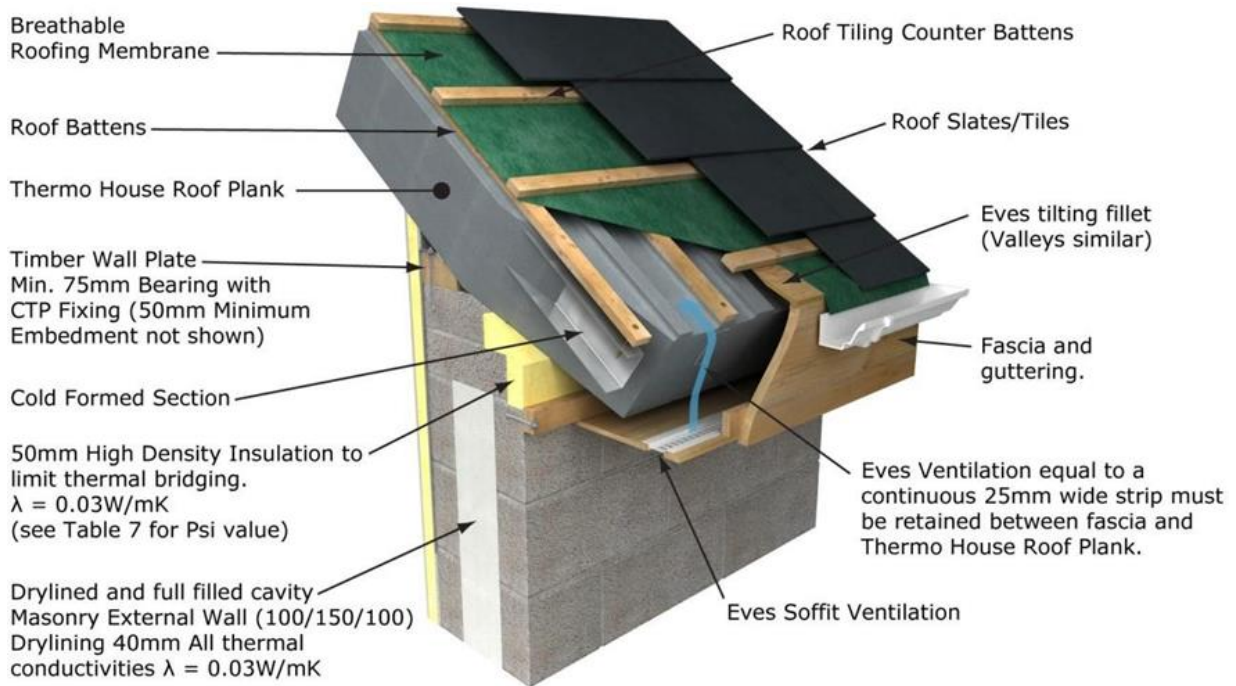

Thermorof Eaves Section on Traditional Wall Typical Detail



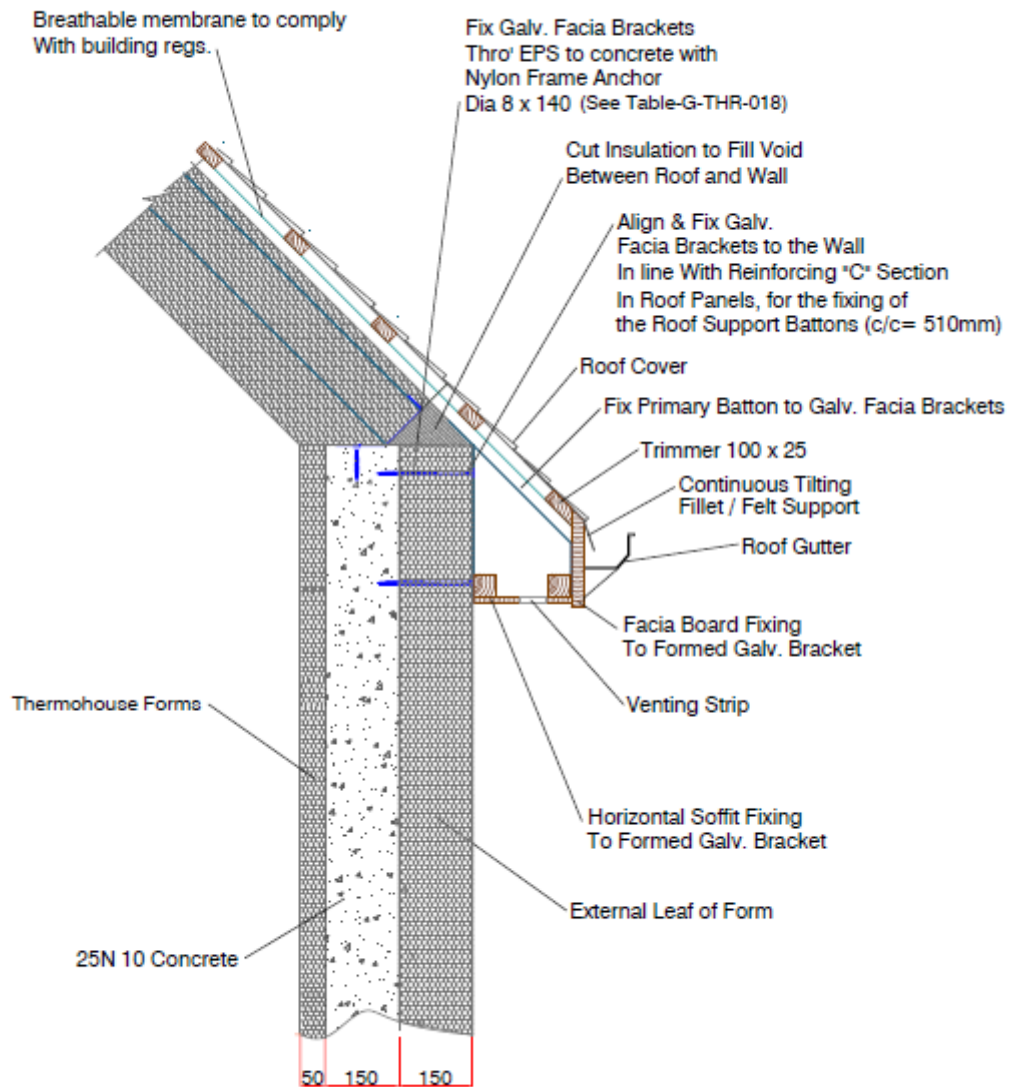

TR27 – Galvanised Wallplate Shoe overhang Section Typical Detail

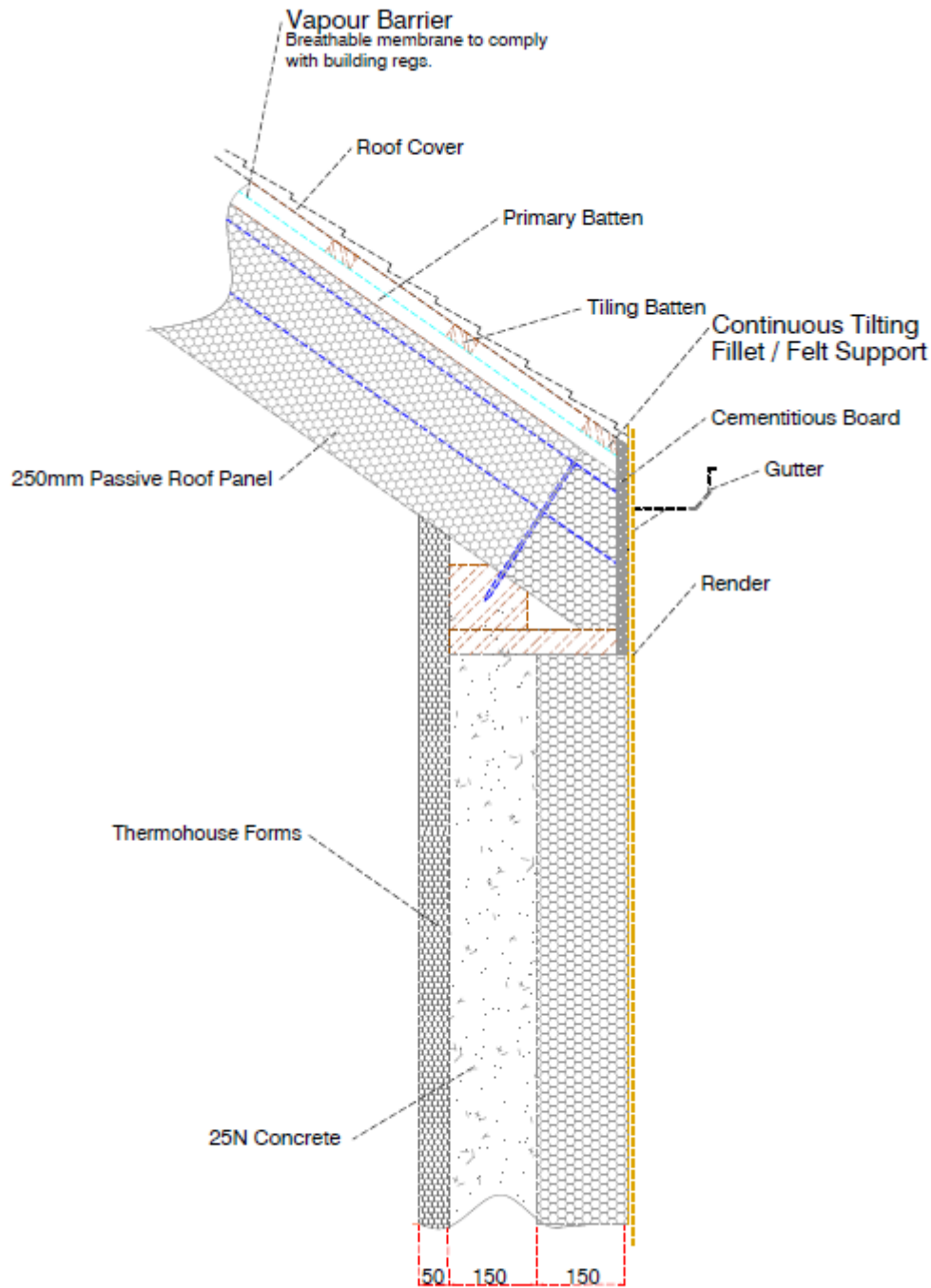

TR28 – Flush Facia Section Typical Detail



Facia & soffit Detail



Breathable membrane & Slating/Tiling Batton

Gable Ends

The finishing of Gable ends can vary, contingent upon the specific design preferences of the Architect and the overall project needs. For each scenario, the Architect should provide detailed considerations to ensure seamless integration with the rest of the structure.

Displayed below are several images showcasing different options employed in past projects.



TR29a - Option A - Timber Ladder Gable End

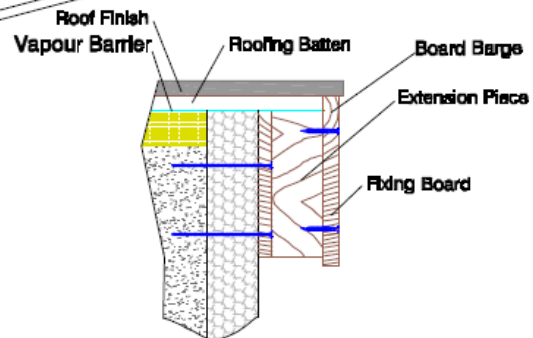
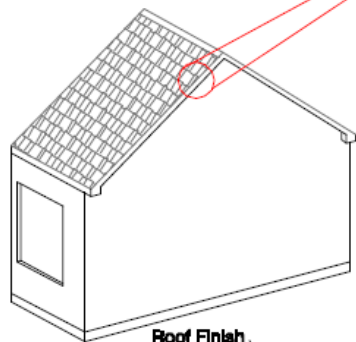
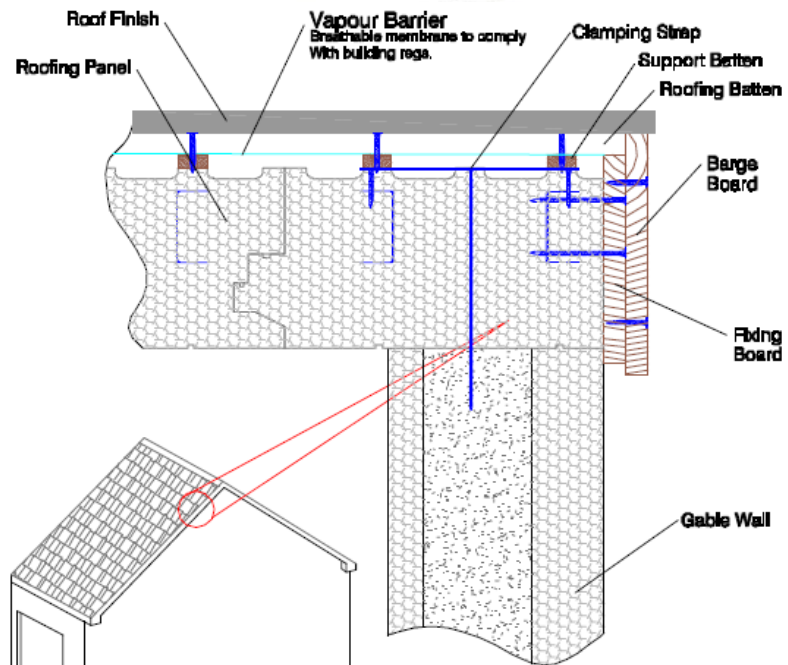
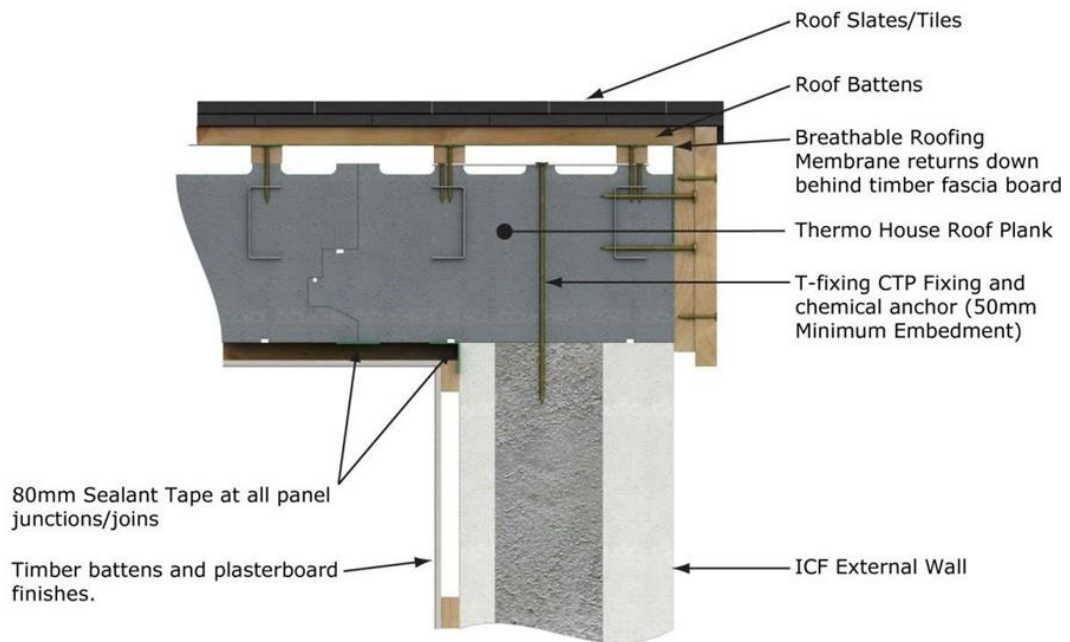

Optional - Barge Extension Ladder

TR29b – (Option B) – Thermorooft Panel over Wall

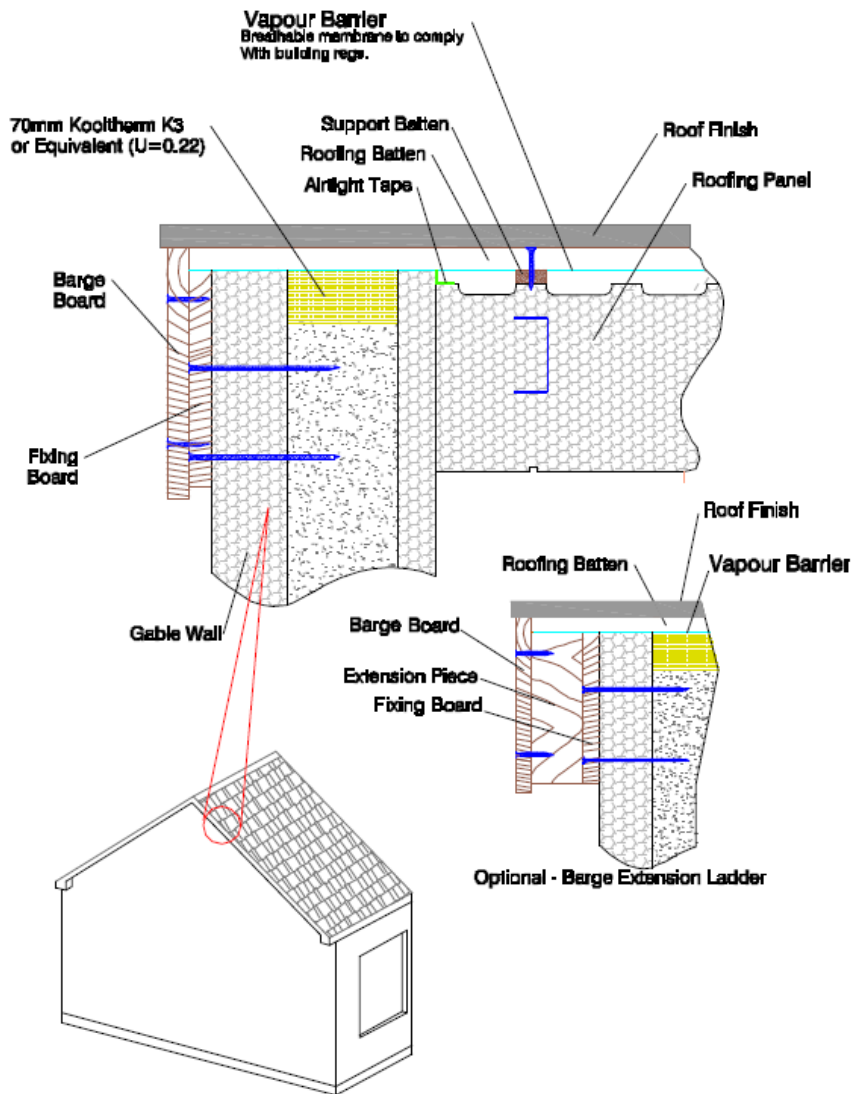
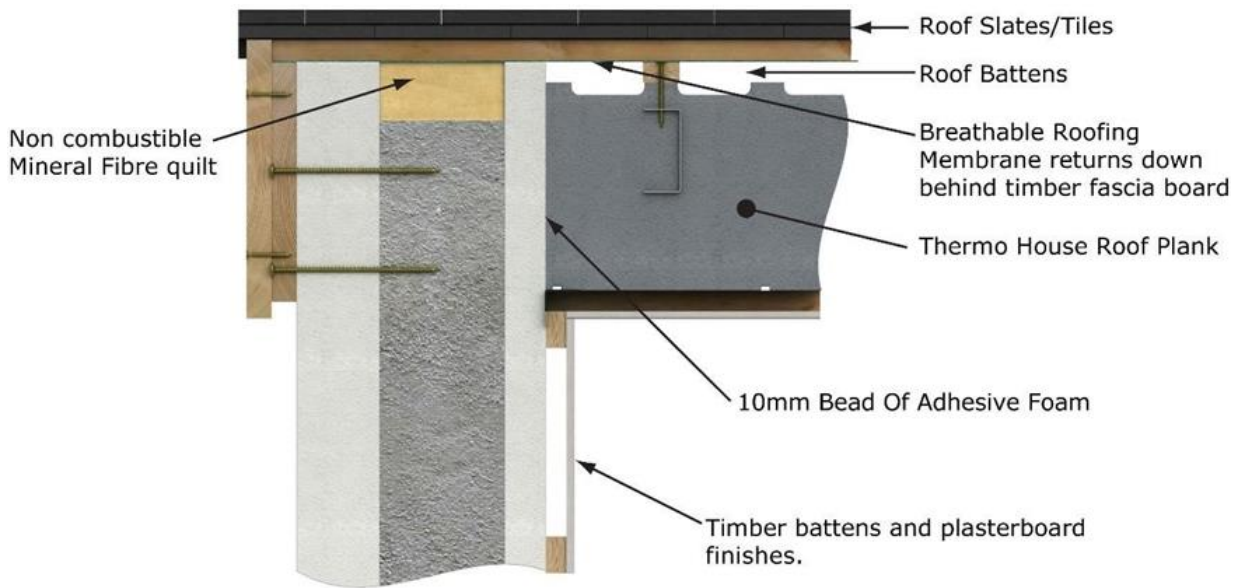

TR29c - (Option C) – Thermorof Panel Abutment to Wall

Collar Ladder Bracing

Collar ladders serve to triangulate the roof when a flat ceiling line is desired, particularly in situations where there are no loadbearing walls to support the ridge beam. In such cases, the ridge is temporarily propped during the installation and fixation of the Thermorof panels.

Following the completion of this process, collar ladders can be prefabricated in sections. They are then positioned beneath the roofing panels and securely fixed through to the reinforcing "C" sections molded into the Thermorof panels. Once the collars are in place, a prop/hanger may be installed from the double collar location on the collar ladder to the ridge beam if deemed necessary. All designs must be executed under the supervision of the Structural Engineer.



Pre-Fabricated Collar Ladder Positioned before panel placement



In-Situ Collar Ladder

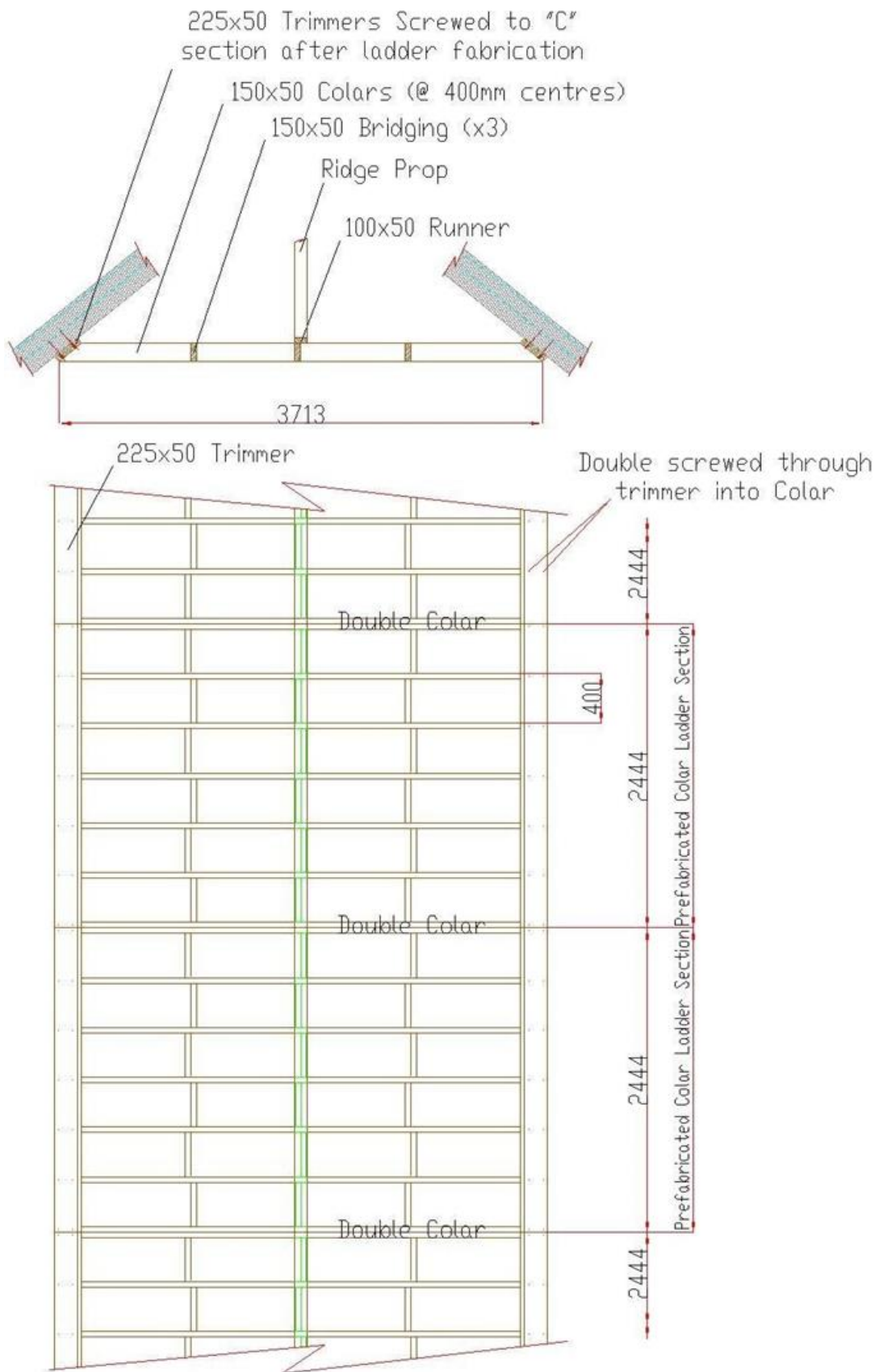

TR31 – Fabrication of Collar Ladder

Roof Finishes

External Finishes

After securely fastening the panels to wall plates, purlins, and ridge beams, the Thermohouse Roofing System is ready for the installation of the primary battens, membranes, and counter battens. These components are suitable for use in conjunction with traditional concrete tile or slate constructions, or any other desired roof finish.





Lead Flashing

When incorporating Lead flashing details, adhere to the specifications provided by the architect. Use the following detail as a reference, which should be adjusted by the architect as necessary.

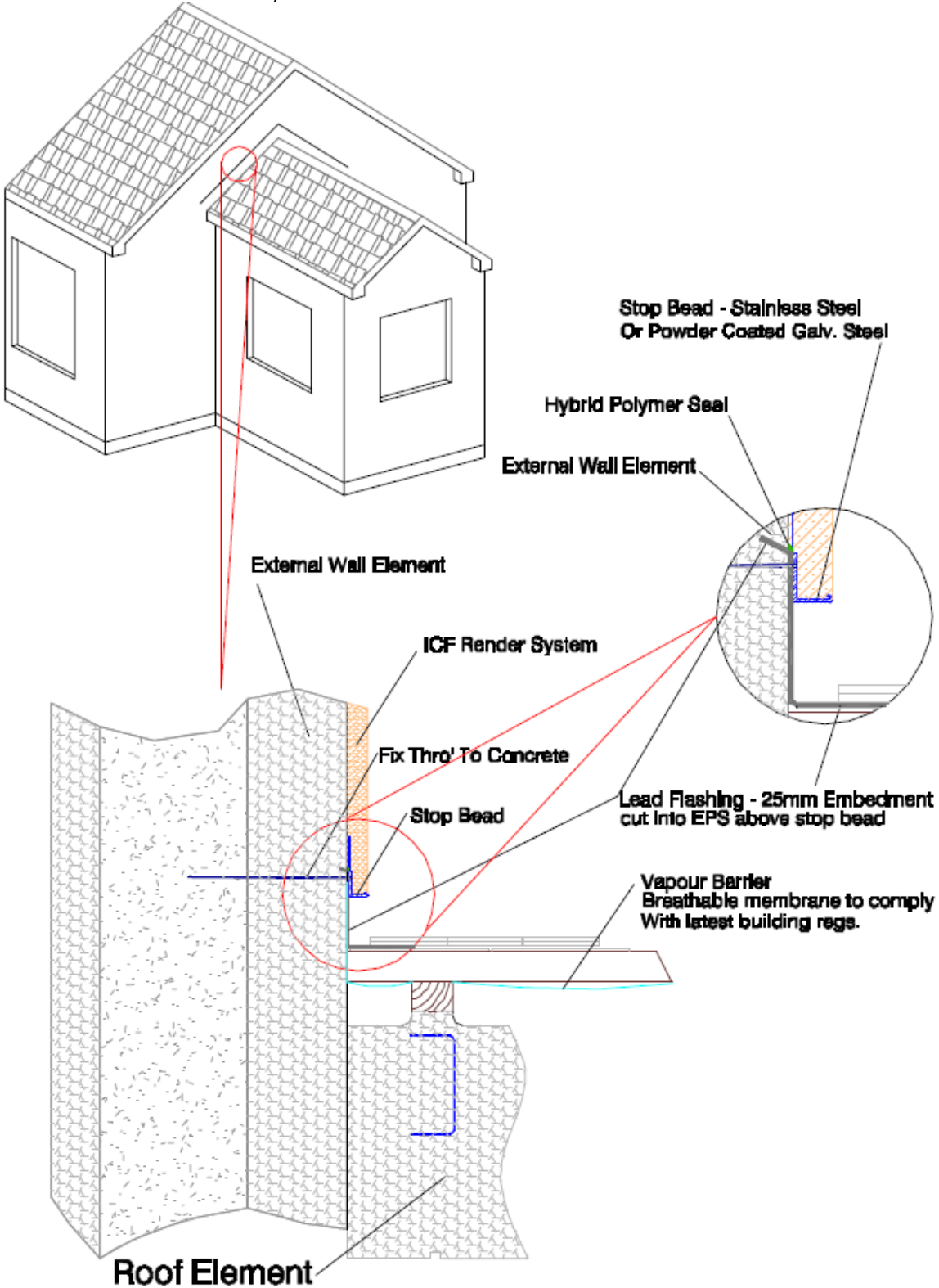

TR32 – Lead Flashing Typical Detail

Internal Finishes

The internal roof finishes present several options:

- Timber battens are affixed to the bottom flange of the cold-formed section using self-tapping Ruspert corrosion-resistant fixings approx. 85mm long.

The below photo's and sectional details will demonstrate various fixing methods for these internal finishes. Additionally, architects might recommend alternative systems. However, any systems used based on architect specifications must comply with the manufacturer's installation guidelines.

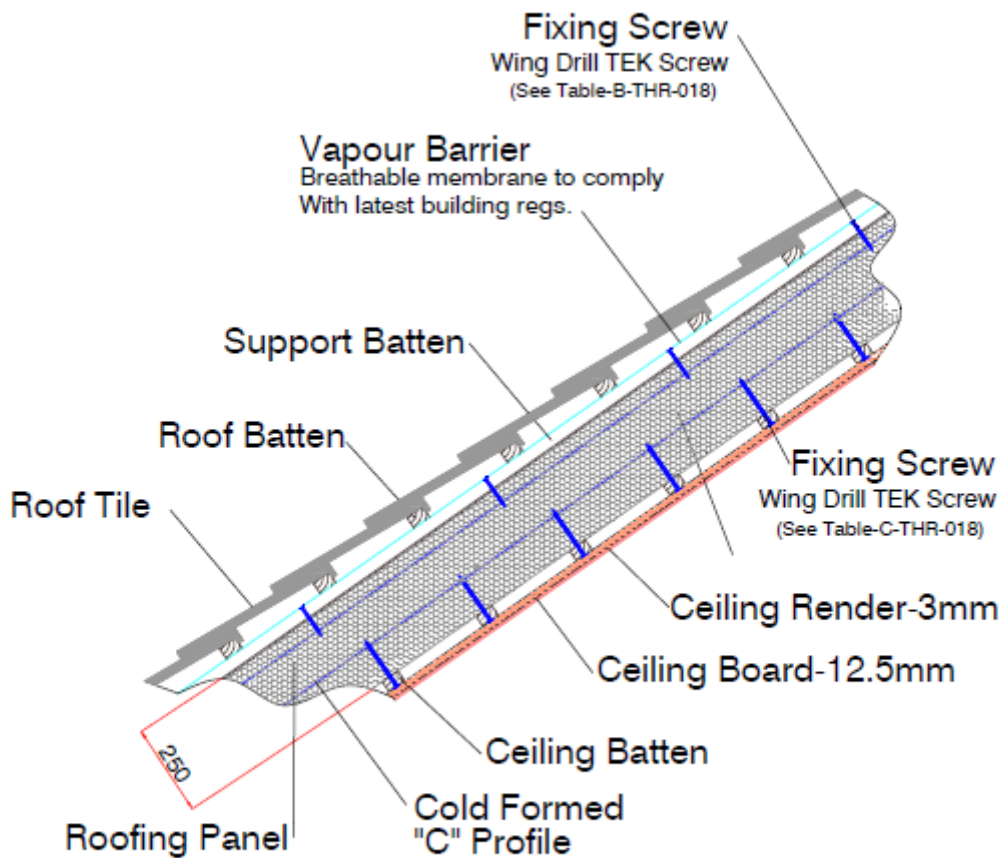

TR33 – Plasterboard fixed on Batten to Thermorof Typical Detail



Service Void Battens



Finished Ceiling



A gypsum plaster finish as shown below in figure TR-34 can be applied directly onto the Thermorooft panel however, It is required that this is a two coat application and a glass fiber 4mm mesh must be inserted into the first coat, screws are then inserted with the head standing proud for the second coat @ one/m2. Very good cross ventilation is required during the application and drying process of the plaster.

The plaster has to be finished with a sponge float/trowel to achieve an open cell finish to facilitate the drying process out through the surface of the plaster as there is **NO** soakage into the EPS.

This type of finish is not suitable in a damp or humid atmosphere as we have here in the British Isles and would not be recommended.

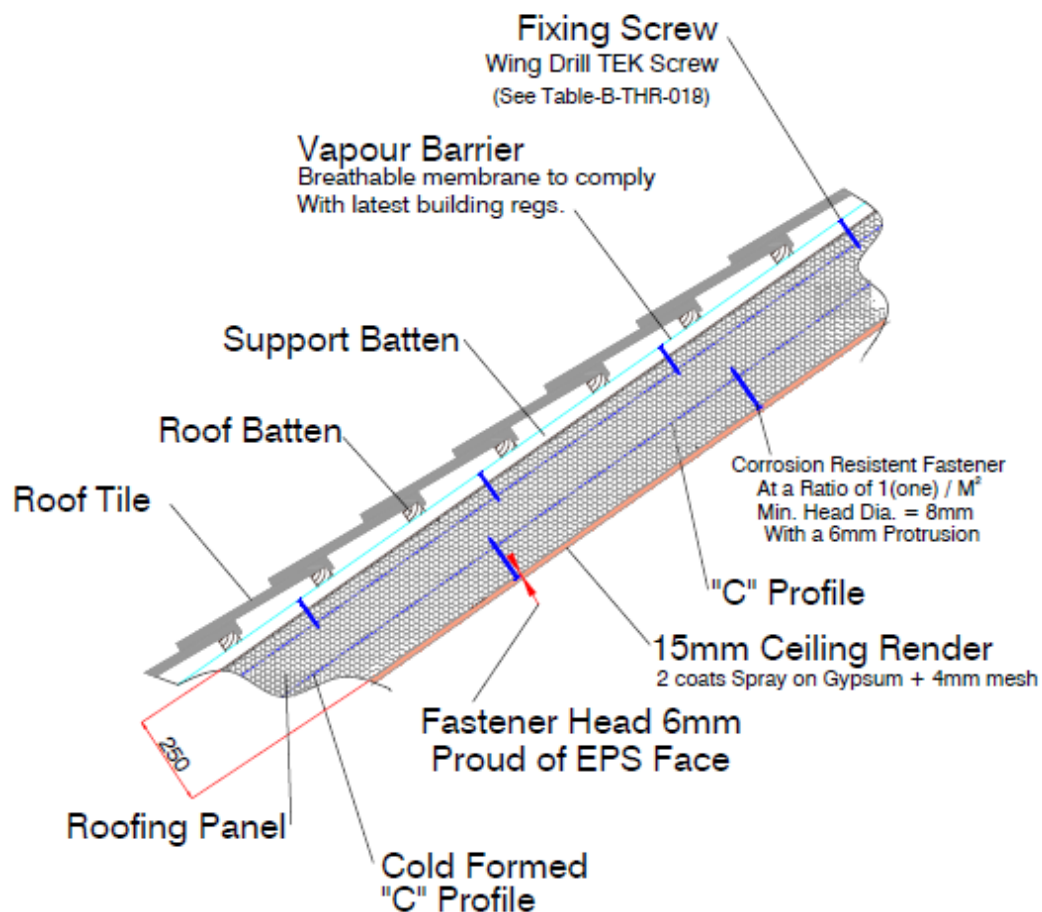

TR34 – Rendered Finish to Thermorooft Typical Detail

Zinc

For cutting the cold-formed sections, utilize either a "Large Blade Circular Saw" or a "Reciprocating Saw." After cutting, it is imperative to reinstate corrosion protection to the cut ends of all cold-formed sections. Exercise reasonable care to prevent any damage to the forms before, during, and after installation. Do not puncture, split, deform, or excessively compress the forms before their intended use.

The below photo's and sectional detail will demonstrate various fixing methods for these external finishes. Additionally, architects might recommend alternative systems. However, any systems used based on architect specifications must comply with the manufacturer's installation guidelines.

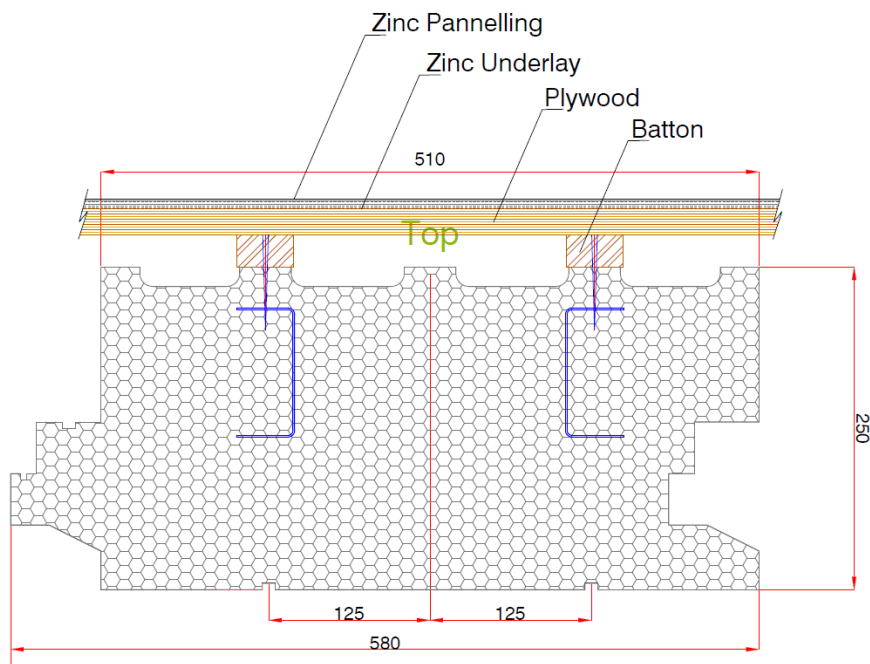

TR35 – Zinc Type Roof Finish Typical Detail



Solar Panels

The Thermorooft panel is adaptable for integrating solar panel systems. Structural engineers can utilise the Loading tables provided to perform calculations necessary for installing solar panels atop the roof panels.

Additional support might be necessary, and the structural engineer must consider this requirement.

The manufacturer of the solar panel systems should offer an installation method specific to the chosen system.



Openings & Services

1. Service penetrations for vents or extraction pipes should be placed between the cold-formed sections of a panel, avoiding the rebated joint between two panels. If the opening for a penetration clashes with a cold-formed "C" section, framing with inline timber trimmers similar to chimney and roof-light openings is necessary.
2. Proper means of natural or mechanical ventilation are essential to regulate air moisture or humidity in living spaces. The Thermohouse Roofing systems accommodate natural ventilation roof penetrations. Mechanical ventilation system ducting should be concealed within service ducts or voids. Avoid recessing ducting or services into the EPS of the Thermohouse Roofing system.
3. Use expanding foam and sealing tapes to restore full airtightness once service ducts or penetrations are installed.
4. Electrical cables in direct contact with EPS insulation should be made with migration-resistant plasticisers or placed within ducts/conduits to prevent plasticiser migration and cable degradation. Ensure cables are sized to minimize heat buildup and reduce fire risk according to regulations.
5. Electrical services can be housed within the void created by the timber battens on the roofing panels' soffits.
6. Limit chases made in the polystyrene and place them at appropriate distances from separating walls.
7. Recessed lighting in the Thermohouse Roofing system requires suitable precautions to prevent heat buildup in the EPS.

General Provisions

1. Ensure adequate separation between the Thermohouse Roofing panel and any heat sources like chimneys and flues.
2. Achieve airtightness in all Thermohouse Roof installations using jointing tape, adhesive foam, and isolated vapor barriers (where necessary). Avoid gaps between roofing planes and gable walls. If unavoidable, fill these gaps with an expanding foam or an air block foam of a similar thermal resistance ($0.030\text{W/m}^2\text{K}$) as the EPS used in the roofing panels. One can also apply jointing tape completely over the junction to maintain a confident airtightness.
3. Accommodate service penetrations within the zones between cold formed "C" sections of the Thermohouse Roofing panel. Seal any gaps around service penetrations and restore airtightness integrity.
4. Larger openings conflicting with the cold formed sections in the Thermohouse roofing panels should be trimmed out following the guidelines of figures 8, 10, and 11, as per the Supervising Engineer's directives if necessary.
5. Before installing roof underlay, ensure provision of all jointing tapes, cavity barriers, and fire stops.
6. Fix Thermohouse Roofing panels through both cold formed sections of each individual panel, ensuring fixing at all support points.
7. Avoid butt jointing or splicing panels along their length unless sufficient support is provided.



Thermorroof as a Flatroof

The ThermoRoof system offers versatility as a flat roof or a 0-degree system, allowing for the expansion of a passive-grade envelope. However, careful consideration of loadings, access, and area utilization is crucial.

These factors require assessment and approval by the Supervising Engineer. The unsupported span length might vary based on load factors and necessitates approval from the Supervising Engineer.

Furthermore, there's an option to rebate the support purlins and wall plates by 125mm to provide adequate support for the "C" sections within the panels.

Please consult the diagrams below, illustrating some typical section details.

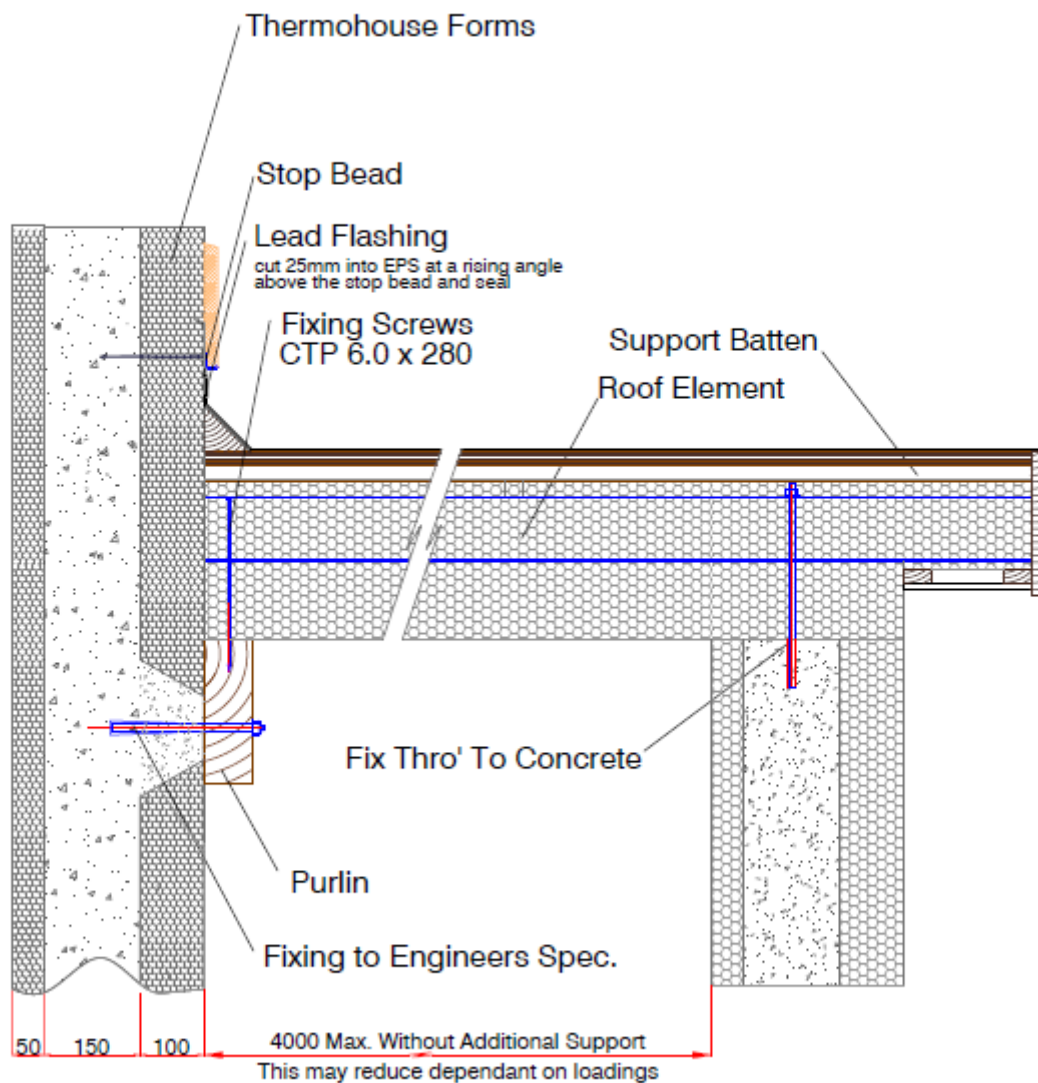

TR36 –Thermorroof Flat Roof With Overhang Typical Detail

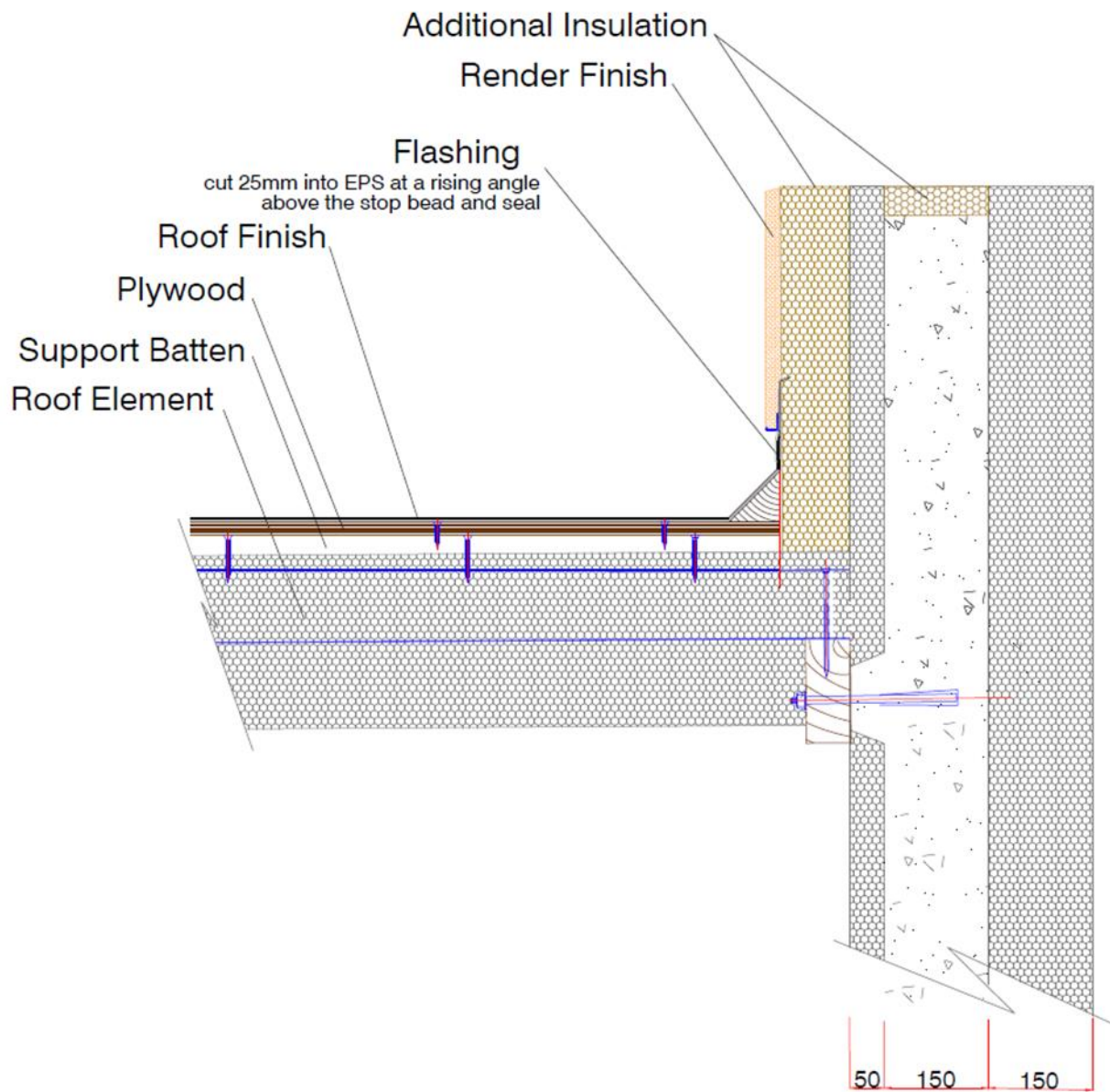

TR37 –Thermorroof Flat Roof With Parapet Wall Typical Detail

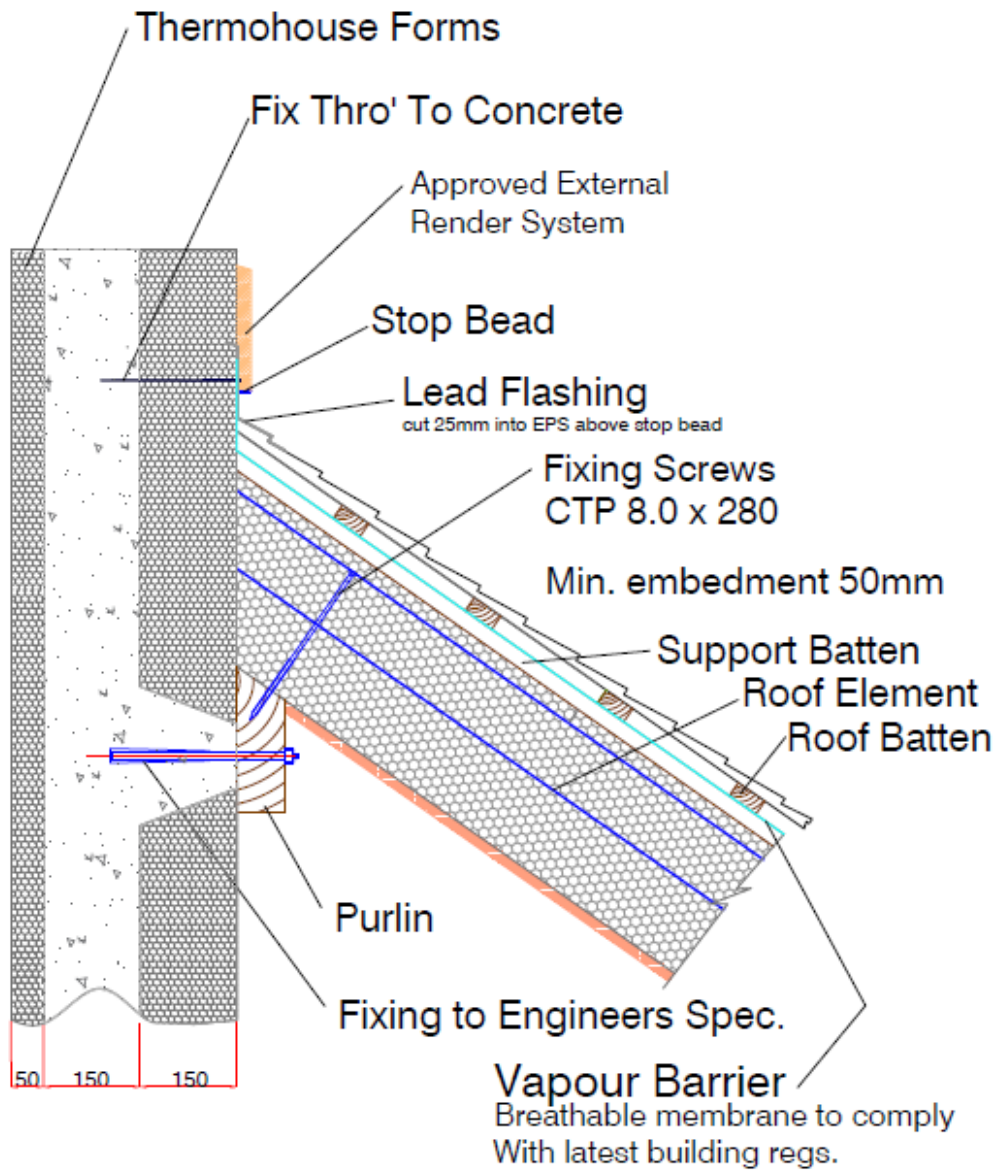

TR38 –ThermorooF Lean-to Roof Typical Detail



the complete low energy building system

Thermoboard

Thermoboard

Thermoboard is a specialised insulation board crafted specifically to optimize underfloor heating systems. Produced from expanded polystyrene (EPS), Thermoboard serves as an efficient thermal insulator, significantly boosting the effectiveness of underfloor heating arrangements.

Its robust build ensures longevity and even heat distribution, creating an ideal base for various floor finishes. This board is engineered to offer exceptional thermal conductivity, maximizing the efficiency of radiant heating systems while establishing a sturdy foundation for flooring applications.

This insulated floor panel has been ingeniously designed for underfloor heating. Its surface is molded to facilitate the clamping and easy fitting of underfloor heating pipes, allowing plumbers to directly install pipes without the need for rails or tracks. This innovation can drastically reduce installation time for underfloor heating pipes by up to 60%.



Thermoboard Elements

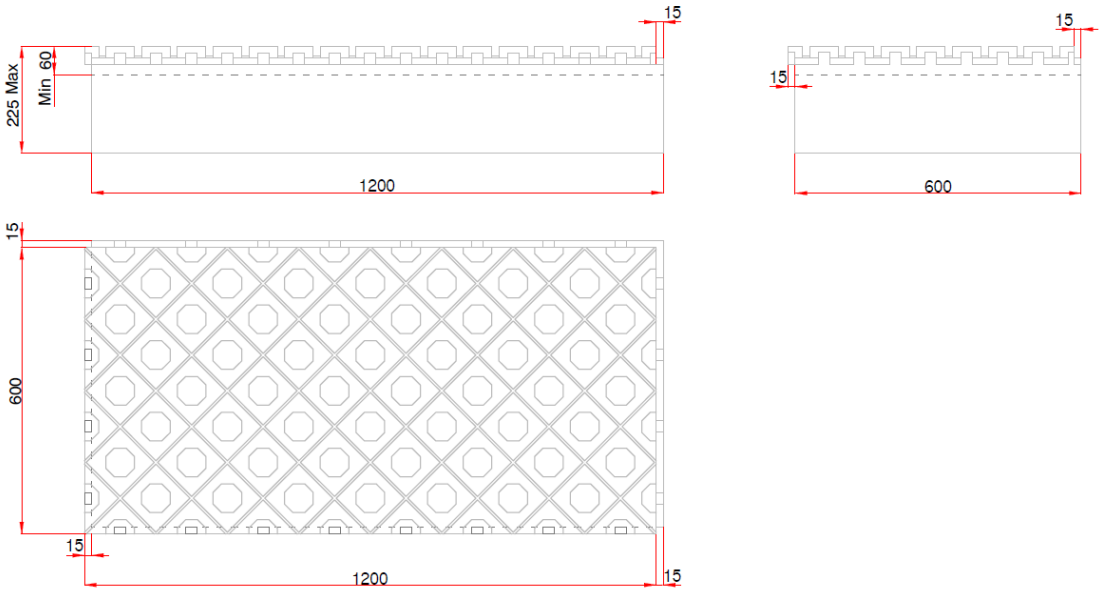

THB 60mm To 225mm
 1200mm x 600mm
 ($U=0.04 - 0.12W/m^2K$)
 Interlocking Ground
 Floor Insulation Element
 Available in Various Thicknesses

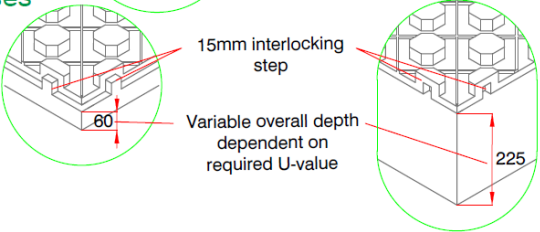
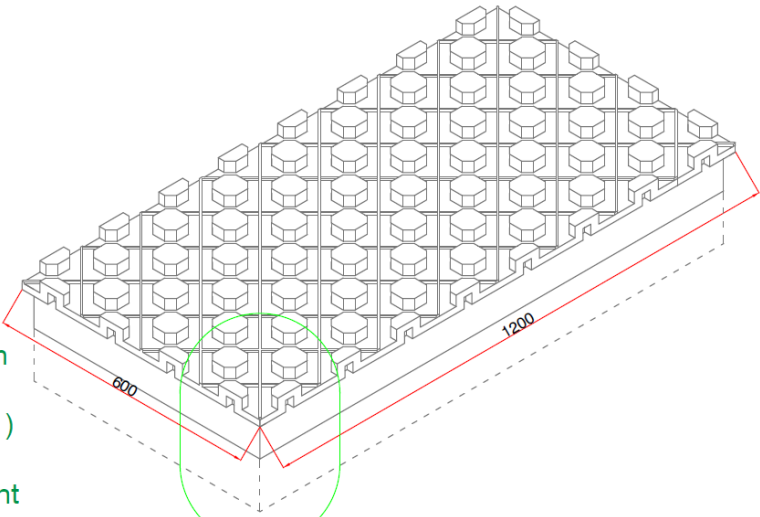

Thermoboard



The Thermoboard is an underfloor heating board, produced from EPS. The Thermoboard accommodates 16mm or 20mm heating pipes. The boards have an overlap on each joint which enables them to lock together during installation. These boards can be manufactured in thicknesses to suit customer specific requirements in increments of 5mm.

Size, Weight & Technical

Thermal Conductivity	0.030W/mK	
Density	24kg/m ³	
Board size (W x L)	600mm x 1200mm	
60mm Depth	0.68W/m ² K (U-Value)	1.21Kg/m ²
80mm Depth	0.45W/m ² K (U-Value)	1.81Kg/m ²
100mm Depth	0.33W/m ² K (U-Value)	2.10Kg/m ²
180mm Depth	0.15W/m ² K (U-Value)	4.10Kg/m ²
225mm Depth	0.12W/m ² K (U-Value)	5.50Kg/m ²

Fire Rating

External Fire Spread	Class 0
----------------------	---------

Materials

EPS

Commercial

Typical Use	Insulation for Ground Floor and Underfloor Heating
-------------	----------------------------------------------------

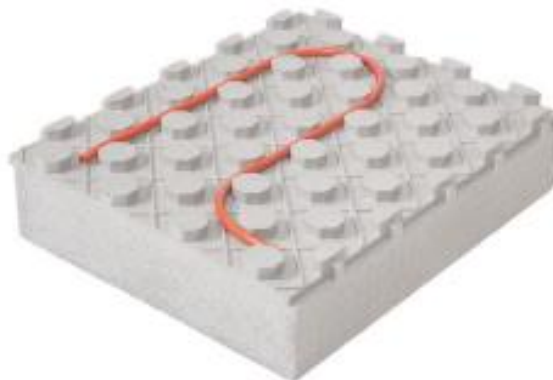

Contact Us

Phone: 0203 771 7426

Email: info@thermohouse.co.uk

Website: www.thermohouse.co.uk



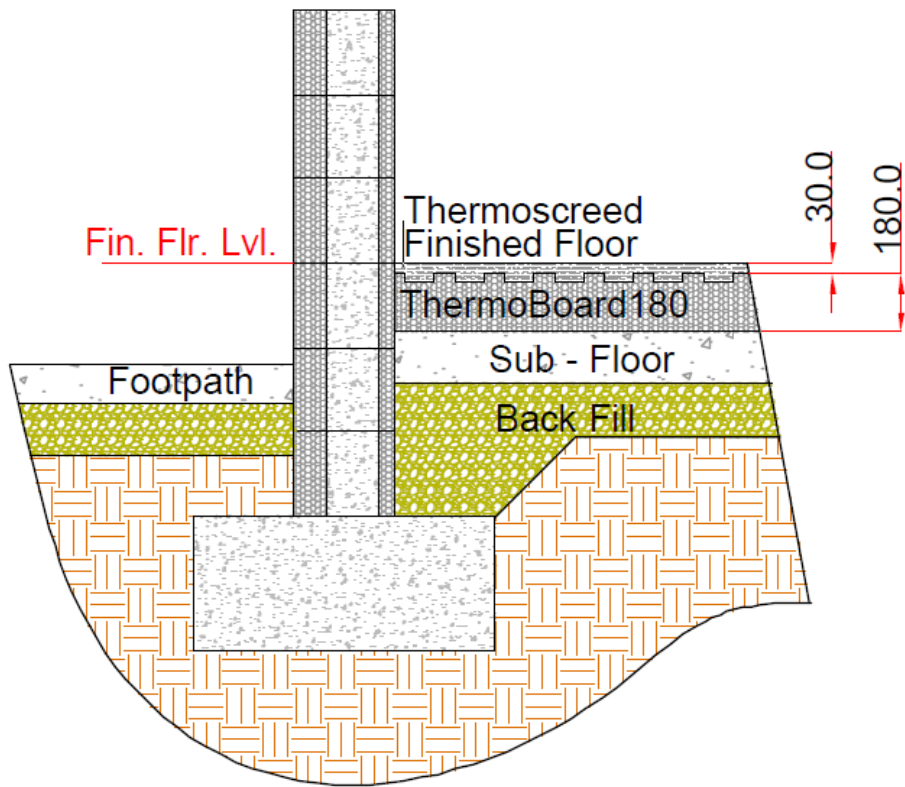

TB1 – 30mm Free Flow Thermoscreed Typical Detail

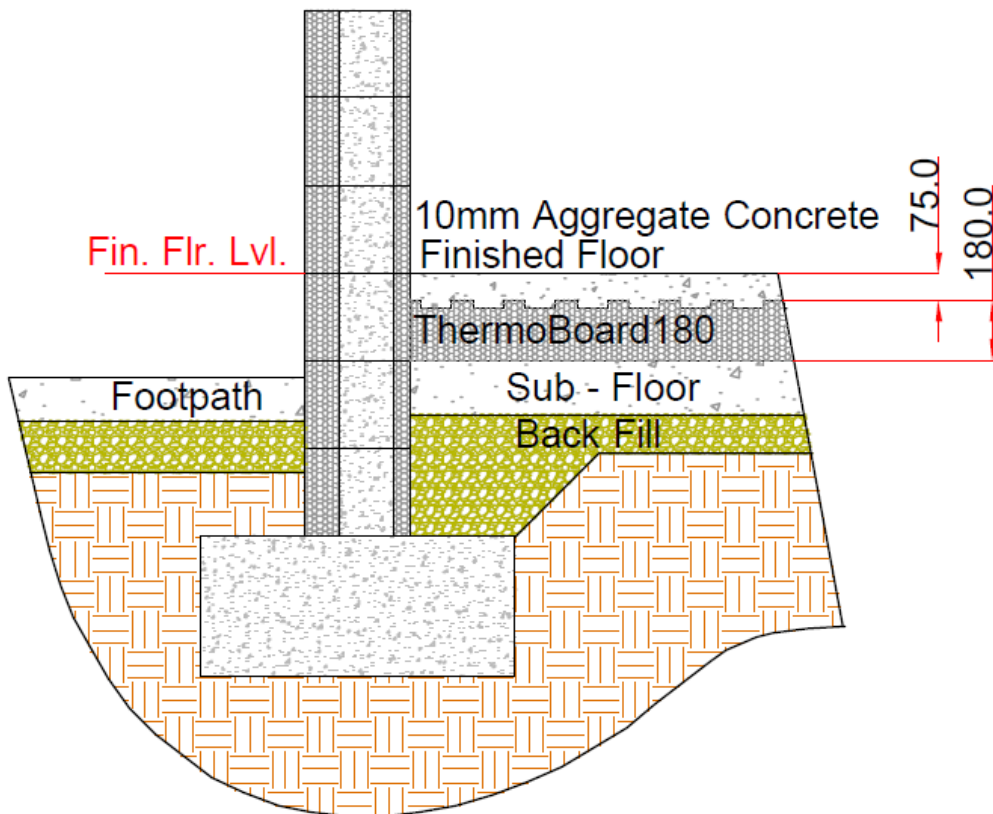

TB2 – 75mm Concrete Screed Typical Detail

Thermoboard Installation Steps

1. Ensure the subfloor is clean and level for proper interlocking and snug fitting into room corners.
2. Begin installation from a room corner and progress towards the opposite corner.
3. Trim off the interlocking overhang of boards bordering the edges to sit flush against outer walls. Use edge insulation for screed expansion and to prevent cold bridging with rising walls, if the rising walls use our Thermohouse System this edge insulation will not be required.
4. Interlock and fit all boards tightly in rooms without leaving gaps to maintain screed integrity.
5. Use off-cuts when reaching opposite corners to start installation in the next room.
6. Manually remove "Upstands / Mushrooms" from the board to accommodate pipes running closer together, especially near the system manifold.
7. Lay piping in a "Reverse Spiral" format for easy installation and even heat distribution. Attach retention clips into the board on the turn radius of pipes.
8. The boards accommodate domestic 16mm pipe at 150mm intervals and commercial 20mm pipe at 225-300mm intervals.
9. If possible, fill the underfloor system to prevent pipe lifting during screed installation.
10. After completion, place protective sheeting in main walkways to avoid "Upstands / Mushrooms" damage and remove loose debris rising during liquid screed pouring.







the complete low energy building system

Annex



Annex 1

300mm Thermowall Psi Values

		Summary of certified psi-values for use in SAP/DEAP/y-factor calculations. All calculations carried out in accordance with IS EN ISO 10211:2007 and BR497:2016. For more detailed information on application and relevant ranges of applicable U-values, see footnotes at the end of this table.			
		Date of issue:	23/01/2018		
		Revision no.:	1		
Target U-value: 0.19W/m ² K					
Detail number	Description	Psi value	fRsi value	Comment	
1.01	Strip foundation to external wall	0.084		0.92	
1.01A	Raft foundation to external wall	0.160		0.87	
1.02	Party wall in plan	0.049		0.94	Assign this psi value per dwelling in a DEAP/SAP/y-factor calculation
1.02A	Party wall in plan with SS fire break	0.078		0.93	Assign this psi value per dwelling in a DEAP/SAP/y-factor calculation
1.03	Internal partition in plan	0.035		0.94	
1.04A	Hollowcore intermediate floor within a dwelling	0.071		0.87	
1.04B	Timber intermediate floor within a dwelling	0.040		0.9	
1.04C	Thermofloor intermediate floor within a dwelling	0.055		0.83	
1.05	External wall corner	0.051		0.91	
1.06	Roof eaves standard roof on thermowall	0.034		0.91	
1.08	Window head	0.002		0.95	
1.09	Window jamb	0.002		0.95	
1.1	Window sill (concrete)	0.186		0.82	
1.11	Thermorooft wall eaves	0.005		0.94	
1.12	Thermorooft on cavity wall eaves	0.092		0.94	
1.12A	Thermorooft on cavity wall with Quinnlite B7 cavity closer	0.029		0.94	
1.13	Roof ridge	0.017		0.94	
1.14	Main wall to extension roof	0.095		0.95	
1.15	Main wall to lean-to roof	0.124		0.92	
1.16	Roof verge	0.030		0.91	
1.17	Main wall to flat roof	0.094		0.94	
1.18	Party wall roof head	0.026		0.96	Assign this psi value per dwelling in a DEAP/SAP/y-factor calculation
1.19	Door threshold	0.133		0.84	
1.2	Door head	-0.001		0.95	
1.21	Door jamb	-0.001		0.95	
Notes: The target U-value for the wall is 0.19W/m ² K. The target values for the roof and floor are 0.15W/m ² K and 0.14W/m ² K respectively. The psi-values are applicable for walls with U-values in the range of 0.15 - 0.21W/m ² K. Where two elements have one U-value above its target while another is below its target U-value, the aggregate percentage change from the respective target U-values in the table should not exceed 20% for the psi-value to be valid. For example, if the wall U-value were 0.21W/m ² K, which is 10% above the target value, the roof could not be below 0.135W/m ² K or the floor below 0.126W/m ² K in order for the psi-values to remain valid. Otherwise the aggregate difference about the target values would be greater than 20%. Where this is the case, the advice of the certificate holder should be sought, with project specific psi-values to be calculated.					

Annex 2



350mm Thermowall Psi Values

							
Passivate Energy Consultants Ltd. Rossana Cottage Ashford Co. Wicklow A67X329		Andrew Lundberg Passivate Registration Number #B/TM/02 NSAI Approved Thermal Modeller					
web tel e-mail	www.passivate.ie 00353-86-8843399 0044-208-1446946 andrew@passivate.ie						
Project Client Date Purpose	Thermohouse catalogue: external wall 350 mm; roof 250 mm Thermohouse 07/09/2020 Thermal performance calculation in accordance with BR 497 and BRE IP1/06						
Item description	Identifier	2D/3D	Psi-value (W/mK)	Junction Length (m)	fRsi-value	Compliant detail?	Report
Strip Foundation to External Wall	1.01	2D	0.102		0.93	Yes	Yes
Raft Foundation to External Wall	1.01A	2D	0.124		0.91	Yes	Yes
Party Wall in Plan	1.02	2D	0.069		0.96	Yes	Yes
Internal Partition in Plan	1.03	2D	0.020		0.96	Yes	Yes
Hollowcore Intermediate Floor	1.04A	2D	0.040		0.91	Yes	Yes
Timber Intermediate Floor	1.04B	2D	0.017		0.95	Yes	Yes
Termofloor Intermediate Floor	1.04C	2D	0.023		0.88	Yes	Yes
External Wall Corner	1.05	2D	0.048		0.93	Yes	Yes
Attic Eaves	1.06	2D	0.026		0.93	Yes	Yes
Window Head	1.08	2D	0.009		0.95	Yes	Yes
Window Jamb	1.09	2D	0.009		0.95	Yes	Yes
Window Cill	1.10	2D	0.064		0.92	Yes	Yes
Roof Eaves	1.11	2D	0.009		0.95	Yes	Yes
Roof Ridge	1.13	2D	0.013		0.95	Yes	Yes
Main Wall to Extension Roof Verge	1.14	2D	-0.053		0.97	Yes	Yes
Main Wall to Lean to Roof	1.15	2D	-0.022		0.95	Yes	Yes
Roof Verge	1.16	2D	0.029		0.93	Yes	Yes
Main Wall to Flat Roof	1.17	2D	-0.051		0.96	Yes	Yes
Party Wall - Roof	1.18	2D	0.046		0.97	Yes	Yes
Door Threshold	1.19	2D	-0.124		0.93	Yes	Yes
Door Head	1.20	2D	0.005		0.95	Yes	Yes
Door Jamb	1.21	2D	0.005		0.95	Yes	Yes
Party Wall - Raft Foundation	1.30	3D	0.165		0.89	Yes	Yes
Internal Wall - Raft Foundation	1.31	3D	0.257		0.89	Yes	Yes
Party Wall - Strip Foundation	1.32	3D	0.113		0.87	Yes	Yes
Internal Wall - Strip Foundation	1.33	3D	0.192		0.86	Yes	Yes
Intermediate Floor at Eaves	1.34	2D	0.134		0.90	Yes	Yes
Rooflight	1.35	2D	0.052		0.79	Yes	Yes

Notes: The target U-value for the wall is 0.15W/m²K. The target values for the roof and floor are 0.15W/m²K and 0.14W/m²K respectively. The psi-values are applicable for walls with U-values in the range of 0.12 - 0.17W/m²K. Where two elements have one U-value above its target while another is below its target U-value, the aggregate percentage change from the respective target U-values in the table should not exceed 20% for the psi-value to be valid. For example, if the wall U-value were 0.165W/m²K, which is 10% above the target value, the roof could not be below 0.135W/m²K or the floor below 0.126W/m²K in order for the psi-values to remain valid. Otherwise the aggregate difference about the target values would be greater than 20%. Where this is the case, the advice of the certificate holder should be sought, with project specific psi-values to be calculated.

Annex 3

Thermowall 450mm Psi Values

						
Passivate Energy Consultants Ltd. Suite 4 Abbey Offices Abbey St. Co. Wicklow A67 XV50		Andrew Lundberg Passivate Registration Number IAB/TM/02 NSAI Approved Thermal Modeller				
web tel e-mail	www.passivate.ie 00353-86-8843399 0044-208-1446946 andrew@passivate.ie					
Project Client Date Purpose	Passive Platinum Wall Block Catalogue Thermohouse 29/03/2023 Thermal performance calculation in accordance with BR 497 and BRE IPI/06					
Item description	Identifier	2D/3D	Psi-value	fRsi-value	Compliant detail?	Report
Strip Foundation to External Wall	1.01	2D	0.116	0.92	Yes	Yes
Raft Foundation to External Wall	1.01A	2D	0.142	0.90	Yes	Yes
Party Wall in Plan	1.02	2D	0.042	0.97	Yes	Yes
Internal Partition in Plan	1.03	2D	0.009	0.97	Yes	Yes
Hollowcore Intermediate Floor	1.04A	3D	0.052	0.94	Yes	Yes
Timber Intermediate Floor	1.04B	2D	0.008	0.96	Yes	Yes
Termofloor Intermediate Floor	1.04C	2D	0.045	0.92	Yes	Yes
External Wall Corner	1.05	2D	0.043	0.95	Yes	Yes
Inverted Wall Corner	1.05B	2D	-0.068	0.98	Yes	Yes
Attic Eaves	1.06	2D	0.034	0.93	Yes	Yes
Window Head	1.08	2D	0.025	0.96	Yes	Yes
Window Jamb	1.09	2D	0.024	0.96	Yes	Yes
Window Cill	1.10	2D	0.086	0.92	Yes	Yes
Roof Eaves	1.11	2D	0.016	0.96	Yes	Yes
Main Wall to Extension Roof Verge	1.14	2D	-0.060	0.97	Yes	Yes
Main Wall to Lean to Roof	1.15	2D	-0.035	0.95	Yes	Yes
Roof Verge	1.16	2D	0.031	0.94	Yes	Yes
Main Wall to Flat Roof	1.17	2D	-0.059	0.96	Yes	Yes





BRE Client Report

**Field Sound Insulation Acoustic Testing at 1 Watford Road,
Canning Town to BS EN ISO 140-4 , BS EN ISO 140-7 and BS EN
ISO 140-5**

Prepared for: Thermohouse
Date: 7th June 2016
Report Number: P104618-1001 Issue: 1

BRE
Watford, Herts
WD25 9XX

Customer Services 0333 321 8811

From outside the UK:
T + 44 (0) 1923 664000
F + 44 (0) 1923 664010
E enquiries@bre.co.uk
www.bre.co.uk

Prepared for:
Thermohouse
Coolcaslagh
Killamey
Co. Kerry



0578



BRE Client Report

**Field Sound Insulation Acoustic Testing at 1 Watford Road,
Canning Town to BS EN ISO 140-4 , BS EN ISO 140-7 and BS EN
ISO 140-5**

Prepared for: Thermohouse
Date: 23rd June 2016
Report Number: P104618-1002 Issue: 1

BRE
Watford, Herts
WD25 9XX

Customer Services 0333 321 8811

From outside the UK:
T + 44 (0) 1923 664000
F + 44 (0) 1923 664010
E enquiries@bre.co.uk
www.bre.co.uk

Prepared for:
Thermohouse
Coolcaslagh
Killarney
Co. Kerry

Annex 6

Air Permeability Testing – Sample report (completed Project)

Registered Air Permeability



Test

Test	Air Tightness
Address	8 Wroxham Close, Leigh-on-Sea,
Tested by	Andrew
Qualification	Level
Tester ID	000
Unique ID	101523

Building and Test

Building or Tested Building	TW10 6DF
Footprint (GFA)	16
Envelope Area	67
Date of Test	2016-

Temporary

SEALED ALL

Deviation

NON

Mastic Sealing

External and Internal Walls (inc.

Test Data and

This is to certify that the above named dwelling/building has been tested for air permeability by a registered {ATTMA TSLT (Method B)}, subject to the above statements regarding temporary. This certificate is a short form report. If a full compliant report is required, please contact the testing company. Enquiries to: Scheme Manager, ATTMA, St Mary's Court, The Broadway, Amersham, HP7

The key Leakage characteristics of the

Result	3.3m ³ .h ⁻¹ .m ⁻² @
The result achieved meets the Design Air	

Design air	5.0m ³ .h ⁻¹ .m ⁻² @	Flow	0.99
Correlation of	0.990	Air flow	46.m ³ .h ⁻¹

Annex 7

Energy Performance Certificate – Sample report (completed project)

Energy Performance Certificate

TW10 6DF

Dwelling type: Detached house **Reference number:** 9136-3879-7799-9806-9595
Date of assessment: 01 November 2016 **Type of assessment:** SAP, new dwelling
Date of certificate: 01 November 2016 **Total floor area:** 285 m²

Use this document to:

- Compare current ratings of properties to see which properties are more energy efficient

Estimated energy costs of dwelling for 3 years: £ 2,349

Estimated energy costs of this home			
	Current costs	Potential costs	Potential future savings
Lighting	£ 324 over 3 years	£ 324 over 3 years	Not applicable
Heating	£ 1,656 over 3 years	£ 1,656 over 3 years	
Hot Water	£ 369 over 3 years	£ 369 over 3 years	
Totals	£ 2,349	£ 2,349	

These figures show how much the average household would spend in this property for heating, lighting and hot water. This excludes energy use for running appliances like TVs, computers and cookers, and any electricity generated by microgeneration.

Energy Efficiency Rating

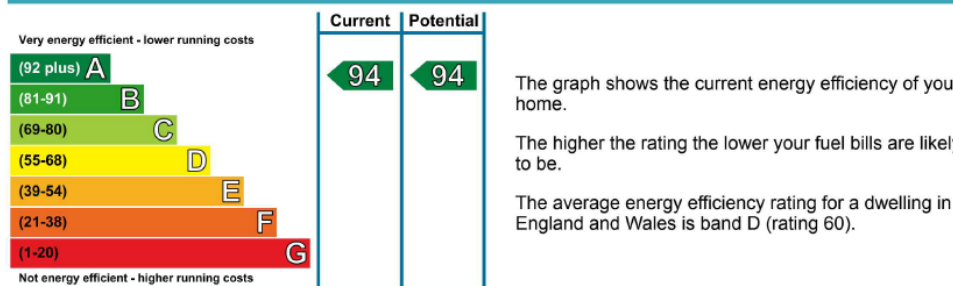

TW10 6DF
Energy Performance Certificate

Summary of this home's energy performance related features

Element	Description	Energy Efficiency
Walls	Average thermal transmittance 0.15 W/m ² K	★★★★★
Roof	Average thermal transmittance 0.13 W/m ² K	★★★★★
Floor	Average thermal transmittance 0.08 W/m ² K	★★★★★
Windows	High performance glazing	★★★★★
Main heating	Boiler & underfloor, mains gas	★★★★☆
Main heating controls	Time and temperature zone control	★★★★★
Secondary heating	None	—
Hot water	From main system	★★★★☆
Lighting	Low energy lighting in all fixed outlets	★★★★★
Air tightness	Air permeability 3.3 m ³ /h.m ² (as tested)	★★★★☆

Thermal transmittance is a measure of the rate of heat loss through a building element; the lower the value the better the energy performance.

Air permeability is a measure of the air tightness of a building; the lower the value the better the air tightness.

Current primary energy use per square metre of floor area: 23 kWh/m² per year

Low and zero carbon energy sources

Low and zero carbon energy sources are sources of energy that release either very little or no carbon dioxide into the atmosphere when they are used. Installing these sources may help reduce energy bills as well as cutting carbon. The following low or zero carbon energy sources are provided for this home:

- Solar photovoltaics

Recommendations

None.

Annex 8

Annex 9

NSAI Agrément Thermohouse ICF System Certification

(Full document available on request)



CUSIB (21.9) (Hn7)

CERTIFICATE NO. 08/0310

Thermohouse Ltd., Coolcaslagh,
Killamey, Co. Kerry.
Tel: 064 6631307
Fax: 064 6632394
Email: info@thermohouse.ie
Website: www.thermohouse.ie

Thermohouse ICF System

Système pour construction Bausystem

The Irish Agrément Board is designated by Government to issue European Technical Approvals.

Irish Agrément Board Certificates establish proof that the certified products are 'proper materials' suitable for their intended use under Irish site conditions, and in accordance with the Building Regulations 1997 to 2011.

The Irish Agrément Board operates in association with
the National Standards Authority of Ireland (NSAI) as the National Member of UEAtc.



PRODUCT DESCRIPTION:

This Certificate relates to the Thermohouse ICF (Insulating Concrete Formwork) System, which consists of modular interlocking expanded polystyrene (EPS) building blocks (standard white and grey) for permanent formwork for the construction of in-situ concrete walls. An external render system approved by NSAI Agrément for use with ICF systems is applied to the external polystyrene insulation of the Thermohouse ICF system as the external finish. Alternative finishes may be used in accordance with the Thermohouse ICF installation manual. Internally, the plasterboard is fixed directly through the EPS into the concrete core with plastic insulated anchors, or alternatively screwed to timber battens. An NSAI Agrément approved internal plaster may also be used as an alternative finish. This Certificate certifies compliance with the requirements of the Building Regulations 1997 to 2011.

USE:

The Thermohouse ICF System is certified for use in the construction of buildings up to six storeys in height.

The system has been assessed for use as load bearing and non-load bearing walls in the construction of specifically designed buildings. Fire and sound rated walls may also be constructed using the system.

MANUFACTURE AND MARKETING

The product is manufactured and marketed by:

Thermohouse Ltd.,
Coolcaslagh,
Killamey,
Co. Kerry.
Tel: 064 6631307
Fax: 064 6632394
Email: info@thermohouse.ie
Website: www.thermohouse.ie

Readers are advised to check that this Certificate has not been withdrawn or superseded by a later issue by contacting NSAI Agrément, NSAI, Santry, Dublin 9 or online at <http://www.nσαι.ie/modules/certificates/uploads/pdf/IAB080310.pdf>

Annex 10

NSAI Agrément Thermo House Roofing System Certification

(Full document available on request)



CI/SFB (21.9) (Hn7)

CERTIFICATE NO. 10/0349

Thermo House Ltd., Coolcaslagh,
Killamey, Co. Kerry.
Tel: 064 6631307
Fax: 064 6632394
Email: info@thermohouse.ie
Website: www.thermohouse.ie

Thermo House Roofing System

Système pour construction Bausystem

NSAI Agrément (Irish Agrément Board) is designated by Government to issue European Technical Approvals.

NSAI Agrément Certificates establish proof that the certified products are 'proper materials' suitable for their intended use under Irish site conditions, and in accordance with the **Building Regulations 1997 to 2009**



PRODUCT DESCRIPTION:

This Certificate relates to the Thermo House Roofing System, which consists of a composite steel cold-formed c-channel and interlocking expanded polystyrene (EPS) panels. The composite panels provide insulation and structural support to conventional slate and tiled roofing systems. The internal finishes to the composite panels can either take the form of a NSAI Agrément approved internal plaster for use with ICF (Insulating Concrete Formwork) systems or plasterboard slabs nail or screw fixed to timber battens which, in turn, are fixed to the bottom flange of the c-channels. This Certificate certifies compliance with the requirements of the Building Regulations 1997 to 2009.

USE:

The Thermo House Roofing System is certified for use in both domestic and commercial buildings

for all roof pitches between 17.5° to 60° pitches. Manufacturer's guidance should be sought for roof pitches outside of this range.

The system has been assessed for use as load bearing roofing panels which are simply supported on wall plates, ridge beams or intermittent purlins. The panels can be single or continuously spanning.

The roof panels are used as conventional roof rafters for traditional cut roof constructions supported on the primary support elements such as purlins and steel beams. The primary roof structure must cater for all wind uplift forces in addition to providing adequate triangulation and diagonal bracing. The Thermo House roof panel has not been assessed for use as an integral member in either trussed or framed roof designs.

Readers are advised to check that this Certificate has not been withdrawn or superseded by a later issue by contacting the NSAI Agrément, 1 Swift Square, Northwood, Santry, Dublin 9 or online at <http://www.nsal.ie/modules/certificates/uploads/pdf/AB100349.pdf>

Annex 12

BRE Thermorooft Load Testing (Full document available on request)



Testing of Thermohouse Roof Panels

Prepared for: Mr Jack O'Driscoll

Thermohouse Limited
Coolcaslagh
Killarney
Co. Kerry
Ireland

19 February 2009

Client report number 251-448

Annex 13

210mm Thermofloor element with Inserts thermal performance (full document available on request)



BRE Scotland
Scottish Enterprise Technology Park
Orion House
East Kilbride
G75 0RD

T +44 (0)1355 576200
F +44 (0)1355 576210
E eastkilbride@bre.co.uk
W www.bre.co.uk



Dony Kelly
Technical Support
Thermohouse Ltd
Coolcaslagh
Killarney
Co. Kerry

05 August 2015

Dear Dony

Thermohouse 210mm floor element with inserts

This letter reports the results from the thermal performance of a Thermohouse 210mm floor element with inserts.

Project Description and Context

BRE previously reported upon the thermal performance of the Thermohouse system, which included U-value calculations for a range of wall, floor and roof products. Thermohouse has requested that a modified floor element (210mm) is assessed with additional insulation inserts to improve thermal performance.

The representative thermal conductivities used in the model were taken from Annex A of BS EN ISO 10077-2 as detailed below in Table 1.

Material	Thermal conductivity (W/m·K)
Steel	50
Concrete	1.13
Insulation and inserts	0.029

Table 1 – Representative thermal conductivities

The position of the additional inserts is shown on the drawing in Appendix B.



BRE's Quality Management System is approved to BS EN ISO9001:2008, certificate number LRQ 4001797.



INVESTOR IN PEOPLE

Building Research Establishment Ltd, trading as BRE. Registered in England No 331 9324. Registered Office: Garston, Watford, WD25 9XX
BRE is wholly owned by a charity, the BRE Trust. All BRE profits are passed to the BRE Trust to promote its charitable objectives.

This calculation was undertaken for each of the flooring element, for an assumed standard floor configuration, with the following assumption made:

- Ratio of exposed perimeter to floor area (P/A) – 0.50
- Wall thickness – 300mm
- Depth of underfloor space – 200mm
- Concrete depth (minimum) – 125mm

The assessments were undertaken in compliance with:

- BR 443 Conventions for U-Value Calculations
- BR 497 Conventions for calculating linear thermal transmittance and temperature factors

Results

The results of the assessment are as follows:

Detail Ref.	U-value (W/m ² K)
210mm floor element	0.20
210mm floor element with additional inserts	0.18

Table 2 – 210mm floor element variations

Appendix A contains the output images from the thermal modelling of the junction details. The first image in each Figure shows the materials and thermal conductivities, with the second image showing the resulting temperatures.

Yours sincerely,



Graeme Hannah
Senior Consultant
For and on behalf of BRE
Telephone: +44 (0)1355 576225
E-mail: hannahg@bre.co.uk

Approved:

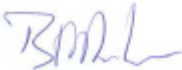

Brian Anderson
Technical Director, BRE Scotland

This letter is written on behalf of BRE. By receiving the letter and acting on it, the client - or any third party relying on it - accepts that no individual is personally liable in contract, tort or breach of statutory duty (including negligence).

Annex 14

BRE Thermowall & Thermorooft – Thermal Testing
(Full document available on request)



www.bre.co.uk

BRE Client Report

Review of thermal performance of updated Thermohouse system

Prepared for: Dony Kelly, Technical Support
Date: 23 October 2009 (Revised: 08 August 2019)
Report Number: 255996 Issue: 4.1

BRE
Watford, Herts
WD25 9XX

Customer Services 0333 321 8811

From outside the UK:
T + 44 (0) 1923 864000
F + 44 (0) 1923 864010
E enquiries@bre.co.uk
www.bre.co.uk

Prepared for:
Dony Kelly, Technical Support
Thermohouse
MC Group Ltd
Coolcaslagh
Killamey
Co. Kerry
Ireland

Annex 15

BRE Suspended Thermofloor & Flat Roof – Thermal Testing
(Full document available on request)



www.bre.co.uk

Certified Thermal Details and Products Scheme

Thermohouse Flat Roof and Floor Element Variations

Prepared for: **Dony Kelly, Technical Support**
Date: **8 May 2015**
Report Number: **HPR357-1000**

BRE Scotland
Orion House
Scottish Enterprise Technology Park
East Kilbride, Glasgow
G75 0RD

Customer Services 0333 321 8811

Scheme Technical Manager:
T + 44 (0) 1355 576200
F + 44 (0) 1355 576210
E certifiedthermalproducts@bre.co.uk
www.bre.co.uk/certifiedthermalproducts

Prepared for:
Dony Kelly, Technical Support, Thermohouse
Thermohouse
Coolcaslagh
Killamey
Kerry
Ireland

Annex 16

BRE Thermofloor as a Flatroof – Intersitial Condensation Report

(Full document available on request)

BRE
Watford, Herts
WD25 9XX

T +44 (0)1923 664000
F +44 (0)1923 664010
E enquiries@bre.co.uk
W www.bre.co.uk

bre

Dony Kelly
Technical Support
Thermohouse
Coolcaslagh
Killarney
Co. Kerry

22/01/2016
Your Ref. Thermohouse – Condensation risk analysis
Our Ref. P103405

Dear Dony,

Please find results for the Thermohouse Roof element interstitial condensation risk analysis project below.

Background

Two types of condensation can affect building details – condensation at an inside surface and interstitial condensation within a structure. Both types of condensation occur when the temperature falls too low in relation to vapour pressure.

- Surface condensation is a deposition of liquid water from a vapour, occurring on visible surfaces within the building. It can cause moulds to grow which pose a health hazard to occupants.

Surface condensation is assessed against the requirements set down in IP 1/06 and an assessment is carried out using the method in BS EN ISO 10211 and the conventions in BR 497.

- Interstitial condensation is deposition of liquid water from a vapour, occurring within or between the layers of the building envelope. It can cause damage to the structure and reduce the thermal performance of insulation.

It is assessed using the method in BS EN ISO 13788, using guidance in BS 5250, and involves a simplified calculation procedure, but it does require detailed information about any vapour control layer or ventilation within the structure – BRE has in-house software for assessing interstitial condensation.

Previous 3D thermal modelling had been undertaken for the Thermohouse roof element (Thermofloor used as a flat roof element), and no risk of surface condensation was identified.

BRE has been commissioned by Thermohouse to assess the interstitial condensation risk of the Thermohouse roof element, and determine if any additional insulation is required.



BRE's Quality Management System is approved to BS EN ISO9001:2008, certificate number LRQ 4001063.

BRE's Environmental Management System is approved to BS EN ISO14001:2004, certificate number LRQ 4001064.

Building Research Establishment Ltd, trading as BRE, Registered in England: No 331 9324. Registered Office: Garston, Watford, WD25 9XX
BRE is wholly owned by a charity, the BRE Trust. All BRE profits are passed to the BRE Trust to promote its charitable objectives.

BRE Template V1

Methodology

An assessment of the risk of interstitial condensation was undertaken.

This task involved assessing the layers of the roof construction using the criteria in BS 5250 and the calculation method in BS EN ISO 13788. This calculation provides the condensation rate for each month of the year (for a given climate) expressed in g/m². It also indicates where there is a year-on-year accumulation of moisture, and if any build up during the winter will evaporate in the summer months. This calculation is a one-dimensional calculation using information about the layers making up the wall, including materials and barriers or membranes used in the construction.

Results are presented for the typical worst year in a 10 year period (a 10 year return period as defined by BS 5250, using the Manchester climate). The calculation is done for the roof at different locations.

The calculation was undertaken at 3 points through the structure, as identified below:

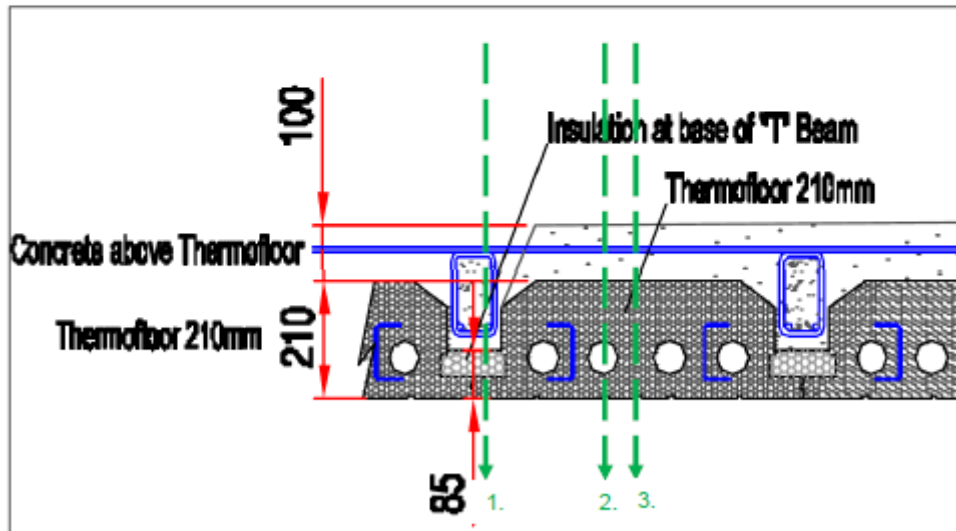

Figure 1 – Thermohouse Roof Element – Interstitial Condensation Risk Assessments

Interstitial Condensation Risk Results

The risks were assessed on the basis of a 10-year return period for the Manchester Climate. The results were as follows:

Reference	Risk?		
Detail 1 – through additional insert	At risk of condensation	✘	All months
Detail 2 – through void space	At risk of condensation	✘	Nov to June
Detail 3 – through 'typical' section	At risk of condensation	✘	Nov to May

Table 1 – Interstitial Condensation Risk Analysis

Through the calculations on the above details, it was determined that there is deemed to be risk of interstitial condensation for all details assessed using the one-dimensional calculation method.

As a result, an additional series of assessments were undertaken to determine the impact of additional insulation. Note: A minimum of **60mm of mineral wool insulation** (assumed at 0.04 W/m·K) was required to prevent interstitial condensation for all detail variations. See below:

Reference	Risk?	
Detail 1.1 – through additional insert	No risk of condensation	✓
Detail 2.1 – through void space	No risk of condensation	✓
Detail 3.1 – through 'typical' section	No risk of condensation	✓

Appendix A contains a full output of each calculation and a graphical representation respectively.



Graeme A. Hannah
Senior Consultant
For and on behalf of BRE
Telephone: +44 (0) 1355576200
Email: HannahG@bre.co.uk

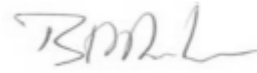

Approved by: Dr Brian Anderson
Technical Director
For and on behalf of BRE
Telephone: +44 (0) 1355576200
Email: AndersonA@bre.co.uk

References

- [1] BS EN ISO 13788: Hygrothermal performance of building components and building elements – Internal surface temperature to avoid critical surface humidity and interstitial condensation – Calculation methods
- [2] BS 5250: Code of practice for control of condensation in buildings

جمهوری اسلامی ایران
وزارت مسکن و شهرسازی
مرکز تحقیقات ساختمان و مسکن

شماره: ۱-۱۰۵۳۸
تاریخ: ۱۳۸۶/۱۲/۱۲

تأییدیه فنی

به استناد ماده ۲ وظایف قانونی مرکز تحقیقات ساختمان و مسکن، جزء ۲-۶ بند «د» تبصره ۶ قانون بودجه سال ۱۳۸۶ کل کشور و دستورالعمل‌های مربوطه، بر اساس بررسی‌های انجام شده و با شرط رعایت الزامات ذیل:

- سیستم سازه‌ای حاصل از این روش اجراء به عنوان سیستم سازه‌ای دیوار پارپر یا دیوارهای پرشی بتن مسلح محسوب می‌شود. در صورتی که ضوابط شکل‌پذیری بر اساس آیین‌نامه ۲۸۰۰ و میحت نهم مقررات ملی ایران رعایت نشود، با استناد به بند ۹-۲۰-۲-۵-۲ میحت نهم مقررات ملی ایران، کاربرد این سیستم صرفاً در مناطق یا خطر نسبی کم و متوسط و برای ساختمان‌های دارای اهمیت کم و متوسط تا حداکثر ارتفاع ۱۰ متر مجاز می‌باشد. بدیهی است در صورتی که ضوابط شکل‌پذیری رعایت شود، ضمن رعایت ضوابط مقاومت در برابر حریق، حداکثر ارتفاع ساختمان بر اساس ضوابط آیین‌نامه ۲۸۰۰ ایران، ۵۰ متر از تراز پایه می‌باشد.
- پارگذاری نقلی و لوله‌های سیستم سازه‌ای حاصل از این روش، باید به ترتیب بر اساس آخرین ویرایش‌های میحت ششم مقررات ملی ساختمان و استاندارد ۲۸۰۰ ایران صورت گیرد.
- طرح سازه‌ای سیستم حاصل از این روش، باید بر اساس میحت نهم مقررات ملی ساختمان یا آیین‌نامه ۲۱۸ -۰۵ ACI و ویرایش‌های بعد از آن صورت گیرد.
- ضخامت مفید دیوارهای بتنی نباید از ۱۵ سانتی‌متر کمتر باشد.
- بتن مصرفی باید از نوع بتن سازه‌ای و با حداقل مقاومت ۲۰MPa و حداکثر اندازه اسمی سنگدانه مصرفی، ۲۰ میلی‌متر باشد.
- مشخصات کلیه مصالح مصرفی مربوط به اجزاء قالب‌بندی ماندگار، باید مطابق با استانداردهای بین‌المللی معتبر و اسناد ارائه شده باشد. مشخصات سایر مصالح مصرفی نیز باید مطابق استانداردها و آیین‌نامه‌های ملی یا معتبر بین‌المللی باشد.
- مقاومت سیستم در برابر آتش (که وابسته به نوع و جزئیات دیوار است)، باید مطابق با الزامات میحت سوم مقررات ملی ساختمان و آیین‌نامه ۴۴۴ مرکز تأمین شود. مدرک ارائه شده توسط متقاضی صرف سیستمی با مقاومت ۹۰ دقیقه در برابر آتش است که برای ساختمان‌های بلند کافی نیست. برای مقاومتهای بالاتر به ضخامت‌های بیشتر دیوار بتنی نیاز می‌باشد.
- پلی‌استایرن باید از نوع کندسوز (خود خاموش شو) باشد (توجه: اصولاً استفاده از پلی‌استایرن منبسط‌شده معمولی در ساختمان مجاز نیست و حتماً همیشه فقط باید از نوع خود خاموش شو استفاده شود).
- پلی‌استایرن مورد استفاده باید مطابق با استانداردهای معتبر بین‌المللی و دارای گواهی‌نامه فنی از مرکز تحقیقات ساختمان و مسکن باشد.
- محافظت از بلوک پلی‌استایرن باید به وسیله پوشش و مانع حرارتی مناسب صورت گیرد. به عنوان مثال، می‌توان از یک اندود یا تخته گچی حدود ۱۳ میلی‌متر یا سایر مصالح که از نظر مقاومت در برابر دمای بالا، معادل آن باشد، استفاده نمود. پوشش محافظت‌کننده باید دارای اتصال مکانیکی به سازه باشد و چسباندن آن به پلی‌استایرن به تنهایی قابل قبول نیست. (توجه: در مفرک Thermohaus / ۰۸/۰۳۱۰ IAB به پوشش‌های تائید شده برای این کار اشاره شده است که متقاضی می‌تواند مشخصات آنها را از تولیدکننده اصلی تهیه نماید).
- توجه به نکات فنی ذکر شده در مدارک ETA-۰۵/۰۱۷۰ و Thermohaus / ۰۸/۰۳۱۰ IAB که توسط متقاضی پیوست شده است، ضروری است.
- لایه پلی‌استایرن بین واحدهای مستقل، نباید امتداد داشته باشد و حتماً باید به وسیله مصالح غیر قابل سوختن با مقاومت کافی در برابر آتش قطع شود.





بلدية مدينة أبوظبي
MUNICIPALITY OF ABU DHABI CITY

الرقم: ق ت م / ت ب / ٤٤٥
التاريخ: ٨ / ٥ / ٢٠١١ م

السادة / شركة ثيرموهاوس (Thermohouse) للمقاولات العامة
المحترمين
ابوظبيي ص . ب ٤٦٥٤٩
فاكس: ٦٣٣٦٥٥٢ - ٠٢ ت: ٦٣٣٧٧١٦ - ٠٢
تحية طيبة وبعد،،،

الموضوع: طلب اعتماد نظام ثيرموهاوس لإنشاء المباني
Thermo House ICF System

بالإشارة لخطابكم الوارد إلينا بتاريخ ٢٠١١/٣/١٦ بخصوص الموضوع أعلاه فقد تم مراجعة المواصفات الفنية المقدمة من قبلكم بخصوص نظام الإنشاء المذكور أعلاه وقد تبين أن هذا النظام عبارة عن قوالب دعم دائمة (Permanent Formwork) مصنوعة من البوليستيرين الممدد (expanded polystyrene) تستخدم في المنشآت الخرسانية وتبقى في مكانها بعد صب الخرسانة ولا يتم إزالتها بعد تصلب الخرسانة وتعتبر جزء من العنصر الإنشائي المستخدمة به وتستخدم هذه القوالب عادة في الأسقف والجوانب الحاملة والغير حاملة، المسلحة والغير مسلحة.

وحيث أنه تم اعتماد هذا النظام من قبل المنظمة الأوروبية للاعتمادات الفنية (European Organization for Technical approvals (EOTA) الصادر عنه برقم (ETA - 09/0083) بتاريخ ٢٠٠٩/٣/٢ فلا مانع لدينا من استخدام هذا النظام على أن يتم مراعاة الشروط الآتية:

١. الالتزام بجميع متطلبات وشروط الاستخدام الواردة في الوثيقة المذكورة أعلاه.
٢. أن يتم الحصول على موافقة الدفاع المدني في ابوظبيي .
٣. أن يتم تقديم كل مشروع على حده من خلال مكتب استشاري مرخص ومعتمد في ابوظبيي.
٤. أن يتم تقديم حسابات التصميم الإنشائي والرسومات والتفاصيل من قبل مهندس مؤهل ومعتمد وذلك حسب كود البناء الدولي (IBC 2009).

وتقبلوا التحية ،،،

بلدية أبوظبي
قطاع تخطيط المدن
إدارة تراخيص البناء
المهندس / خلفان سلطان النعيمي
مدير إدارة تراخيص البناء
قطاع تخطيط المدن

Annex 19

Reaction to Fire report

(Full document available on request)



Order no.: Z210180424

PAVUS, a.s.

AUTHORIZED BODY AO 216
NOTIFIED BODY 1391
EGOLF MEMBER



FIRE TESTING LABORATORY VESELÍ NAD LUŽNICÍ
Testing Laboratory No. 1026 accredited by ČIA
Notified Testing Laboratory
Workplace Veselí nad Lužnicí

REACTION TO FIRE TEST REPORT

No. Pr-18-1.229-En

Issued on 2018-11-16

for product

**Expanded polystyrene shuttering
element board - type TH8**

Sponsor: **THERMOHOUSE LTD**
Coolcaslagh, Killarney
CO Kerry
Ireland

Test method:

EN ISO 11925-2
» Reaction to fire tests - Ignitability of building products
subjected to direct impingement of flame
- Part 2: Single-flame source test «

The Report contains: 6 pages
(4 text pages + 2 annexes)

Number of copies: 3
Copy No.: 1

The report may not be reproduced other than in full, except with the written approval of testing laboratory.

Prosecká 412 / 74, 190 00 Prague 9 – Prosek, Czech Republic, mail to: mail@pavus.cz, <http://www.pavus.cz>
CIN: 60193174, TIN: CZ60193174, in Commercial Register of the Municipal Court in Prague, section B, inset 2309
Phone: +420 286 019 587, Fax: +420 286 019 590
Branch Veselí nad Lužnicí,
Čtvrť J. Hybeše 878, 391 81 Veselí nad Lužnicí, Czech Republic, mail to: veseli@pavus.cz
Phone: +420 381 477 418, Fax: +420 381 477 419

Annex 20

Reaction to Fire report

(Full document available on request)



PAVUS, a.s.

AUTHORIZED BODY 216
NOTIFIED BODY 1391
ACCREDITED CERTIFICATION BODY FOR
PRODUCTS N° 3041

Branch: FIRE TESTING LABORATORY
VESELÍ NAD LUŽNICÍ
Čtvrť J. Hybeše 879
CZ 391 81 Veselí nad Lužnicí
Czech Republic

Address:
Prosecká 412/74, CZ 190 00 Praha 9 – Prosek
Tel.: +420 286 019 587 Fax: +420 286 019 590
E-mail: mail@pavus.cz, http://www.pavus.cz

Tel.: +420 381 477 418
Fax: +420 381 477 419
E-mail: veseli@pavus.cz

FIRE RESISTANCE CLASSIFICATION REPORT

Subject of classification: *Loadbearing walls with fire separating function according to ČSN EN 13501-2:2017, cl. 7.3.2*

Identification number: **PK2-02-05-015-A-2**

Name and type of element: *Peripheral wall THERMOMUR – 250
GKF slabs 12.5 mm on internal side
mineral plaster on external side
(exposed to heat from both sides)*

Sponsor: **THERMOHOUSE LTD.**
*Coolcaslough Killarney
CO Kerry
Ireland*

Issuing organization: **PAVUS, a.s.**
*Authorized Body 216
Notified Body 1391
Accredited certification body for products certification N° 3041
- Accreditation issued by Czech Accreditation Institute, Public
Service Company
- Certificate of Accreditation N° 762/2017*

*Prosecká 412/74
190 00 PRAHA 9*

Order N° Z210180433 (Z210130044)

Date of issue: *2019-01-17*

Copies in total: *4*

Copy number: *4*

Pages in total: *5*

Annex 21

Council of Mortgage Lenders letter



Christopher Stride
Insulating Concrete Formwork Association
Thermal House
PO Box 72
Billingshurst
West Sussex
RH14 0FD

13 September 2012

Dear Christopher

Insulating Concrete Formwork

I write to you on behalf of the Valuation Panel of the Council of Mortgage Lenders to confirm the following statement:

FEBRUARY 2010. The Valuation Panel of the Council of Mortgage Lenders confirmed that ICF (Insulating Concrete Formwork) construction is acceptable for mortgage purposes as a standard form of construction, subject to provision of valid product certification and monitoring of ICF System providers by the ICFA (Insulating Concrete Formwork Association) of the UK.

The lending decision is always at the discretion of the mortgage lender advancing the funds.

Yours sincerely

A handwritten signature in black ink, appearing to read 'Jennifer Bourne', is written over a light blue horizontal line.

Jennifer Bourne
Senior Policy Advisor
020 7438 8989
Jennifer.bourne@cml.org.uk

Annex 22

BBA Letter



British Board of Agrément
1st floor, Building 3
Hatters Lane
Croxley Park
Watford
WD18 8YG

T: +44 (0) 1923 665300
E: clientservices@bbacerts.co.uk
W: www.bbacerts.co.uk

Our Reference S168203

Contact Name Mr E Dunne
Company Name Thermo House Ltd
Address Coolcaslagh
Kilkamey
Ireland

Date 11th October 2022

Dear Mr Dunne,

S168203 – Thermohouse ICF (Insulating Concrete Formwork) System

This letter is to confirm that the BBA is in contract to carry out a technical assessment of the above system.

The work is not yet complete and so no conclusions can be drawn. Should the outcome of the assessment be favourable, it is anticipated that a draft BBA Certificate will be forwarded to the BBA's Chief Executive for approval to issue in due course.

Yours sincerely



Richard Payne
Head of Sales
M +44 (0) 7918 317668
E rpayne@bbacerts.co.uk

The UK Representative in the UEAtc (European Union of Agrément). UKAS Accredited Testing Laboratory No. 0357 / Certification Body No. 0113 / Inspection Body No. 4345
British Board of Agrément, a company limited by guarantee, registered in England No 873293.
Registered Office: British Board of Agrément, 1st floor, Building 3, Hatters Lane, Croxley Park, Watford, WD18 8YG





Declaration Of Performance (DOP)

250mm EPS Roof Elements, (250mm High x 510mm Wide).

DOP Ref:	<i>THDOP-00010</i>	EU Directive:	<i>ISEN 13163:2012+A1:2015</i>
----------	--------------------	---------------	--------------------------------

Company Name:	<i>Thermohouse Ltd</i>
Place Of Manufacture:	<i>Coolcaslagh, Killarney, Co Kerry, Rep Of Ireland</i>

Product Description:	<i>250mm EPS Roof Elements, (250mm High x 510mm Wide).</i>
Intended Use:	<i>For installation as an external thermal roof system, cut to customer specified lengths and used on private and commercial dwellings.</i>

Essential Characteristics:	Performance	Test Standard
<i>Declared Thermal Conductivity</i>	<i>0.030 W/mK</i>	<i>IS EN 12667</i>
<i>Declared Thermal Resistance</i>	<i>7.833 m2k/W</i>	<i>IS EN 12667</i>
<i>Compressive Strength at 10% Deformation</i>	<i>150 kN/m2</i>	<i>IS EN 826</i>
<i>EPS Density</i>	<i>Min 24kg/m3</i>	<i>IS EN 1602</i>
<i>Reaction to Fire</i>	<i>B1</i>	<i>DIN 4102</i>
<i>Water Vapour Diffusion Resistance Factor</i>	<i>μ = 51.4, sd = 2m</i>	<i>IS EN 12086</i>

Durability:	<i>This wall system when installed in accordance with the technical instructions as supplied by the manufacturer will achieve the values declared in this DOP.</i>
-------------	--------------------------------------------------------------------------------------------------------------------------------------------------------------------

Release of dangerous substances & emissions.	<i>MSDS information can be supplied on demand in the standard industrial format.</i>
----------------------------------------------	--------------------------------------------------------------------------------------

Signed on behalf of the manufacturer:		Full Name:	<i>Michael Cronin</i>
---------------------------------------	-------------------------------------------------------------------------------------	------------	-----------------------

Position Held:	<i>Managing Director</i>	Issue Date:	<i>15/04/2015</i>
----------------	--------------------------	-------------	-------------------

Annex 24

160 Floor CE Mark & DOP



Declaration Of Performance (DOP)

160mm EPS Floor Elements, (160mm High x 600mm Wide).

DOP Ref:	<i>THDOP-00011</i>	EU Directive:	<i>ISEN 13163:2012+A1:2015</i>
----------	--------------------	---------------	--------------------------------

Company Name:	<i>Thermohouse Ltd</i>
Place Of Manufacture:	<i>Coolcaslagh, Killarney, Co Kerry, Rep Of Ireland</i>

Product Description:	<i>160mm EPS Floor Elements, (160mm High x 600mm Wide).</i>
Intended Use:	<i>For installation as an internal non-load bearing thermal floor system, cut to customer specified lengths and used on private and commercial dwellings.</i>

Essential Characteristics:	Performance	Test Standard
<i>Declared Thermal Conductivity</i>	<i>0.030 W/mK</i>	<i>IS EN 12667</i>
<i>Declared Thermal Resistance</i>	<i>4.762 m²k/W</i>	<i>IS EN 12667</i>
<i>Compressive Strength at 10% Deformation</i>	<i>150 kN/m²</i>	<i>IS EN 826</i>
<i>EPS Density</i>	<i>Min 24kg/m³</i>	<i>IS EN 1602</i>
<i>Reaction to Fire</i>	<i>B1</i>	<i>DIN 4102</i>
<i>Water Vapour Diffusion Resistance Factor</i>	<i>μ = 51.4, sd = 2m</i>	<i>IS EN 12086</i>

Durability:	<i>This wall system when installed in accordance with the technical instructions as supplied by the manufacturer will achieve the values declared in this DOP.</i>
-------------	--------------------------------------------------------------------------------------------------------------------------------------------------------------------

Release of dangerous substances & emissions.	<i>MSDS information can be supplied on demand in the standard industrial format.</i>
----------------------------------------------	--------------------------------------------------------------------------------------

Signed on behalf of the manufacturer:		Full Name:	<i>Michael Cronin</i>
---------------------------------------	-------------------------------------------------------------------------------------	------------	-----------------------

Position Held:	<i>Managing Director</i>	Issue Date:	<i>15/04/2015</i>
----------------	--------------------------	-------------	-------------------

Annex 25

210 Floor CE Mark & DOP



Declaration Of Performance (DOP)

210mm EPS Floor Elements, (210mm High x 600mm Wide).

DOP Ref:	<i>THDOP-00011a</i>	EU Directive:	<i>ISEN 13163:2012+A1:2015</i>
----------	---------------------	---------------	--------------------------------

Company Name:	<i>Thermohouse Ltd</i>
Place Of Manufacture:	<i>Coolcaslagh, Killarney, Co Kerry, Rep Of Ireland</i>

Product Description:	<i>210mm EPS Floor Elements, (210mm High x 600mm Wide).</i>
Intended Use:	<i>For installation as an internal non-load bearing thermal floor system, cut to customer specified lengths and used on private and commercial dwellings.</i>

Essential Characteristics:	Performance	Test Standard
<i>Declared Thermal Conductivity</i>	<i>0.030 W/mK</i>	<i>IS EN 12667</i>
<i>Declared Thermal Resistance</i>	<i>5.263 m²k/W</i>	<i>IS EN 12667</i>
<i>Compressive Strength at 10% Deformation</i>	<i>150 kN/m²</i>	<i>IS EN 826</i>
<i>EPS Density</i>	<i>Min 24kg/m³</i>	<i>IS EN 1602</i>
<i>Reaction to Fire</i>	<i>B1</i>	<i>DIN 4102</i>
<i>Water Vapour Diffusion Resistance Factor</i>	<i>μ = 51.4, sd = 2m</i>	<i>IS EN 12086</i>

Durability:	<i>This wall system when installed in accordance with the technical instructions as supplied by the manufacturer will achieve the values declared in this DOP.</i>
-------------	--------------------------------------------------------------------------------------------------------------------------------------------------------------------

Release of dangerous substances & emissions.	<i>MSDS information can be supplied on demand in the standard industrial format.</i>
----------------------------------------------	--------------------------------------------------------------------------------------

Signed on behalf of the manufacturer:		Full Name:	<i>Michael Cronin</i>
---------------------------------------	-------------------------------------------------------------------------------------	------------	-----------------------

Position Held:	<i>Managing Director</i>	Issue Date:	<i>15/04/2015</i>
----------------	--------------------------	-------------	-------------------

Annex 26

250 internal LB Walls CE Mark & DOP



Declaration Of Performance (DOP)

250mm EPS Wall Elements, Internal Load Bearing, (50mm Wall x 150mm Cavity x 50mm Wall).

DOP Ref:	<i>THDOP-00012</i>	EU Directive:	<i>ISEN 13163:2012+A1:2015</i>
----------	--------------------	---------------	--------------------------------

Company Name:	<i>Thermohouse Ltd</i>
Place Of Manufacture:	<i>Coolcaslagh, Killarney, Co Kerry, Rep Of Ireland</i>

Product Description:	<i>250mm EPS Wall Elements, (50mm Wall x 150mm Cavity x 50mm Wall).</i>
Intended Use:	<i>For installation as an internal load bearing thermal wall systems on private and commercial dwellings.</i>

Essential Characteristics:	Performance	Test Standard
<i>Declared Thermal Conductivity</i>	<i>0.030 W/mK</i>	<i>IS EN 12667</i>
<i>Declared Thermal Resistance</i>	<i>3.333 m2k/W</i>	<i>IS EN 12667</i>
<i>Compressive Strength at 10% Deformation</i>	<i>150 kN/m2</i>	<i>IS EN 826</i>
<i>EPS Density</i>	<i>Min 24kg/m3</i>	<i>IS EN 1602</i>
<i>Reaction to Fire</i>	<i>B1</i>	<i>DIN 4102</i>
<i>Water Vapour Diffusion Resistance Factor</i>	<i>μ = 51.4, sd = 2m</i>	<i>IS EN 12086</i>

Durability:	<i>This wall system when installed in accordance with the technical instructions as supplied by the manufacturer will achieve the values declared in this DOP.</i>
-------------	--------------------------------------------------------------------------------------------------------------------------------------------------------------------

Release of dangerous substances & emissions.	<i>MSDS information can be supplied on demand in the standard industrial format.</i>
----------------------------------------------	--------------------------------------------------------------------------------------

Signed on behalf of the manufacturer:		Full Name:	<i>Michael Cronin</i>
---------------------------------------	-------------------------------------------------------------------------------------	------------	-----------------------

Position Held:	<i>Managing Director</i>	Issue Date:	<i>15/04/2015</i>
----------------	--------------------------	-------------	-------------------

Annex 27

300 External Walls CE Mark & DOP



Declaration Of Performance (DOP)

300mm EPS Wall Elements, External Load Bearing, (100mm Ext x 150mm Cavity x 50mm Int).

DOP Ref:	<i>THDOP-00013</i>	EU Directive:	<i>ISEN 13163:2012+A1:2015</i>
-----------------	--------------------	----------------------	--------------------------------

Company Name:	<i>Thermohouse Ltd</i>
Place Of Manufacture:	<i>Coolcaslagh, Killarney, Co Kerry, Rep Of Ireland</i>

Product Description:	<i>300mm EPS Wall Elements, (100mm Ext x 150mm Cavity x 50mm Int).</i>
Intended Use:	<i>For installation as an external load bearing thermal wall systems on private and commercial dwellings.</i>

Essential Characteristics:	Performance	Test Standard
<i>Declared Thermal Conductivity</i>	<i>0.030 W/mK</i>	<i>IS EN 12667</i>
<i>Declared Thermal Resistance</i>	<i>5.000 m²k/W</i>	<i>IS EN 12667</i>
<i>Compressive Strength at 10% Deformation</i>	<i>150 kN/m²</i>	<i>IS EN 826</i>
<i>EPS Density</i>	<i>Min 24kg/m³</i>	<i>IS EN 1602</i>
<i>Reaction to Fire</i>	<i>B1</i>	<i>DIN 4102</i>
<i>Water Vapour Diffusion Resistance Factor</i>	<i>μ = 51.4, sd = 2m</i>	<i>IS EN 12086</i>

Durability:	<i>This wall system when installed in accordance with the technical instructions as supplied by the manufacturer will achieve the values declared in this DOP.</i>
--------------------	--------------------------------------------------------------------------------------------------------------------------------------------------------------------

Release of dangerous substances & emissions.	<i>MSDS information can be supplied on demand in the standard industrial format.</i>
---------------------------------------------------------	--------------------------------------------------------------------------------------

Signed on behalf of the manufacturer:		Full Name:	<i>Michael Cronin</i>
----------------------------------------------	-------------------------------------------------------------------------------------	-------------------	-----------------------

Position Held:	<i>Managing Director</i>	Issue Date:	<i>15/04/2015</i>
-----------------------	--------------------------	--------------------	-------------------

Annex 28

300 Internal LB Walls CE Mark & DOP



Declaration Of Performance (DOP)

300mm EPS Wall Elements, Internal Load Bearing, (50mm Wall x 200mm Cavity x 50mm Wall).

DOP Ref:	<i>THDOP-00014</i>	EU Directive:	<i>ISEN 13163:2012+A1:2015</i>
----------	--------------------	---------------	--------------------------------

Company Name:	<i>Thermohouse Ltd</i>
Place Of Manufacture:	<i>Coolcaslagh, Killarney, Co Kerry, Rep Of Ireland</i>

Product Description:	<i>300mm EPS Wall Elements, (50mm Wall x 200mm Cavity x 50mm Wall).</i>
Intended Use:	<i>For installation as an internal load bearing thermal wall systems on private and commercial dwellings.</i>

Essential Characteristics:	Performance	Test Standard
<i>Declared Thermal Conductivity</i>	<i>0.030 W/mK</i>	<i>IS EN 12667</i>
<i>Declared Thermal Resistance</i>	<i>5.000 m²k/W</i>	<i>IS EN 12667</i>
<i>Compressive Strength at 10% Deformation</i>	<i>150 kN/m²</i>	<i>IS EN 826</i>
<i>EPS Density</i>	<i>Min 24kg/m³</i>	<i>IS EN 1602</i>
<i>Reaction to Fire</i>	<i>B1</i>	<i>DIN 4102</i>
<i>Water Vapour Diffusion Resistance Factor</i>	<i>μ = 51.4, sd = 2m</i>	<i>IS EN 12086</i>

Durability:	<i>This wall system when installed in accordance with the technical instructions as supplied by the manufacturer will achieve the values declared in this DOP.</i>
-------------	--------------------------------------------------------------------------------------------------------------------------------------------------------------------

Release of dangerous substances & emissions.	<i>MSDS information can be supplied on demand in the standard industrial format.</i>
----------------------------------------------	--------------------------------------------------------------------------------------

Signed on behalf of the manufacturer:		Full Name:	<i>Michael Cronin</i>
---------------------------------------	-------------------------------------------------------------------------------------	------------	-----------------------

Position Held:	<i>Managing Director</i>	Issue Date:	<i>15/04/2015</i>
----------------	--------------------------	-------------	-------------------

Annex 29

350 External Walls CE Mark & DOP



Declaration Of Performance (DOP)

350mm EPS Wall Elements, External Load Bearing, (100mm Ext x 200mm Cavity x 50mm Int).

DOP Ref:	<i>THDOP-00015</i>	EU Directive:	<i>ISEN 13163:2012+A1:2015</i>
----------	--------------------	---------------	--------------------------------

Company Name:	<i>Thermohouse Ltd</i>
Place Of Manufacture:	<i>Coolcaslagh, Killarney, Co Kerry, Rep Of Ireland</i>

Product Description:	<i>350mm EPS Wall Elements, (100mm Ext x 200mm Cavity x 50mm Int).</i>
Intended Use:	<i>For installation as an external load bearing thermal wall systems on private and commercial dwellings.</i>

Essential Characteristics:	Performance	Test Standard
<i>Declared Thermal Conductivity</i>	<i>0.030 W/mK</i>	<i>IS EN 12667</i>
<i>Declared Thermal Resistance</i>	<i>5.000 m2k/W</i>	<i>IS EN 12667</i>
<i>Compressive Strength at 10% Deformation</i>	<i>150 kN/m2</i>	<i>IS EN 826</i>
<i>EPS Density</i>	<i>Min 24kg/m3</i>	<i>IS EN 1602</i>
<i>Reaction to Fire</i>	<i>B1</i>	<i>DIN 4102</i>
<i>Water Vapour Diffusion Resistance Factor</i>	<i>μ = 51.4, sd = 2m</i>	<i>IS EN 12086</i>

Durability:	<i>This wall system when installed in accordance with the technical instructions as supplied by the manufacturer will achieve the values declared in this DOP.</i>
-------------	--------------------------------------------------------------------------------------------------------------------------------------------------------------------

Release of dangerous substances & emissions.	<i>MSDS information can be supplied on demand in the standard industrial format.</i>
----------------------------------------------	--------------------------------------------------------------------------------------

Signed on behalf of the manufacturer:		Full Name:	<i>Michael Cronin</i>
---------------------------------------	--	------------	-----------------------

Position Held:	<i>Managing Director</i>	Issue Date:	<i>15/04/2015</i>
----------------	--------------------------	-------------	-------------------

Annex 30

Pre-pour Checklist

Date: _____ **Supervisor:** _____

Job Reference: _____

Prior to commencing concrete placement within the Thermohouse insulated forms, ensure that each item on the following checklist is checked off:

- Is the string line correctly positioned around the entire top perimeter?
- Are the walls straight and plumb, without any outward leaning?
- Have additional form supports been added to all corners?
- Have additional form supports been added to all window and door openings?
- Are all fastening screws securely fixed to the blocks?
- Is the alignment system firmly attached to the floor?
- Have all the necessary handrails and toe boards been installed in compliance with current building regulations?
- Are all lintels supporting doors and windows in place?
- Is all horizontal and vertical reinforcement correctly positioned?
- Is lintel reinforcement properly installed?
- Are all floor embedment's correctly positioned?
- Has the cavity wall been inspected and cleared of any foreign material?
- Has the appropriate concrete pump (with a maximum size of 75/100mm) been ordered?
- Have the correct concrete mix, volume, and slump classification been ordered?
- Is a concrete vibrator (with a maximum size of 37mm) available on-site and in working condition?

NOTE: If this checklist is not fully completed, DO NOT PROCEED with concrete pouring.

The pivotal stage of a successful Thermohouse project lies in concrete placement. For optimum results, it's crucial to have an adequate number of workers present. Ensure that a sufficient team is available during the pour to manage safe placement, consolidate the concrete, maintain alignment, and perform cleanup. Ideally, concrete placement should involve at least a four-person team, with one person on the nozzle, two on the poker, and another coordinating between the nozzle and pump. To ensure efficiency, consider having a crew of 5-6 members available during concrete placement.

Ensure the straightness of walls by positioning a straight line at the top course, set off 20mm from the wall, using spacers at each corner. If needed, adjust the turnbuckles to maintain wall straightness during placement.

Concrete must be supplied by an approved concrete supplier.

**The minimum compressive concrete strength for walls should be C25/30.
The concrete's workability should fall within S3 (Slump 100mm to 150mm).**

It's important to note that the specific requirements may vary from site to site and should always be confirmed by the Project Engineer. **The maximum aggregate size to be used within the Thermohouse forms is 10mm.**

Annex 31

Post-pour Checklist

Date: _____ Supervisor: _____

Job Reference: _____

After the concrete has been placed within the Thermohouse forms, ensure that each item on the following checklist is checked off:

- Is Concrete Consolidation Completed?
- Are Walls Aligned with String Line?
- Have All Anchors and Embedments Been Installed?
- Has Spilled Concrete Been Properly Removed?
- Have Final Checks for Straightness and Plumbness Been Performed?
- Are Window Sill and Wall Plate Seats Leveled and Finished?
- Are ICF Locking Lugs Cleaned from Concrete Spills to Facilitate Proper Installation of the Next Course?

Annex 32

Invoice & Delivery Information

INVOICE & DELIVERY INFORMATION FORM

Invoice Name:	
Full Invoice Address:	
Contact Phone Number:	
Contact email address for invoicing:	
Full site Address:	
Postcode / Eircode for Site:	
Site Contact for deliveries:	
Site Contact Phone Number:	
Confirmation that the delivery can be made by a 45ft Articulated truck with a height of 15.5ft: PLEASE NOTE THAT ANY LOW HANGING CABLES HAVE THE POTENTIAL TO HALT DELIVERY AND TRUCK MAY HAVE TO BE UNLOADED AT THIS POINT. ANY DELIVERIES THAT REQUIRE A SMALLER TRUCK WILL OCCUR ADDITIONAL COSTS BASED ON LOCATION.	
Any additional information relevant to delivery:	
I confirm that I have read and understood the delivery, handling and storage guide supplied	

THERMOHOUSE RESERVES THE RIGHT TO REFUSE DELIVERY IF THE TRUCK CANNOT MAKE SAFE ACCESS TO THE DELIVERY SITE

Annex 33

Technical Details Register

Manual Diagram Ref	Description	TH Ref Code
G1	Design Guidelines	
F1	Re-inforcement + INT & Ext Tanking Detail	
F2	Basement Raft Foundation Detail	TH-002
F3	Strip Foundation Detail	TH-001
F4	Raft Foundation Detail	TH-002a
F5	Raft Foundation with Perimeter Insulation	
F6	Basement wall Corner Assembly	
W1	End Block Corner Assembly - Standard Corner	TH-023
W2	300mm Party Wall to External Wall Detail with Brick Skin	
W3	Firestopping on Party Wall Detail	TH-017
W4	300mm Party Wall to External Wall Detail (ICF)	
W5	Internal Load Bearing Wall Abutting to External Wall	TH-024
W6	Party Wall Abutting to External Wall	TH-026
W7	Internal Block Wall Abutting External ICF Wall	TH-025
W8	Typical Horizontal Fire Stop at Floor Level Detail	TH-017b
W9	Abutment to Existing Build	
W10	PPC Aluminium Window Cill	TH-011
W11	(Steel) Thermowall Fixing Plates	TH-017L
W12	Re-inforcing Steel Design	TH-016
W13	Ext Wall Build up above 350mm Basement Block	THF-003b
W14	Internal Load Bearing Wall Abutting to External ICF Wall	TH-025b
W15	3.0m Wall Support & Scaffold Support	
W15b	3.0m Corner Wall Support	
W16	End Block Corner Assemble - Inverted Corner	
W17	Concrete Window Cill	TH-010
W18	Section Through Door Opening	TH-014
W19	Window Head	
W20	Window Head	TH-012 Fig 19
W21	(Plan View) Rebate Block at Window/Door Opening	TH-013 fig 3
W21	Window Reveal Detail	TH-013 fig 10
W22	Reveal Section - Flush Mounted Window	
W23	Thermowall Finished with Stone or Brick	TH-028c
W24	Thermowall Finished with Brick Slip	TH-028d
W25	Thermowall Finished with Cadding	TH-018e
W26	90 Deg Internal Corner Assembly	
W27	Connecting Traditional Block Walls to ICF Junctions	
W28	Wallboard fixed to Thermowall	
W29	Wallboard fixed to Batten on Thermowall	

W30	Firestop Detail	
W31	Wall Plate for Thermorooft Detail	
TF1	Suspended G/F Thermofloor Detail (U-Value 0.16)	THF-002
TF2	Placement of TH21 External Leaf with Floor Panel	
TF3	Edge Support to TH21 at Floor Edge (Photo)	
TF4	Intermediate Thermofloor Build Up	
TF5	Intermediate Thermofloor	
TF6	Thermofloor Propping Support	
TF7	Thermofloor Propping Support (Photo)	
TF8	Acrow Placements - Step 1	THF-004
TF9	Acrow Placements - Step 2	THF-005
TF10	Acrow Placements - Step 3	THF-006
TF11	Concrete Area Coverage	
TF12a	Cantilever Floor	
TF12b	In-situ Floor Beam	
TF13	Pre-Cast Floor on External Wall	TH-003
TF14	Pre-Cast Floor on Internal Wall	TH-005
TF15	Block & Beam on Thermowall	TH-001c
TF16	Block & Beam on Brick Wall	TH-001d
TF17	Metal Deck Floor	TH-006
TF18a	Timber Joist Fixing - Option 1	TH-007
TF18b	Timber Joist Fixing - Option 2	
TF18c	Timber Joist Fixing - Option 3	
TF18d	Timber Joist Fixing - Option 4	TH-007
TF19	Metal Ledger System Detail	TH-008
TF20a	Thermofloor 210mm Flat Roof (Open Edge)	THF-010
TF20b	Thermofloor 210mm Flat Roof (Parapet)	THF-010
TF20c	Thermofloor Flat Roof Section	THF-010
TF21	160mm Suspended Floor Build Up	
TF22	210mm Suspended Floor Build Up	
TR1	Thermorooft Element	THR-001
TR2	Thermorooft Element Dimensions	THR-002
TR3	Beval Cut Detail	THR-003
TR4	Thermorooft to Thermowall	
TR5	Thermorooft to Thermowall 450mm	THR-008a
TR6	Timber Cut or Truss Roof to Thermowall	
TR7	Thermorooft to Brick/Block Wall	THR-008c
TR8	Thermorooft Ridge on Steel Detail	THR-010a
TR9	Thermorooft Fixing Detail	THR-010a
TR10	Thermorooft on Timber Ridge Detail	THR-010b
TR11	Thermorooft Valley Detail	
TR12	Thermorooft Purlin (Timber on Steel Beam)	THR-004a
TR13	Thermorooft Purlin (Timber on Steel Beam) Through section	THR-004a
TR14	Thermorooft Timber Purlin	THR-0043b
TR15	Thermorooft Timber Purlin (through Section)	THR-0043b
TR16	Thermorooft Concealed Purlin	
TR17	Thermorooft & Thermowall Party Wall Firestop	THR-017

TR18	Thermorooft Airtightness Sealing	
TR19	Thermorooft Sealing Tape	THR-006
TR20	Thermorooft Rooflight Detail	THR-13a
TR21	Dormer Windows	THR-018
TR22	Roof Batten Fixing	THR-005
TR23	Roof Batten & Underlay Fixing	THR-007
TR24	Chimney Stack Cross Section	THR-011
TR25	Angled End Thermorooft Detail	THR-008
TR26	Straight End Thermorooft Detail	
TR27	Wallplate Shoe Overhang Section	THR-008b1
TR28	Flush Facia	THR-008c
TR29a	Gable End / Timber Ladder (Option A)	Photo
TR29b	Gable End / Timber Ladder (Option B)	THR-015a
TR29c	Gable End / Timber Ladder (Option C)	THR-015b
TR31	Fabrication of Collar Ladder	
TR32	Lead Flashing	THR-012
TR33	Plasterboard Fixing on Batten to Thermorooft	THR-009a
TR34	Rendered Finish to Thermorooft	THR-009b
TR35	Zinc Type Roof Finish	THR-022
TR36	Thermorooft Flat Roof with Overhang	THR-016
TR37	Thermorooft Flat Roof with Parapet	THR-016a
TR38	Thermorooft Lean-to Roof	THR-014
TB1	30mm Free Flow Thermoscreed	
TB2	75mm Free Flow Concrete Screed	

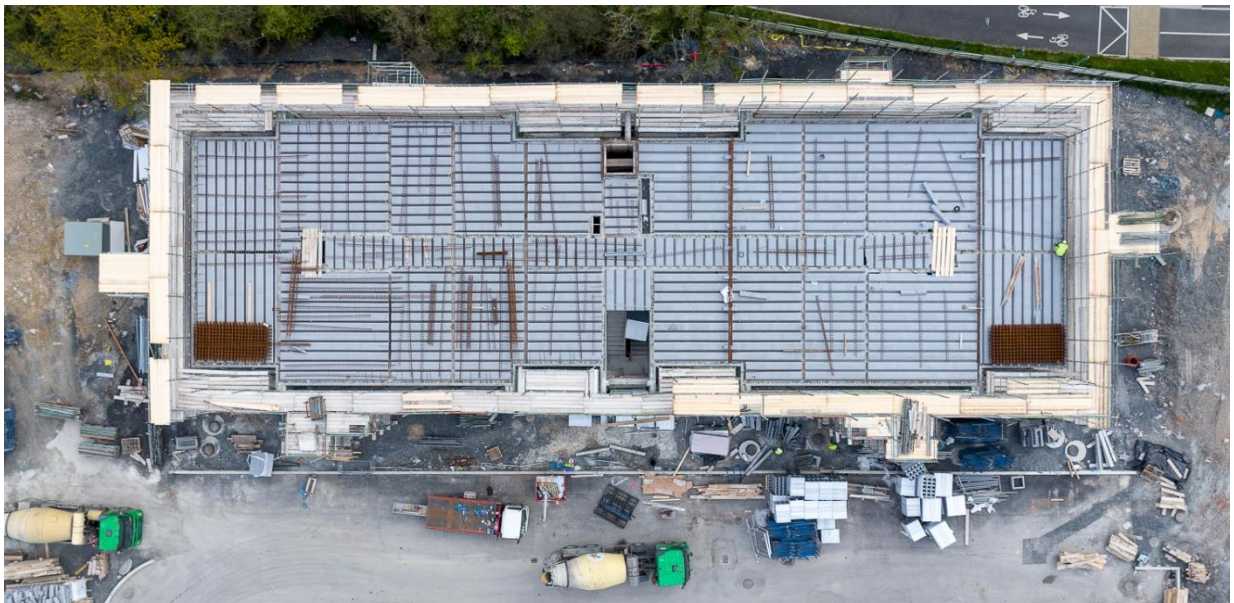
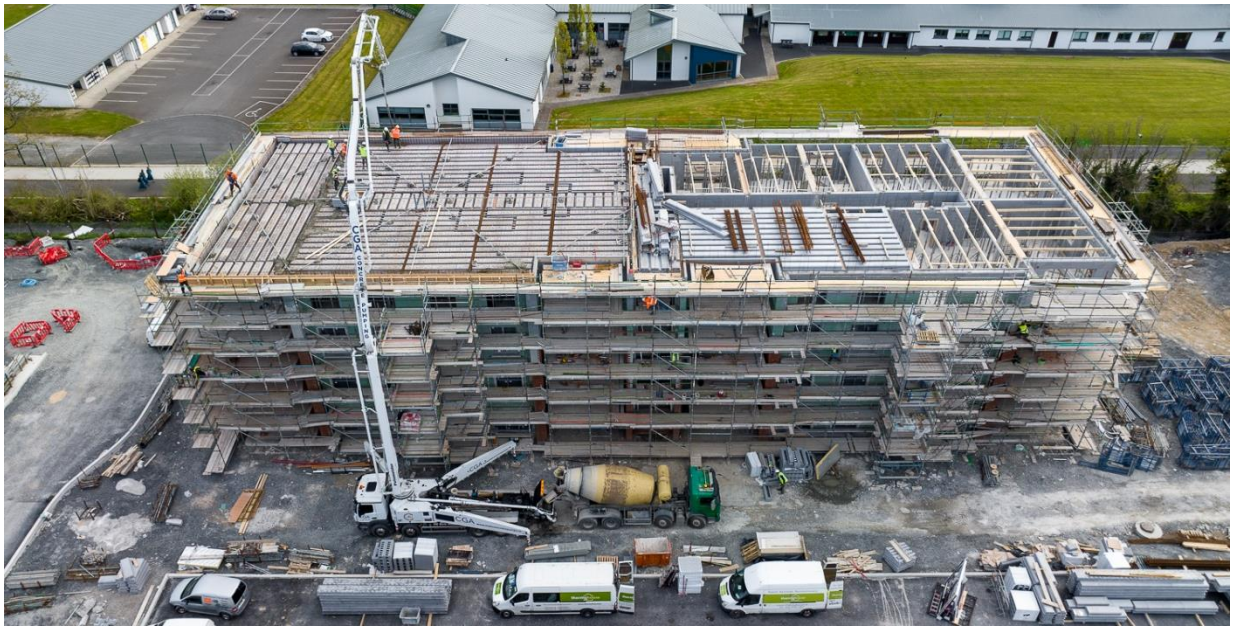









the complete low energy building system

Thermohouse Ireland Ltd

Coolcaslagh, Killarney
V93 XK82
Co. Kerry

Tel: +353 (0) 64 6631307
Fax: +353 (0) 64 6632394

Email: info@thermohouse.ie
Website: www.thermohouse.ie

Thermohouse UK Ltd

Unit 2, White Hart Road
Slough, Berkshire
SL1 2SF

Tel: +44 (0) 203 771 7426

Email: sales@Thermohouse.co.uk
Website: www.thermohouse.co.uk